

Serial Numbers 110001P & Up

OPERATION MANUAL



The Challenge Machinery Company
6125 Norton Center Drive
Norton Shores, MI. 49441

challengemachinery.com

TITAN 200BC

MANUAL BACKGAUGE PAPER CUTTING MACHINE

Sold and Serviced by

F.200BC-O
February 2011

1.0 Introduction

THIS MANUAL is designed to help you get the most from your Challenge equipment. Keep this manual in a safe, convenient place for quick reference by operators and service personnel.



CAUTION SAFETY ALERT! This symbol means **CAUTION: Personal safety instructions!** Pay special attention to the instructions in bold type. Personal injury may result if the precautions are not read and followed.

READ THIS MANUAL BEFORE OPERATING! Follow precautions and instructions given and you should have years of trouble-free operation. If after reading the manual questions still remain, contact your Authorized Challenge Dealer.

FOR PARTS AND SERVICE contact the Authorized Challenge Dealer from whom you purchased your machine. Use the illustrations and parts lists at the back of this manual to identify the correct parts needed. Always give the **SERIAL NUMBER** and **MODEL** of your machine to insure the correct parts are sent as soon as possible.

Take a few minutes right now to **RECORD YOUR MACHINE SERIAL NUMBER** in the space provided on the front cover of this manual. Also be sure to fill out the warranty card accompanying your machine and return it **DIRECTLY TO CHALLENGE**.

If you bought a used machine, it is important to have the following information on record at Challenge. Copy this page, fill in the information and send it care of The Challenge Service Department, 6125 Norton Center Drive, Norton Shores MI. 49441.

CHALLENGE MODEL Titan 200BC	SERIAL NUMBER	
ATTN	COMPANY	
ADDRESS		
CITY	STATE/PROVINCE	ZIP
PHONE	DATE INSTALLED	
DEALER NAME & CITY		

* WARRANTY INFORMATION *

It is very important that you read and understand the conditions outlined in the *Warranty Information Sheet* attached to the outside of the shipping container of your machine.

The *Warranty Information Sheet* must be filled out completely and returned to THE CHALLENGE MACHINERY COMPANY in order for the warranty to be issued for this machine.

TABLE OF CONTENTS

1.0 Introduction	2
2.0 Safety	4
2.1 Precautions	4
2.2 Power Lockout Procedure	4
2.3 Warning Label Definitions	5
3.0 Packing List	7
4.0 Specifications	8
5.0 Installation & Setup	9
5.1 Inspecting Shipment	9
5.2 Floor Plan (Standard Table)	9
5.3 Floor Plan (Short Table Option)	10
5.4 Uncrating	11
5.5 Cleaning	12
5.6 Fitting Through Narrow Door (Standard Table)	12
5.6.1 Removing the Table	12
5.6.2 Reattaching the Table	13
5.7 Fitting Through a Narrow Door (Short Table Option)	13
5.8 Hydraulic System Check	14
5.9 False Clamp Plate (Optional)	15
5.10 Power Hook-Up	15
6.0 Operation	16
6.1 Console Controls	16
6.2 Making a Cut	16
6.3 Jogging Aid	17
6.4 Backgauge Control	17
7.0 Knife Installation/Changing	18
7.1 Knife Removal	18
7.2 Knife Installation	20
7.3 Knife Care Tips	21
7.3.1 Knife Blade Life	21
7.3.2 Cutting Stick	22
7.3.3 Bevel Angle	22
7.3.4 Helpful Suggestions	22
7.3.5 Knife Care	22
8.0 Lubrication	24
9.0 Safety Systems Test	27

2.0 Safety

2.1 Precautions

- This machine is designed for one-person operation. Never operate the machine with more than one person.
- Safe use of this machine is the responsibility of the operator. Use good judgment and common sense when working with and around this machine.
- Read and understand all instructions thoroughly before using the machine. If questions remain, contact the dealer from which you purchased this machine. Failure to understand the operating instructions may result in personal injury.
- Only trained and authorized people should operate this machine.
- **DO NOT ALTER SAFETY GUARDS OR DEVICES.** They are for your protection. Severe personal injury may result.
- **Disconnect power** before cleaning or performing maintenance. See Section 2.2 Power Lockout Procedure.
- Observe all caution labels on this machine.
- Be sure the cutter is properly grounded.
- Be sure there is sufficient power to operate the cutter properly.
- Observe all caution plates mounted on this cutter.
- Keep foreign objects off table and away from cutter blade.
- **BE EXTREMELY CAREFUL** when handling and changing the cutter knife. Severe lacerations or dismemberment could result from careless handling procedures.
- Keep the floor around the cutter free of trim, debris, oil and grease.
- When replacing hydraulic parts, loosen the connections slowly to release pressure. Never loosen connections with the machine running.
- If the cutter sounds or operates unusually, switch it off and consult the troubleshooting section of this manual. If the problem cannot be corrected, have it checked by a qualified service person.
- **CRUSH HAZARD**, keep hand and fingers from under the clamp when clamping paper. Use Jogging Aid to load paper, and use the backgauge to push paper out before unloading. **DO NOT REACH UNDER THE KNIFE AND CLAMP AREA!**

2.2 Power Lockout Procedure

For maximum safety while making adjustments or repairs to your machine, be sure to disconnect power to the machine. Disconnect the power plug from its socket

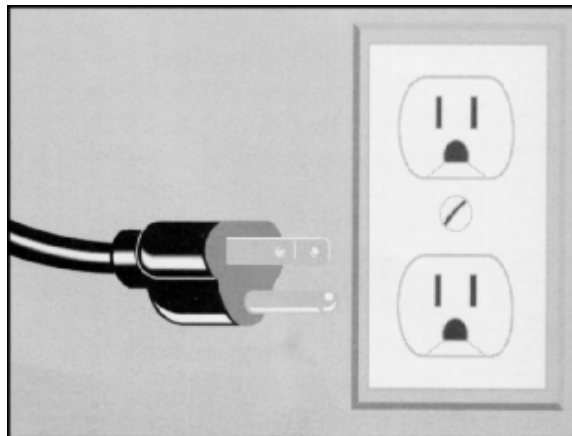

Figure 1 - Main Power Disconnect

2.3 Warning Label Definitions

The following warning labels are found at various locations on your machine. Read and understand the meaning of each symbol. If a label is lost from the machine, it should be replaced.



HAZARDOUS AREA

Disconnect power before cleaning, servicing, or making adjustments not requiring power. Do not alter safety guards or devices; they are for your protection. Replace all guards. Do not operate with any guards removed.



SHOCK HAZARD

Disconnect power before removing cover. Replace cover before operation.



SHOCK HAZARD

Disconnect power before removing cover. Replace cover before operation.



SINGLE OPERATOR

Do not operate with more than one person.

!OJO!

! CAUTION

This Este simbolo de alerta de seguridad significa ¡ OJO ! - INSTRUCCIONES DE SEGURIDAD PERSONAL. Lea las instrucciones porque se refieren a su seguridad personal. Fall de obedecer las instrucciones que siguen podria resultar en lesiones corporales.

- Esta maquina, junto con sus mecanismos de seguridad, esta disenada para ser manejada por
- **UNA SOLA PERSONA** a la vez. Jamas debe ser manejada por mas de una persona al mismo tiempo.
- La seguridad es la responsabilidad del operario que usa esta maquina.
- **LEA DETENIDAMENTE** el manual de instrucciones y las **PRECAUCIONES DE SEGURIDAD** antes de poner a funcionar la cortadora. Pidale a su supervisor una copia.
- El manejo de la guillotina debe estar exclusivamente a cargo de personal entrenado y autorizado para ello.
- **NO MODIFIQUE LOS MECANISMOS DE SEGURIDAD**, estan ahi para su proteccion no deben ni modificarse ni quitarse.
- **DESCONECTE LA CORRIENTE ELECTRICA** antes de proceder a hacerle servicio de limpieza, engrasar, o de hacer ajustes que no requieren corriente. Trabe el interruptor en la posicion **OFF** (apagado); vea "Procedimiento para cortar la corriente electrica" al pie de esta pagina.
- Eche llave a la guillotina y quite la llave cuando la maquina no esta en operacion; vea "Corriente electrica".
- Asegurese de que la guillotina este debidamente a tierra. Vea "Conexion de la fuerza electrica".
- Verifique el voltaje y asegurese de que este sea suficiente para el debido funcionamiento de la guillotina.
- Preste atencion a todas las placas con advertencias instaladas en esta guillotina.
- No permita que objetos estranos esten en la mesa o cerca de la cuchilla cortadora.
- **TENGA SUMO CUIDADO** al tocar y cambiar la cuchilla. Heridas severas y hasta desmembramiento pueden resultar del manejo sin cuidado o negligente.
- El suelo alrededor de la guillotina debe mantenerse despejado y libre de recortes, desperdicios, aceite y grasa.
- Al haber la necesidad de reemplazar partes hidraulicas, afloje todas las conexiones poco a poco para dejar escapar la presion. Jamas debe aflojarse conexiones mientras la maquina este andando.
- Si la guillotina empezara a sonar o trabajar diferentemente a lo acostumbrado, desconectela y consulte la seccion "Troubleshooting" (Reparador) de este manual. Si no es posible corregir el problema, llame a su servicio autorizado para que le examinen la maquina.
- **PELIGRO DE MACHUQUE** - Mantenga manos y dedos fuera de la agarradera mientras sujeta el papel. Use el calibrador trasero y su rueda de mano para empujar el papel cortado. **NO PONGA SUS MANOS BAJOLA CUCHILLA O AREA DE LA AGARRADERA.**
- **NO OPERE SIN LAS GUARDAS PROTECTORAS!**

¡ OJO ! PRECAUCION - Como proceder para desconectar la corriente electrica.

Para maxima seguridad durante ajustes y reparaciones de su maquina, verifique bien que el interruptor principal de control de corriente al cual la maquina esta conectada, este desconectado. El interruptor deba ser puesto en la posicion "OFF" (desconectado) y se debe poner un candado en la anilla. La llave del candado debe ser guardada por la persona que estara efectuando los trabajos de servicio o de reparacion en la guillotina.

Desconecte la corriente electrica antes de proceder a hacer cualquier ajuste o reparacion o de efectuar el engrase en cualquier maquina.

3.0 Packing List



Part No.	Description	Qty.
A-10034	Knife	1
4166	Cutting Stick (in addition to one installed in machine)	1
F.200BC-O	Operation Manual	1
70025	Jogging Aid	1
	Tool Kit	
H-6918-608	Knife Bolts, 3/8 – 16 x 1"	4
8815	Knife Washers, Special	4
5064	Cutting Stick Puller	1
43108	Knife Lifter Assembly	1
W-130	3/16" Allen Wrench	1
W-137	5/32" Allen Wrench	1
W-164	5/16" Hex 'T' Wrench	1
W-170	9/16 x 1/2" Wrench	1

Optional Items

Part No.	Description	Qty.
AA-10061	False Clamp Plate	
5-7-M361	Backgauge Book Guides	
4166	Cutting Stick	
A-10034-1	High Speed Steel Knife	
K-70027	Foot Pedal Kit	

4.0 Specifications

Description	Inch Units	Metric Units
Cutting Width	20"	508 mm
Minimum Cut*	1/2"	13 mm
Clamp Opening	3 1/4"	83 mm
Table Space		
Front:	16"	406 mm
Back:	20"	508 mm
Dimensions		
Table Height	36"	91 cm
Overall Height	52-1/2"	133 cm
Overall Length**	52"	132 cm
Overall Width	36"	91 cm
Approx. Net Weight	755 lbs	342 kg
Approx. Shipping Weight	950 lbs	431 kg
Electrical		
120 Volts 60 HZ. 12 Amps, Service Size 15 Amps Receptacle NEMA 5-15R		
Optional		
208/230 Volts, 12 Amps, 1 Phase, 50/60 Hz, AC. Service size 15 Amps Recommended Receptacle: 208-230 Volt, NEMA 6-15R or NEMA 6-20R		
Sound Emission		
A-weighted sound pressure level measured in an enclosed room at operator level (6 feet/183 cm): Machine cutting a full lift of paper: 77 dB		

*With false clamp plate attached, minimum cut is 1-7/8" (48 mm).

**With table and front guard removed, can be fit through a 28" (71 cm) door opening.

Challenge reserves the right to make changes to any product or specification without notice and without incurring responsibility to existing units.

5.0 Installation & Setup

5.1 Inspecting Shipment

This machine has been carefully packed to prevent damage during shipment. However, claims for damage or loss are the responsibility of the recipient. Inspect all shipments as soon as they are received. If there is any noticeable damage, note it on the freight bill. Visual and/or hidden damage must be reported to the claims department of the carrier within 15 days. Contact your dealer if you need any assistance. Check the contents of the box against the packing list on page 7. Make sure there are no missing items.

5.2 Floor Plan (Standard Table)

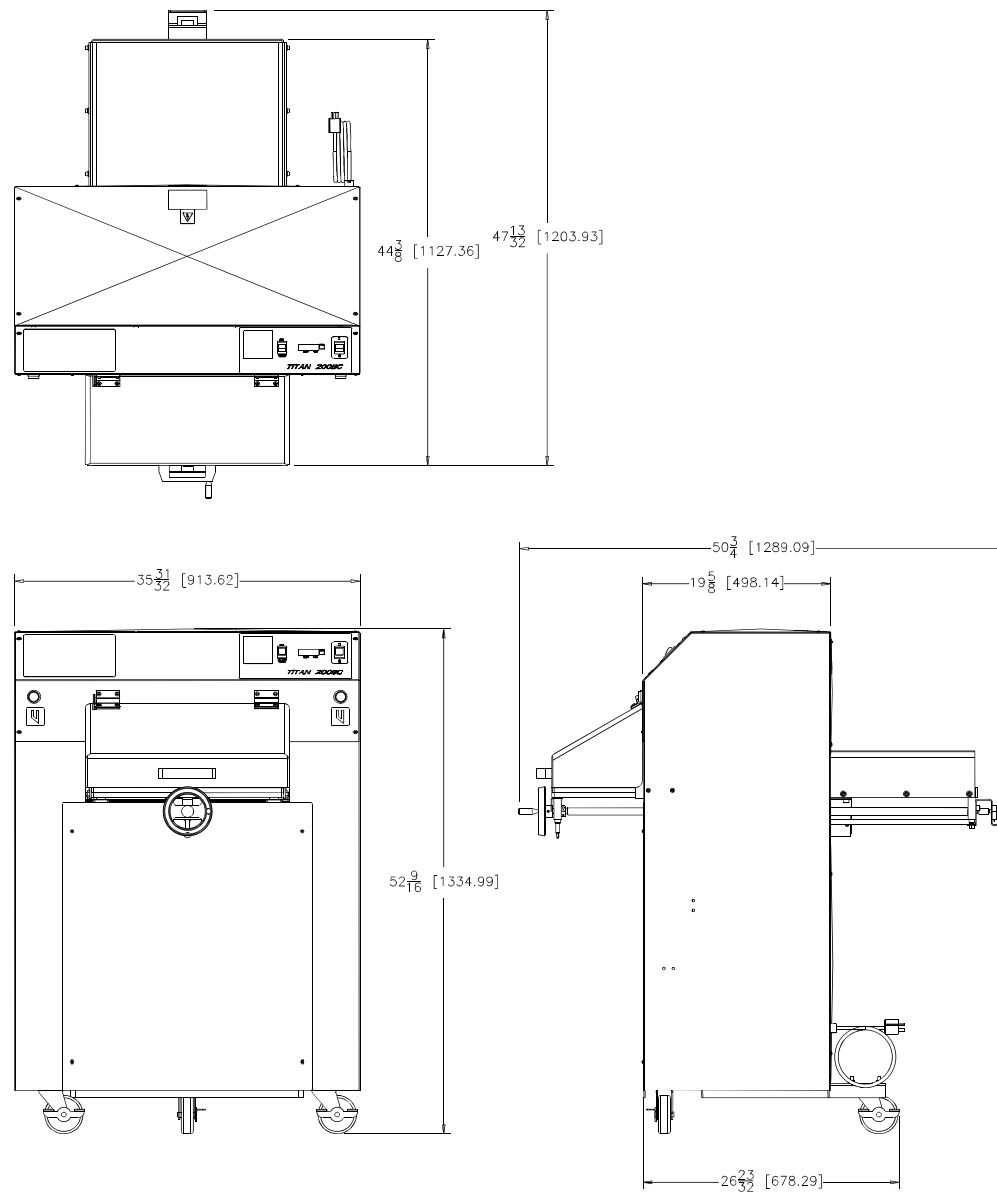

Figure 2

5.3 Floor Plan (Short Table Option)

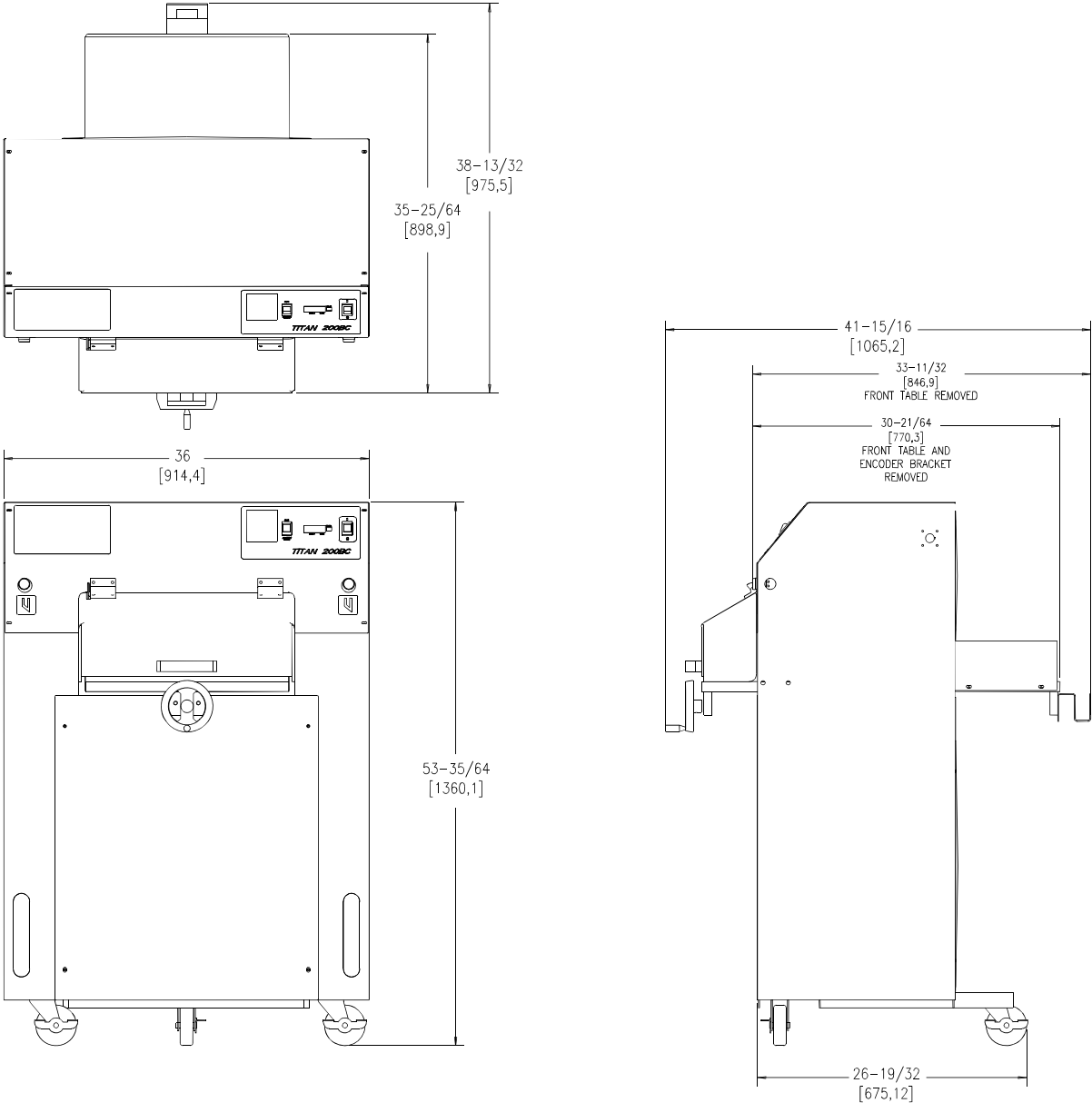

Figure 3

5.4 Uncrating

The Titan 200BC weighs approximately 755 lbs (342kg). DO NOT risk personal injury or damage by attempting to move machinery with makeshift equipment or inadequate manpower. This machine is shipped on a wooden skid and enclosed in a protective, corrugated top. The skid is designed to allow the machine to be rolled off without any special lifting equipment. The machine is held in place by two, 2x4 braces lag bolted to the skid. All accessories are shipped inside of the machine.

Remove the carton by removing the nails or staples holding it to the skid and lift it straight up over the cutter. If you don't have the ceiling clearance to do this, carefully slit the carton down the side and then unwrap it from around the cutter.

Remove all lag screws from the skid. Remove the lower front cover of the Titan 200BC and remove the two lag screws in the base. Remove the accessories.

Using the rear bumper board, pry one side of the machine up, and slide out the top layer of the support riser (Figure 4). Do the same on the other side.



Figure 4 (Similar Model)

Use the flat board provided as a ramp and position as shown in (Figure 5 on page 12). Hold the ramp in place with the nails provided. Make sure the casters are not locked and very carefully roll the machine down the ramp. The cutter may now be rolled into position.



Figure 5 (Similar Model)

5.5 Cleaning

After unpacking, wipe down all machine panels and clean the table surface.

5.6 Fitting Through Narrow Door (Standard Table)

The Titan 200BC cutter will not fit through an opening less than 36" (91 cm) without the table being removed. With the table removed, it will fit through a 35" (89 cm) opening. With the table and front guard, it will fit through a 23" (59 cm) opening.

5.6.1 Removing the Table

Make sure the knife and clamp are in the up position. If they are not, read the Power Hookup section (page 15) to connect power to the machine. Switch on the power using switch highlighted with yellow, close the front guard, and press the cut buttons. This will send the knife and clamp up.

Switch off the machine and unplug the power cord.

Disconnect the encoder cable at the encoder. Remove the two, rear panels, the lower front cover, and the backgauge cover. Remove the hand wheel and front pillow block. Replace the front pillow block with the Table Out Lead Screw Bracket, 70007.

Remove the nylon tyrraps that are attached to the bottom of the table. The encoder wires should now be free from the table.

From the rear of the machine, disconnect the preset board assembly and leave the cable inside the machine.

Remove the cut stick from the table using the cut stick removal tool. Locate the two taper pins in the cut stick slot. These must be tapped out from under the base through the table slot and removed. Then remove the four screws that mount the table to the base. NOTE: The table assembly is very heavy and requires two people to remove. Using access holes in the side of the machine, remove the two front side guides. Pull the table out from the back of the machine. Locate the four round spacers that were between the table and the base. They are needed for reassembly.

Remove (4) screws that mount the shield to its hinges. Save the (2) steel brackets for reassembly.

5.6.2 Reattaching the Table

Set the table in position. Lift the table from the front and set the two front spacers in place. Insert the front two socket head screws, but do not tighten. Lift the table from the rear and set the two rear spacers in place. Start the rear two socket head screws. Reinsert the two taper pins, and tap into position so they are below bottom of the slot. Tighten all four screws. Attach the right and left side guides. Reconnect the preset and encoder wires, and all other items that were removed. After the table is installed, reassemble the front pillow block and hand wheel. The backgauge squareness and accuracy will have to be reset. See the Accuracy Adjust section and the Squaring the Backgauge section in the Technical Manual. Reinstall the shield and verify proper operation of the interlock switch. Readjust the cam bracket on the left hinge as necessary.

5.7 Fitting Through a Narrow Door (Short Table Option)

The machine has been shipped with the front table and tilt shield removed. Reassemble the machine using the following instructions. The machine will roll through a 33-5/8" opening sideways. If the encoder bracket is removed as well it will roll through a 30-1/2" opening.

1. Roll the machine into place and unpack the parts to be assembled.
2. Remove the blocking from the backgauge and slide the backgauge to the rear of the machine.
3. Remove the lower front cover, and install the front table. Use (2) 3/8-16 X 1" socket head cap screws to attach the table to the base casting.



Figure 6

4. Use (2) 3/8-16 X 3/4" socket head cap screws and (2) 3/8 lock washers to fasten the front table to the main table.

5. Install the lead screw. From the front of the machine, fish the lead screw under the table, through the base casting, and into the backgauge carrier. Turn the screw in the acme nut that is inside the backgauge carrier. Turn the screw until the end passes through the rear pillow block and the holes in the front pillow block line up with the holes in the front table. Use (2) 3/8-16 X 2-3/4" socket head cap screws to fasten the front pillow block to the front table.
6. At the rear of the machine, slide the flexible encoder coupling over the pin at the end of the lead screw such that half of it over the pin and half of it is over encoder shaft.
7. Use (4) 1/4-20 button head screws to fasten the tilt shield to the hinges on the stand above the front table. The shield is placed under the hinges and the (2) steel mounting brackets are placed under the shield as shown in the following figure.

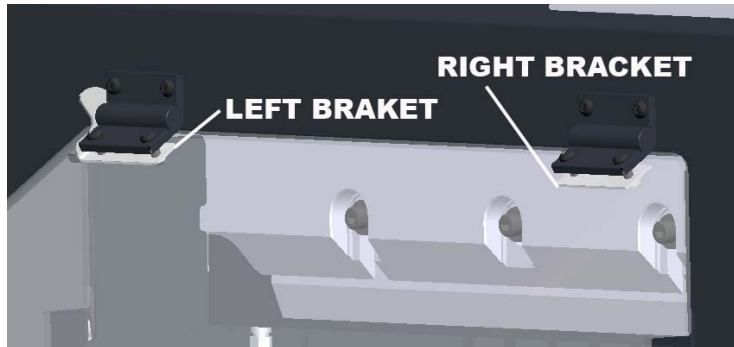

Figure 7

8. Go to section 8.0 on page 24 and perform the Safety System Tests after the remainder of the installation is complete. If the machine fails the test, readjust the left hand interlock switch bracket until the machine passes the test.

5.8 Hydraulic System Check

The cutting/clamping mechanism of the Titan 200BC is powered by a hydraulic system consisting of an electric motor coupled directly to a hydraulic pump.

The hydraulic reservoir holds 1 gallon (3,8 liters) of hydraulic fluid. It is filled with ISO VG 100 hydraulic fluid at the factory but should be checked before operation. Remove the lower rear panel cover and unscrew the cap on top of the tank (Figure 8). Fluid level should be at 1/8" (3mm) from the end of the dip stick (check with dip stick cap screwed in). Add fluid if necessary but avoid overfilling. Replace the rear panel when finished.

The hydraulic fluid should be checked weekly and changed **AT LEAST ONCE-A-YEAR** or after every 1,000 hours of operation.



Figure 8

5.9 False Clamp Plate (Optional)

To prevent marking on pressure sensitive jobs, a false clamp plate is available as an optional item for your machine. This plate attaches to the bottom of the clamp. It is secured with wing nuts on studs that pass through the top of the clamp.

To install:

1. Make sure the knife and clamp is in the up position. If they are not, switch on the power, close the front guard, and press the cut buttons. This will send the knife and clamp up.
2. Switch power off and disconnect the power cord.
3. Remove the rear cover and slide the false clamp plate under the knife and clamp (Figure 9) and slide the plate up into position with the locator pins toward the front of the machine. The locator pins insert into holes in the bottom front of the clamp. **CAUTION! Do not rub your fingers up the front side of the clamp. You may cut your fingertips.**
4. Hold the plate in position and secure with the wing nuts provided.

NOTE: The minimum cut with the false clamp plate attached is 1-7/8"

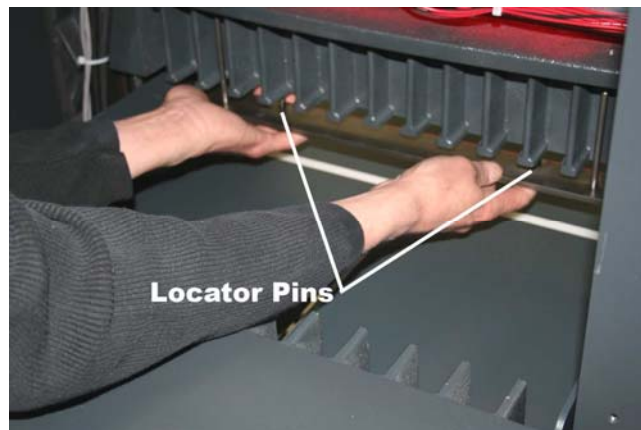

Figure 9

5.10 Power Hook-Up

⚠ CAUTION **SHOCK HAZARD! NEVER CUT THE GROUND TERMINAL** from a three-prong plug to fit a two-prong socket. Possible shock could cause personal injury or death. Hire a qualified electrician to provide a power source that meets electrical requirements and all local electrical codes.

It is the customer's responsibility to provide a properly grounded receptacle that meets the power requirements specified on the nameplate of this machine, as well as all local electrical codes. Have a qualified electrician install one if your location is not so equipped.

Connect the power cord into a grounded, 3-prong receptacle only! 120 Volts 60 HZ. 12 Amps, Service Size 15 Amps Receptacle NEMA 5-15R.

6.0 Operation

⚠ CAUTION

IMPORTANT: DO NOT ATTEMPT TO OPERATE THE CUTTER UNTIL YOU HAVE THOROUGHLY READ AND UNDERSTAND ALL OF THE FOLLOWING INSTRUCTIONS. CALL YOUR AUTHORIZED CHALLENGE DEALER IF YOU STILL HAVE ANY QUESTIONS.

6.1 Console Controls

The console controls consist of a main power switch, inch/mm selector, and knife adjust switch.

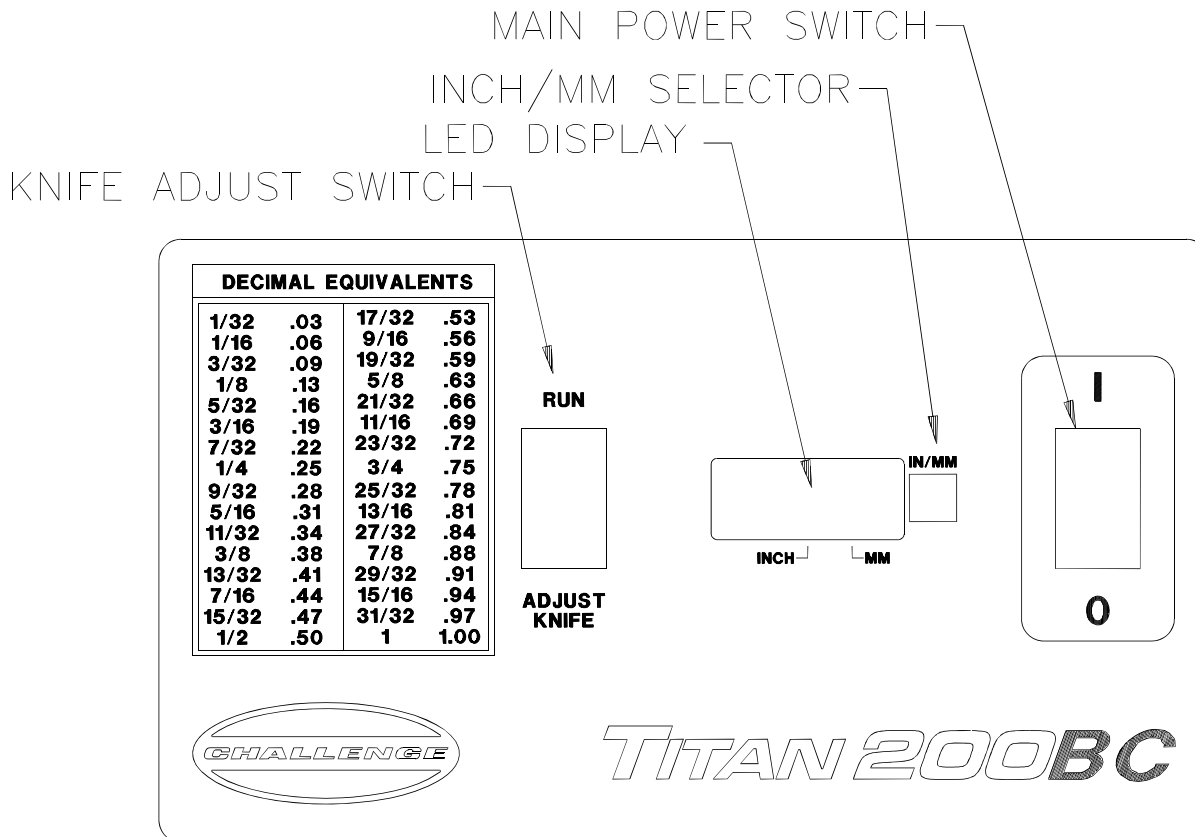

Figure 10

6.2 Making a Cut

Open the front shield and place the paper against the backgauge. Note: If the cut will leave strips of paper less than 1/2" wide, place the paper against the right side guide. This will prevent the strips from getting caught in the small opening near the left side guide.

To make the cut, close the front shield and press both cut buttons located at the front of the machine within 1/2 second of each other. Hold the buttons in until the knife reaches the table. Releasing the cut buttons or raising the shield at any time during the cut cycle will immediately send the knife and clamp to the "up" position.

Note: The shield must be opened and closed each time before making a cut.

6.3 Jogging Aid



CAUTION Always remove the jogging aid from the table before making a cut.

A jogging aid is included as standard equipment with the Titan 200BC. This tool allows the operator to load and align paper without the need to place hands or arms under the knife or clamp.

Load the paper against the side and backgauge using the jogging aid (Figure 11 & Figure 12). Remove the jogging aid from the table, close the shield, and make the cut.

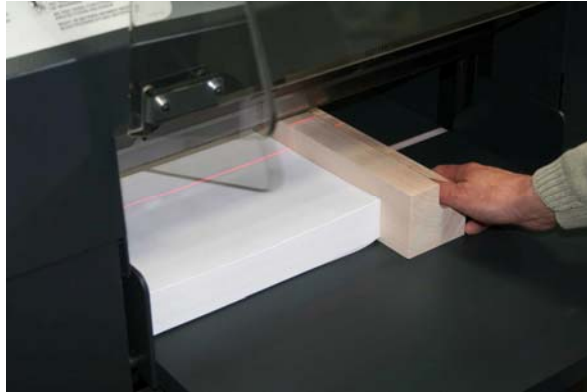

Figure 11

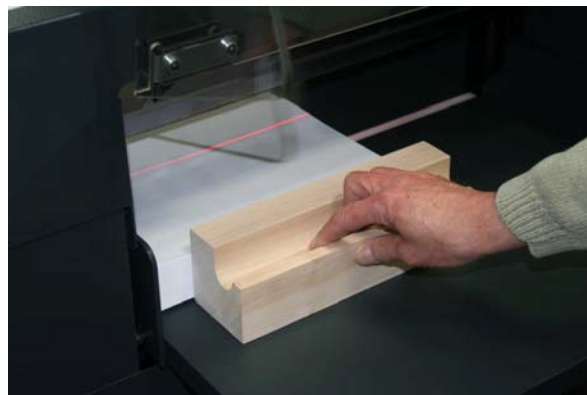

Figure 12

6.4 Backgauge Control

Each time the machine is switched on, the backgauge must be preset. Switch on the machine. The display will read all dashes. If the backgauge is closer than 5 inches (127mm), move the backgauge further than 5 inches (127mm) then bring it forward again until numbers are displayed. If the backgauge is further than 5 inches (127mm), bring it forward until numbers are displayed.

The hand wheel operated lead screw moves the backgauge to position stock for cutting. The backgauge position is shown with an LED display. **The backgauge should always be brought forward to the cut position to eliminate any slack in the lead screw/backgauge components. Inaccurate cutting will result if positioned while moving from a smaller dimension to a larger dimension.** The right-most LED will flash until the backgauge is at optimal position for the dimension being cut; at which time, the LED will switch to a non-flashing display.

7.0 Knife Installation/Changing

⚠ CAUTION

Changing knives can be very dangerous unless safety precautions are observed and extreme care is taken when handling knives.

- By nature of the machines design, the right end of the knife will be exposed when it is in the knife lifter. Use caution while the knife is in the lifter.
- Make sure knife lifter is properly installed, see instructions following.
- Keep handling of unprotected knives to an absolute minimum.
- Clear off cutter table before removing knife.
- Have scabbard on cutter table and insert knife immediately.
- Warn people of any unprotected knife.
- Knife changing is a **ONE PERSON OPERATION**. Having more than one person change knives is potentially dangerous.

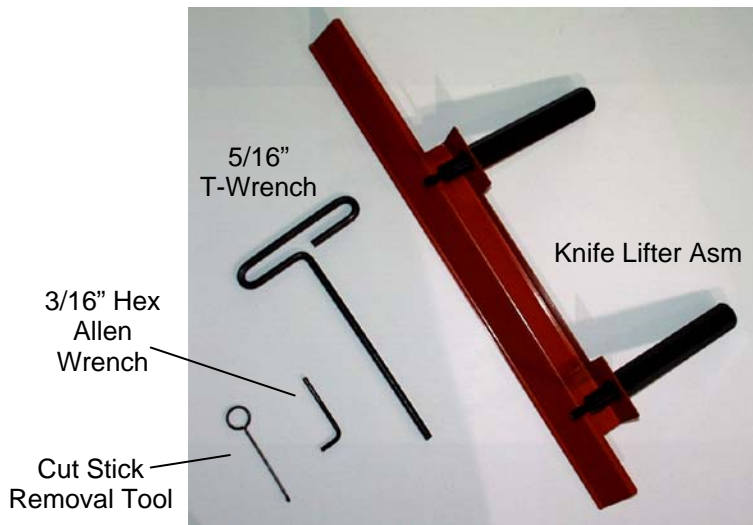

Figure 13 – Knife Changing Equipment

The knife changing equipment shown in Figure 13 is included in the cutter tool kit. The following instructions show how to remove and install a new or re-sharpened knife. Read through these instructions **AT LEAST ONCE** before attempting to actually change or install any blades.

7.1 Knife Removal

1. Make sure the knife and clamp is in the up position. Switch the main power to the OFF position and disconnect the machine power cord to prevent accidental power-up while servicing the cutter.
2. Back off the knife adjusting screws on top of the knife bar several turns (Figure 14, pg 24). A new knife will cut deeper than one that has been ground several times. Failure to back off the screws could damage the knife and/or the cutting stick.



Figure 14

3. Remove the knife bolts from the two slotted knife bar holes and replace with the knife lifter assembly (Figure 15). Tighten the lifters to hold the knife in place, and then remove the remaining knife bolts.

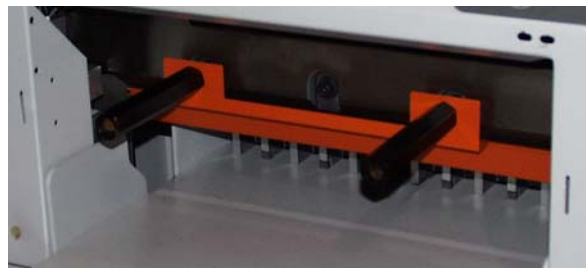

Figure 15

4. Clear the table surfaces and place the empty knife scabbard on the table. Remove the scabbard's knife retaining screws.
5. Grasp the knife lifter handles firmly and, at the same time, turn them counterclockwise to release the knife from the knife bar (Figure 16). Lower the left end first, then lower the right end as you shift the knife sideways to the left. Bring the right end of the knife around the knife bar guide frame. Maneuver the right end into the space between the guide frame and the shroud as the left end is brought clear of the left guide frame. Move the knife to the right then bring the knife out of the cutter, left end first. Put the blade in the scabbard immediately and secure the knife retainer screws.



Figure 16

7.2 Knife Installation

CAUTION

Knives are heavy and always very sharp! Be sure to keep the edge away from your body and keep other people out of the area while handling the blade. Severe lacerations or dismemberment could result from careless handling procedures.

1. Make sure the knife and clamp are in the up position. If they are not, switch on the power using the red and yellow main power switch, close the front shield, and press the cut buttons. This will send the knife and clamp up.
2. Switch off the machine and unplug the power cord.
3. Pull out the cut stick using the cut stick removal tool and turn it to a new surface. If the cut stick is not level or flush with the table, 1/2"/6mm strips of paper can be placed in the table slot under the cut stick to shim it.
4. Remove the retainer screws from the new blade and screw the knife lifters into the new blade. Screw the lifters all the way in and then back them out a 3/4 turn.
5. Remove the other scabbard retainer screw.
6. Double check to make sure the knife adjusting screws have been backed out all the way (step #2, Knife Removal). Lift the blade and insert it into the knife bar slot. Guide the blade, right edge first, into the space between the shroud and the knife bar guide frames. Tip to clear the table side guides, then move the left end of the blade into the knife bar slot dropping the left end as the right end is brought around the right knife bar guide frame and up into the knife bar slot. Raise the knife into the knife bar slot as high as it will go and tighten the lifters.

NOTE: If the blade will not go in, either the lifters are screwed into the blade too far, or the end of the blade is hitting the cylinder bracket at the right end of the knife slot. In this case, drop the left end when inserting the knife.

7. Insert the knife bolts with washers and snug to hold the knife, but do not tighten them yet.
8. Remove the knife lifters and replace with bolts and washers.
9. Place a few sheets of paper over the cut stick, covering the stick end-to-end.
10. Plug in the power cord and switch power on.
11. Locate the Knife Adjust Switch on the control console. Select the Adjust Knife mode, close the shield, and press the cut buttons to send the knife to the down position
12. Switch power off and disconnect the power cord.
13. Turn the knife adjusters down evenly, a small distance at a time, until the knife cuts through the bottom sheet of paper the entire length of the cut stick (Figure 17). Turning the screws down evenly prevents uneven wear on the knife and cut stick.



Figure 17

14. Plug in the power cord and switch power on. And move the Knife Adjust Switch to the Run mode.
15. Close the front shield and push both cut buttons. This will raise the knife and clamp to the up position.
16. Switch power off and disconnect the power cord.
17. Tighten all knife bolts securely.
18. Plug in the power cord and switch power on. Make a test cut through a full lift of paper and make minor adjustments if necessary by repeating steps 9 through 17. **NOTE:** If the knife ends cut but the middle doesn't, you could have dips or uneven spots in the knife and/or cut stick. These can be eliminated by placing 1/2"/6mm strips of paper in the table slot beneath the cut stick to shim it.
19. Send the dull knife to a knife grinder. Do not attempt to sharpen your own knives! See the Knife Care Tips Section below to determine the knife bevel angle.

7.3 Knife Care Tips

! CAUTION ! KNIFE SAFETY ! Knives are **DANGEROUS!!!** They are heavy and very sharp, even after use. Keep the edge away from your body and keep the area clear of others when handling knives. Never touch the cutting edge! To prevent personal injury and damage to the knife, always keep knives in their holders with screws tightened. You are aware of the dangers, but others may not be. Never attempt to hone, polish, or service the knife in any way. Failure to follow safety procedures may result in severe lacerations or dismemberment.

7.3.1 Knife Blade Life

Knife blade life, or the time between sharpening, can be affected by many factors. One important factor is the type of paper being cut. Abrasive paper, such as recycled paper, soft paper such as newsprint paper, and bound books can all significantly shorten knife blade life. Also, if the knife depth is set too deep, the knife will cut too deep into the cutting stick and can dull the knife blade.

A knife can last between 2,000 and 5,000 cuts before it needs to be sharpened. Cutting soft paper (such as newsprint paper) or paper with high post-consumer recycled content can cause the knife to need sharpening after only 2,000 to 3,000 cuts. Cutting pure paper, such as bond paper with no recycled content, or hard paper can allow the knife to be used for as many as 5,000 cuts before it

needs to be sharpened. In all cases, the operator should continually check the quality of the cut to determine when the knife blade needs to be sharpened. Some characteristics that indicate a blade needs sharpening are:

- The knife hesitates or stalls while making a cut.
- The sheets are not all cut to the same length (usually the top few sheets are longer than the rest of the sheets - this is sometimes called “draw”).
- Cut marks appear on the cut face of the paper.
- The profile of the cut (side view) is not perpendicular to the table.
- The cut does not appear straight when viewed from the top.
- The knife makes a “rougher” sound as it passes through paper.
- Nicks are visible on the cutting edge of the knife.

7.3.2 Cutting Stick

A worn cutting stick can affect the cut quality of the bottom sheets. When this happens, the cut stick can be rotated. Usually, the stick should be rotated one or two times between knife sharpening.

There are 8 possible cut stick positions. The stick can be rotated 4 times, and then turned end to end, and rotated 4 times again.

7.3.3 Bevel Angle

Challenge recommends that bevel angles for the Titan 200BC knives be in the range of 21° to 23°. In general, a 21° bevel angle will provide better cut quality when cutting soft paper (such as newsprint), recycled paper, or bound books. However, 21° angle knives can become dull sooner than 23° knives, which results in shorter knife blade life. A knife with a 23° bevel angle, on the other hand, will not dull as easily, and can provide satisfactory results when cutting most types of paper. Knives shipped with the Titan 200BC from the factory have a bevel angle of 23°.

7.3.4 Helpful Suggestions

- If your shop is large enough to purchase more than one set of knives, have one set beveled at 21° and the other at 23°. Note: A set consists of 3 knives: one in the machine, one as a back up, and one at the grinder.
- If the machine seems to strain but the cut quality is still good, reduce the pile height. You may also carefully apply glycerin to the bevel when cutting hard, coated paper. Tie a cloth to the end of a stick; dip the stick in glycerin, and apply. Never apply by hand! In lieu of glycerin you may lightly rub white bar soap along the bevel. Lubrication will prolong the life of your machine and reduce maintenance.

7.3.5 Knife Care

- To prevent corrosion, knives are coated with light oil. It should be REMOVED WITH CARE.
- While removing or installing a knife, be careful not to allow the edge to bump against the machine. Nicks will result.

- If a knife bolt is damaged, replace it.
- Always keep knife bolts securely tightened.
- Always use the heavy-duty knife bolt washers provided by Challenge. Failure to do so could result in scratching or marring of the clamp face.
- Store knives in a dry environment to prevent corrosion.
- Never attempt to service a knife in any way.

8.0 Lubrication

Switch power off and disconnect the power cord. Remove the top cover. Parts requiring oiling are marked with red paint. See figures Figure 18 through Figure 24 starting on page 24 for oil and grease locations. Figure 18 and Figure 19 require the knife and clamp be in the up position. Figure 28 through 32 require the knife and clamp be down. Wipe off any old or excess grease. Use any brand-name type of grease or light oil to lubricate. Note: the lead screw may be lubricated with grease or oil. Oil has a tendency to run off and must be lubricated more frequently; grease tends to collect paper dust and must be cleaned off periodically.

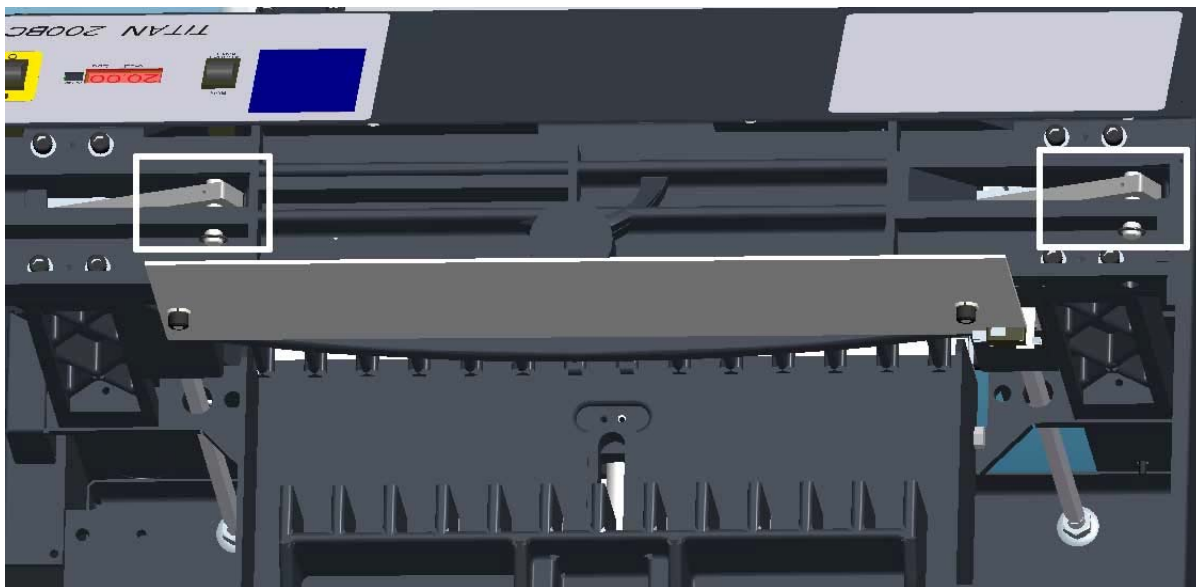
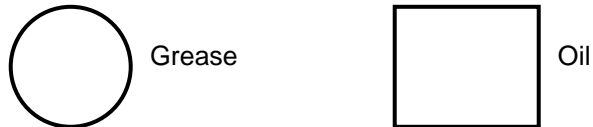

Figure 18 – Knife Bar Links- Upper

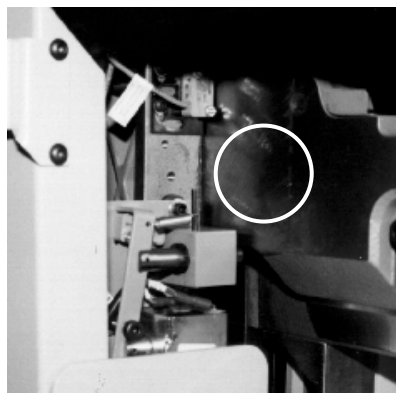

Figure 19 – Knife Bar

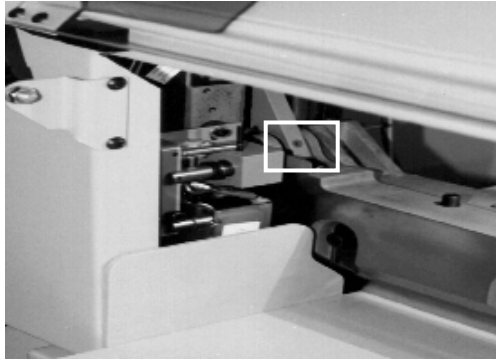

Figure 20 – Knife Bar Link – L.H. Side, Lower

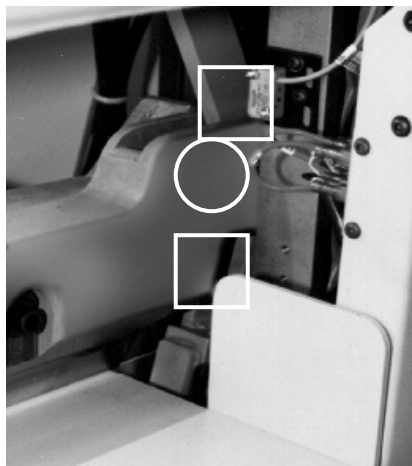

Figure 21 – Knife Bar Link – R.S. Lower, Knife Bar,
Knife Cylinder Bracket, Upper

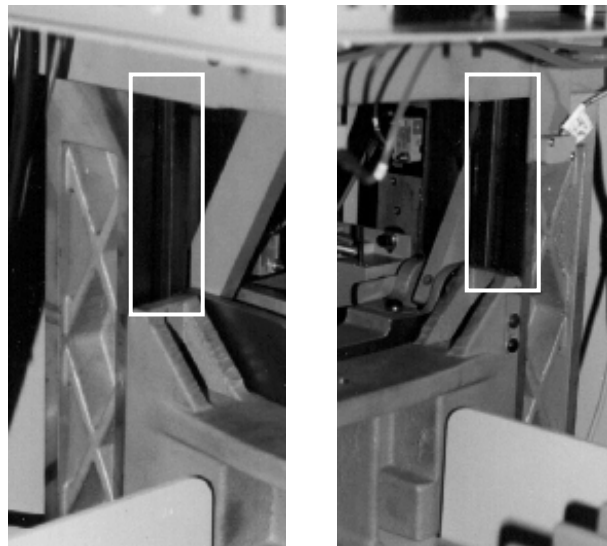

Figure 22 & Figure 23 –Clamp Guides

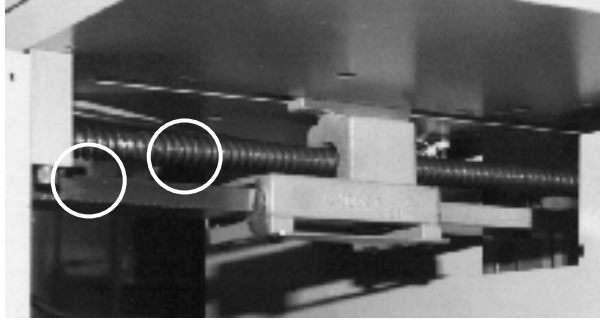

Figure 24 – Lead Screw and Backgauge Guide

9.0 Safety Systems Test

Machine manufacturer CHALLENGEModel TITAN 200BC

Serial Number _____

Frequency of test: **THESE TESTS SHOULD BE PERFORMED AT THE BEGINNING OF EACH WORK DAY.**

Switch power on and make sure the knife and clamp are in the up position (if they are not, follow the instructions in this manual to send them up).

Machines with Front Guards:

Test #1: With the front guard open, press the cut buttons. Nothing should happen. If the knife and/or clamp come down with the front guard open, do not use the machine. Repair or adjustment is needed.

Test #2: Close the front guard and press the cut buttons. While the clamp or knife is coming down, open the front guard. The knife and clamp should immediately return to the up position. If they do not, do not use the machine. Repair or adjustment is needed.

Machines with Electric Eyes:

Test #1: Wave a test object 12mm in diameter between the electric eye beams. The indicator lights should indicate the eyes are blocked. If they do not, do not use the machine. Repair or adjustment is needed.

Test #2: If machine equipped with electric eyes, while making a cut, lean into the electric eye beams. The knife and clamp should immediately return to the up position. If they do not, do not use the machine. Repair or adjustment is needed.

