

# Stapler Folder Model 75 Service Manual

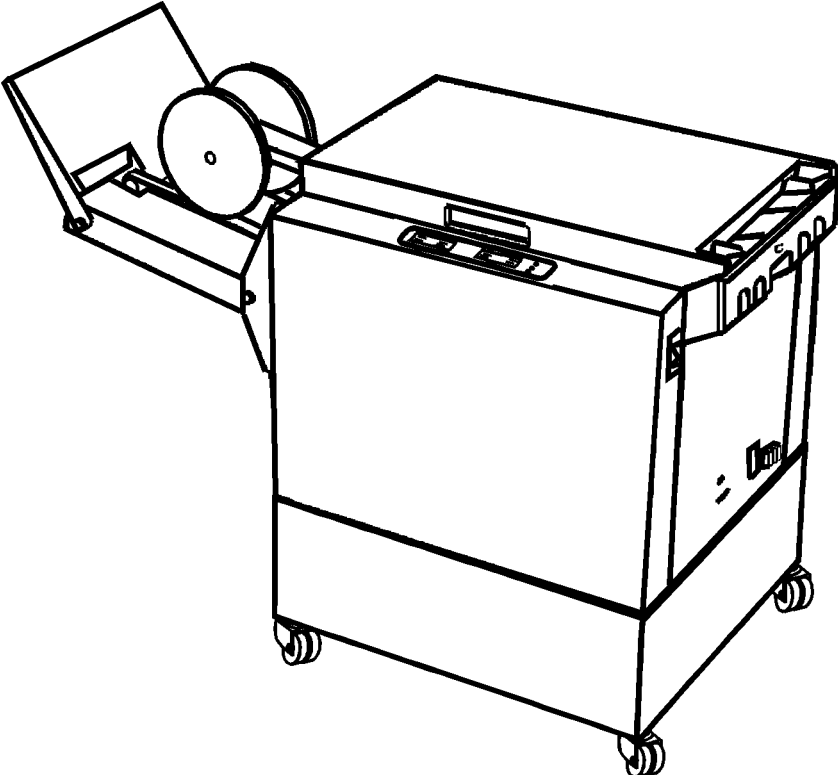

PAGE INTENTIONALLY BLANK

<b>REPAIRS / ADJUSTMENTS (REP)</b>		<b>PAGE</b>	
<b>Cover removal</b>			
REP 1.1	Front and rear cover	1.1.1	November-96
REP 1.2	Top cover	1.2.1	November-96
REP 1.3	Infeed and outfeed cover	1.3.1	November-96
<b>Input area</b>			
REP 2.1	Infeed module	2.1.1	November-96
REP 2.2	Infeed transport belt	2.2.1	November-96
REP 2.3	Rear side guide outer position, Adjustment	2.3.1	November-96
REP 2.4	Rear side guide release solenoid, Adjustment	SOL 3 2.4.1	November-96
REP 2.5	Back jogger motor	MOT 5 2.5.1	November-96
<b>Stapler area</b>			
REP 3.1	Stapler head	3.1.1	November-96
REP 3.2	Staple stop gate release solenoid	SOL 2 3.2.1	November-96
REP 3.3	Staple stop gate position, Adjustment	3.3.1	November-96
REP 3.4	Stapler assembly drive bar position, Adjustment	3.4.1	November-96
REP 3.5	Stapler home position, Adjustment	SW 1 3.5.1	November-96
REP 3.6	Stapler head retraction, Adjustment	3.6.1	November-96
REP 3.7	Saddle stapling sensor, Adjustment	SEN 1 3.7.1	November-96
<b>Output area</b>			
REP 4.1	Upper folder rolls	4.1.1	November-96
REP 4.2	Lower folder rolls	4.2.1	November-96
REP 4.3	Fold pressure, Adjustment	4.3.1	November-96
REP 4.4	Fold knife home position, Adjustment	SW 2 4.4.1	November-96
REP 4.5	Outfeed sensor, Adjustment	SEN 4 4.5.1	November-96
<b>Staple/Fold quality adjustments</b>			
REP 5.1	Staple stop gate parallelism, Adjustment	5.1.1	November-96
REP 5.2	Staple/Fold position, Adjustment	5.2.1	November-96
REP 5.3	Stapler position to anvil, Adjustment	5.3.1	November-96
REP 5.4	Stapler pressure, Adjustment	5.4.1	November-96
REP 5.5	Stapled set transport drive alignment, Adjustment	5.5.1	November-96
REP 5.6	Pressure roller height, Adjustment	5.6.1	November-96
REP 5.7	Stapled set transport solenoid, Adjustment	SOL 1 5.7.1	November-96
<b>PROGRAMMING (PRG)</b>			
PRG 6.1	Reset of EE-prom values	6.1.1	November-96
<b>ELECTRICAL DETAIL INFORMATION (EDI)</b>			
EDI 7.1	Wiring diagram PL75	7.1.1	November-96
EDI 7.2	Connection cable diagram PL75	7.2.1	November-96
EDI 7.3	Electrical components list	7.3.1	November-96
EDI 7.4	Electrical components location	7.4.1	November-96
EDI 7.5	Test points	7.5.1	November-96
<b>FAULT ISOLATING PROCEDURE (FIP)</b>			
FIP 8.1	Self diagnostic system control (SDS)	8.1.1	November-96

### REMOVAL

#### Front cover

1. Switch off the main power switch and disconnect the power cord.
2. Open the Top cover and loosen the two screws (1) securing the top end of the Front cover.
3. Loosen the two nuts (2).
4. Pull out the lower end and lift up carefully to remove.

#### Rear cover

Removal of the rear cover is performed the same way as removal of the front cover.

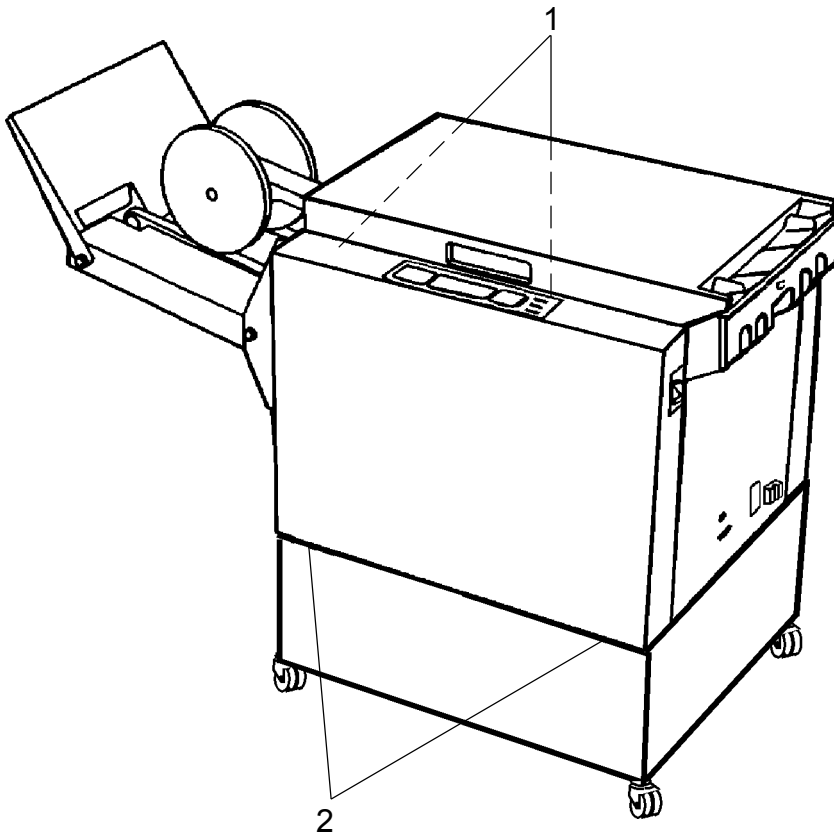

### INSTALLATION

Installation is an exact reversed procedure of removal.

### REMOVAL

1. Open the Top Cover
2. Disconnect the Gas spring (4).
3. Remove the four nuts and spacers and the two screws (1) from the brackets.
4. Lift off the Top cover.

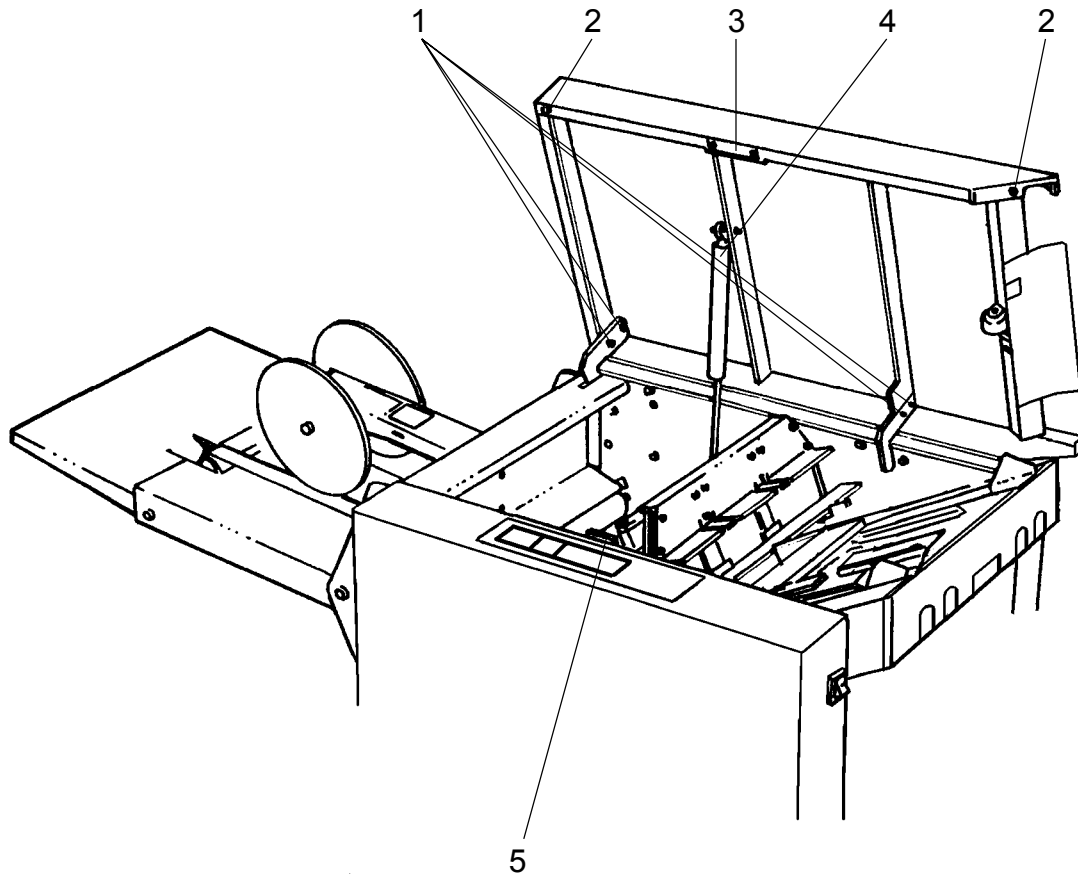

### INSTALLATION

1. Mount the four nuts and spacers and the two screws (1) onto the brackets and tighten.
2. Connect the Gas spring (4).
3. Close the Top cover and check:
  - That the magnet (5) locks on the sheet plate (3).
  - That both rubber bushings (2) contacts the surface.
  - That the Top cover front side is parallel to the front cover.
  - That the Interlock switch activates when the distance between the magnet (5) and the sheet plate (3) is 2 to 5 mm.

### ADJUSTMENT

1. Loosen the screws and nuts (1).
2. Move the Top cover to adjust.
3. Tighten the screws and nuts (1).
4. Repeat the check.

## REMOVAL

### Infeed cover

1. Switch off the main power switch and disconnect the power cord.
2. If the unit is online, disconnect the connection cable.
3. Loosen the two nuts (1).
4. Pull out the lower end of the infeed cover and remove the cover down wards.

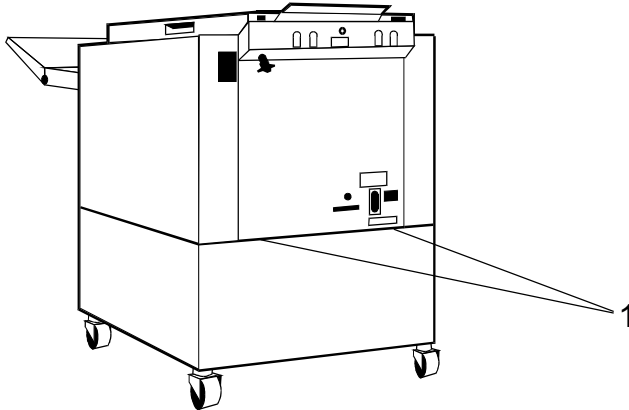

### Outfeed cover

1. Switch off the main power switch and disconnect the power cord.
2. Remove front and rear cover according to REP 1.1.
3. Loosen the two screws below the stacker frame securing the stacker.
4. Disconnect and remove the stacker (3).
5. Tip the model 75 by placing 50 mm or greater distances between the outfeed end of the Model 75 and the base.
6. Loosen the two screws (5) securing the outfeed bottom cover.
7. Slide the bottom cover towards the outfeed, until it releases from the infeed bottom cover. Slide the bottom cover towards the infeed until it releases from the screws (5).
8. Remove the four screws (4).
9. Pull the cover carefully out to avoid damage on the outfeed sensor harness on the front side.

**NOTE:** Cut the ty-wraps and disconnect the outfeed sensor to fully remove the outfeed cover.

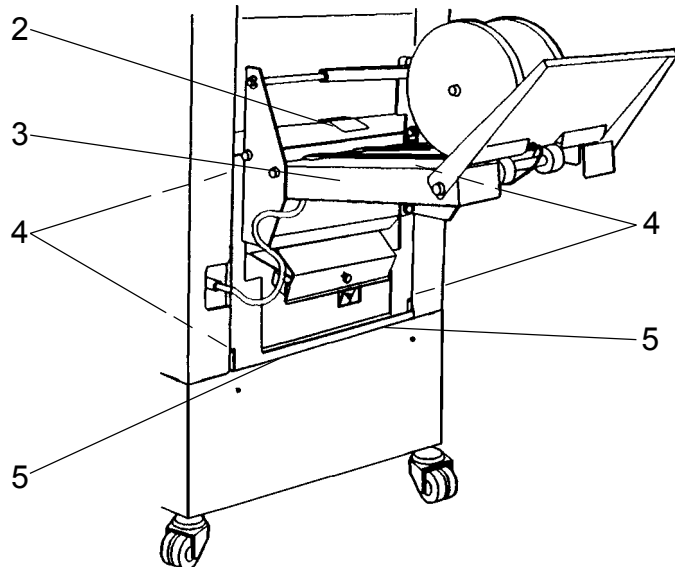

## INSTALLATION

Installation is an exact reversed procedure of removal.

**NOTE:** Make sure the plastic guide (2) does not get jammed between the stackers left side and the outfeed cover when installing the stacker.

### REMOVAL

1. Remove the front and rear cover according to REP 1.1.
2. Remove the infeed cover according to REP 1.3
3. Disconnect the five connectors (1).
4. Remove the spring (2).
5. Disconnect the length adjust strap (3).

VIEW INSIDE INFEED COVER

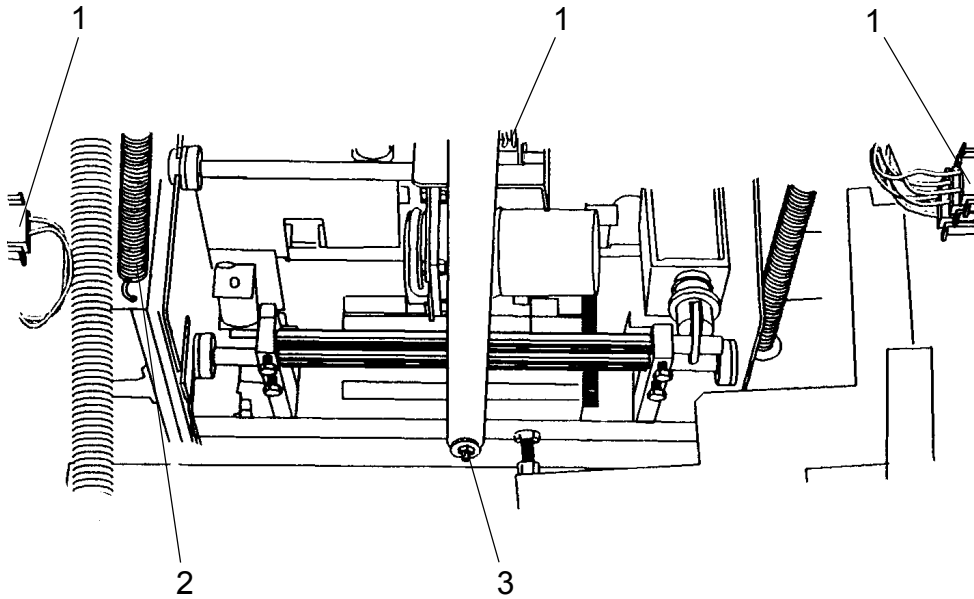

6. Remove the two screws (5) on the front side.
7. Remove the two screws (5) on the rear side.
8. Lift out the Infeed module (4).

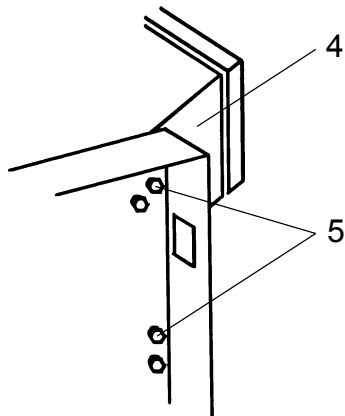

### INSTALLATION

Installation is an exact reversed procedure of removal.

### REMOVAL

1. Switch off the main power switch and disconnect the power cord.
2. Remove the Infeed module according to REP 2.1
3. Remove the four screws (1).
4. Slide the drive coupling (5) off of the drive shaft (4) and remove the transport belt assembly.
5. Remove the belt (2) from the assembly.

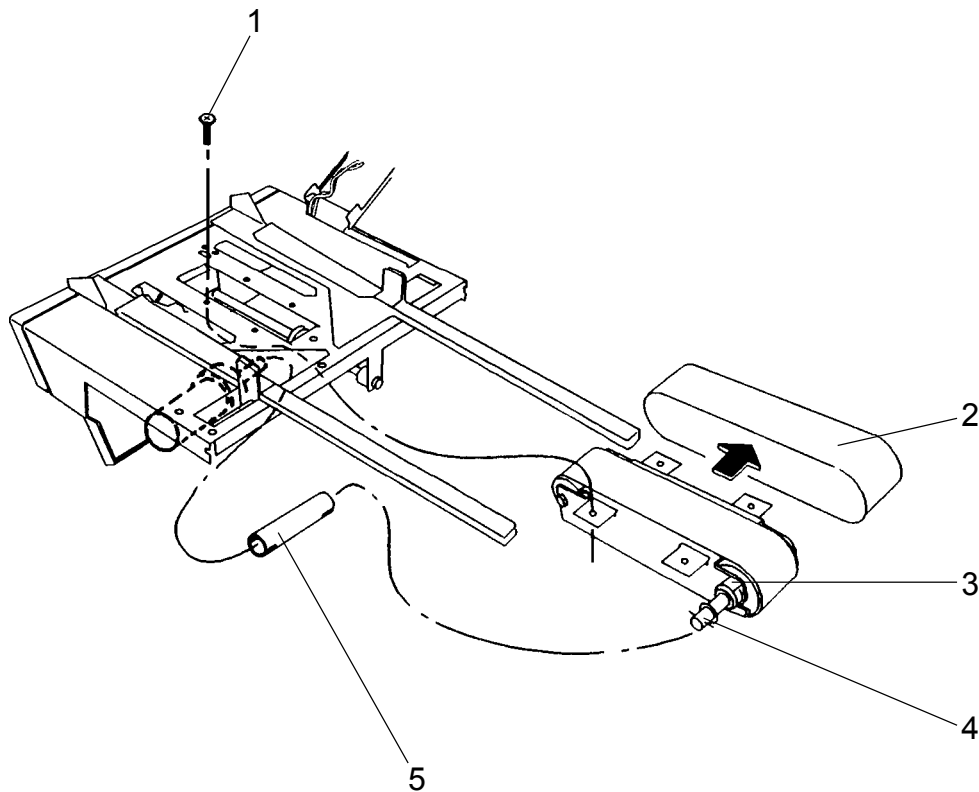

### INSTALLATION

Installation is an exact reversed procedure of removal.

**Note:** Make sure the flat side on the bearing (3) is up when installing.

## REP 2.3 Rear side guide outer position, adjustment

T08039

### PURPOSE

The purpose is to ensure that the rear side guide reaches the home position.

**NOTE:** *This is not a fine adjustment of the rear side guides outer position. The outer position of the rear side guide is fixed.*

1. Make sure the stapler heads are in home position (that the motor linkage (5) is in top dead center).
2. Switch off the main power switch and disconnect the power cord.
3. Remove the infeed cover according to REP 1.3.

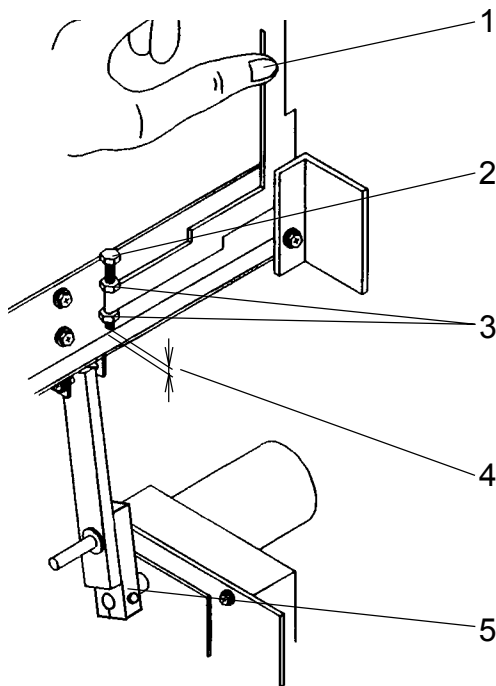

### ADJUSTMENT

1. Push at the top (1) for maximum leverage.
2. Check that the gap (4) is  $1.5 \pm 1.0$  mm.
3. Loosen the locknuts (3).
4. Rotate screw (2) to adjust.
5. Tighten the locknuts (3).

### PURPOSE

The purpose is to ensure that the Rear side guide returns to the home position after a set has been run.

1. Switch off the main power switch and disconnect the power cord.
2. Remove the Infeed module according to REP 2.1.

### VIEW FROM BOTTOM OF THE INFEED MODULE

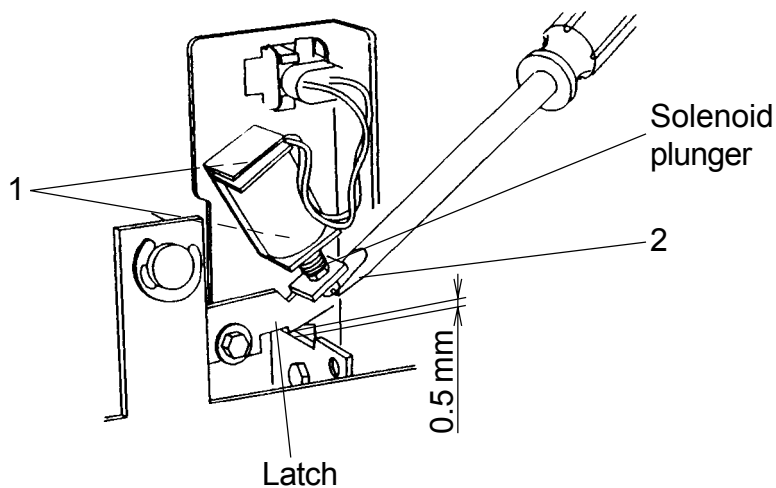

### ADJUSTMENT

1. Adjust the rear side guide to the position where the solenoid plunger is in the innermost position as shown.
2. Push in the solenoid plunger (2).

**Note:** *Push on the solenoid plunger of the solenoid only, do not push on the latch. If pushing on latch the measurement will be inaccurate.*

3. Insert a feeler gauge to check that the gap is 0.5 mm.
4. Loosen the two screws (1) from the back side of the bracket.
5. Move the solenoid to adjust.
6. Tighten the screws (1).

### REMOVAL

1. Switch off the main power and disconnect the power cord.
2. Remove the infeed module according to REP 2.1.
3. Disconnect the ground wire (1).
4. Loosen the setscrew in the collar (3).
5. Remove the motor (2).

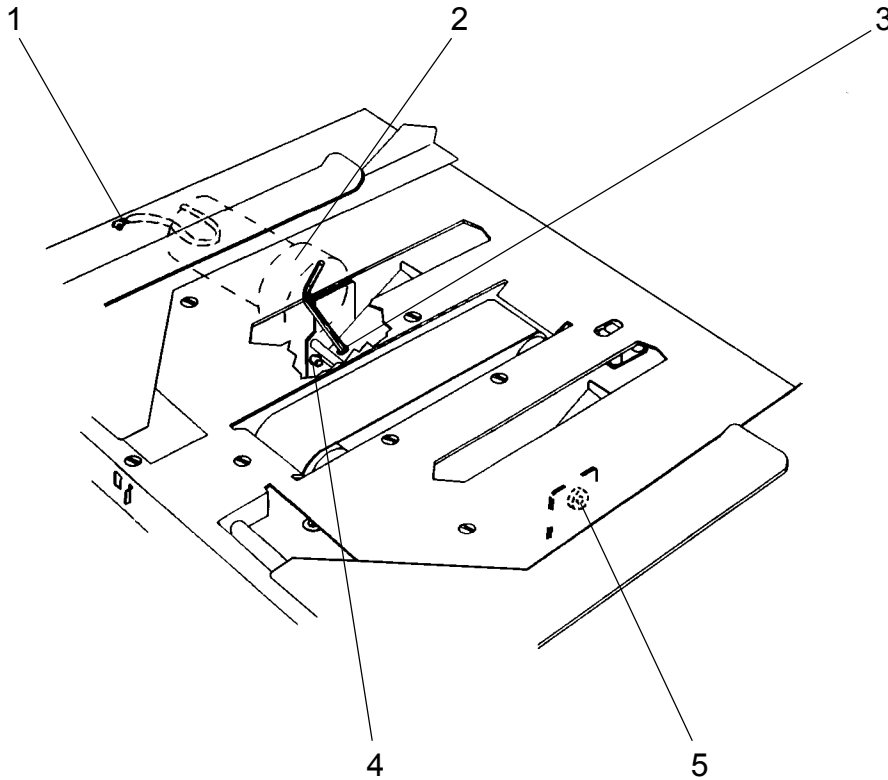

### INSTALLATION

1. Install the motor.
2. Ensure that the pin on the motor is inserted in the grommet (4).
3. Push the collar (5) of the flange bushing firmly against the bracket.
4. Tighten the setscrew (3) on the flat of the shaft.
5. Connect the ground wire (1).
6. Install the infeed module according to REP 2.1.
7. Check/adjust the Staple/fold position according to REP 5.2.

### REMOVAL

1. Switch off the main power switch and disconnect the power cord.
2. Disconnect the staple detection lead (5).
3. Push down latch (2) and lift the stapler head (1) out.

**NOTE:** *If removing the stapler head use the pivot pin (6) from the old stapler head and install it in the new head.*

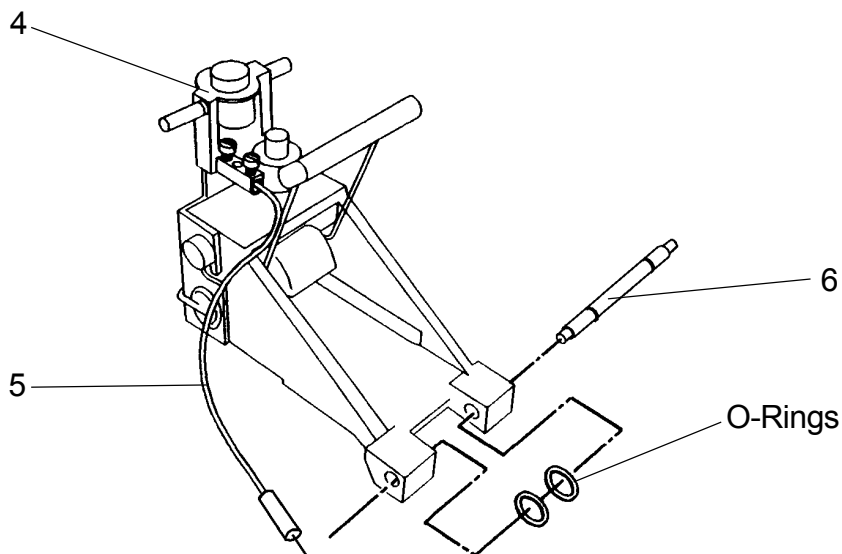
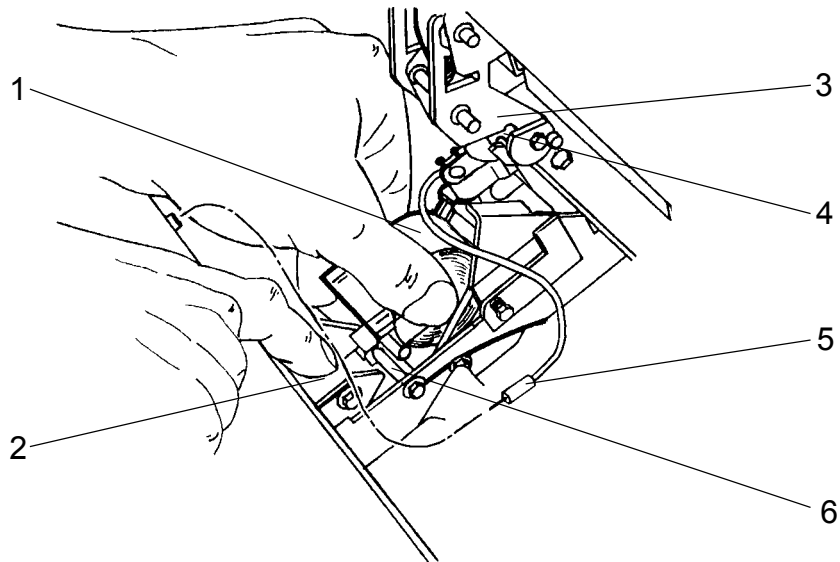

### INSTALLATION

1. Install the plunger (4) in the plunger retraction swing arm (3).
2. Push the Stapler head down so that the pivot pin (6) locks under the latch (2).
3. Connect the staple detection lead (1).

### REMOVAL

1. Move the front side guide to the outermost position.
2. Adjust the sheet size on the control panel to align the mounting screws (2) for the solenoid with the access holes (1) in the paper path.
3. Switch off the main power switch and disconnect the power cord.
4. Remove the infeed cover according to REP 1.3.
5. Cut the ty-wrap securing the cable.
6. Disconnect the solenoid connector.
7. Loosen the two screws (2).
8. Slide the solenoid towards the infeeder to remove.

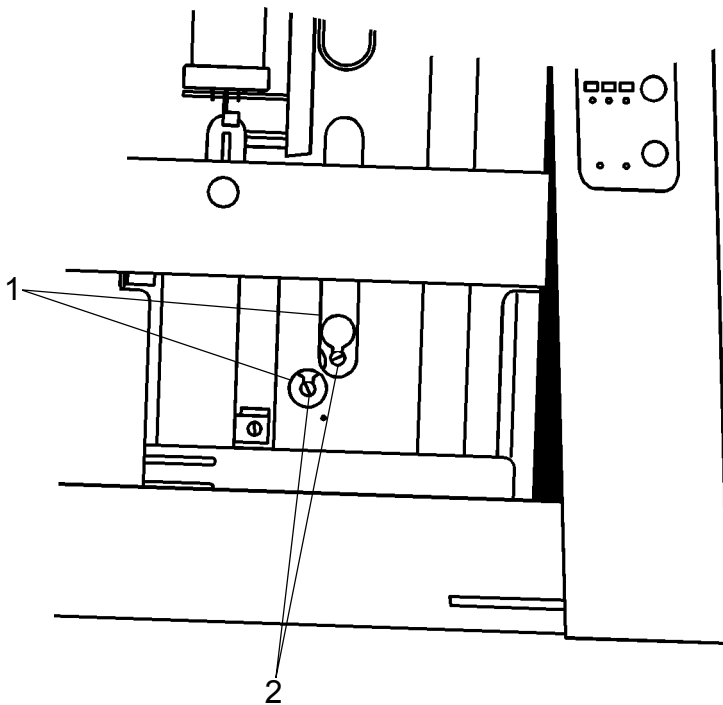

### INSTALLATION

Installation is an exact procedure of removal.

### PURPOSE

The purpose is to position the Staple stop gate fingers in the center of each opening in the paper path so that binding does not occur.

1. Adjust to the smallest sheet size on the control panel.
2. Switch off the main power switch and disconnect the power cord.
3. Remove the Infeed cover according to REP 1.3.
4. Insert a 0.3 mm feeler gauge (3) to ensure  $0.3 \pm 0.2$  mm endplay.
5. Disengage the Staple stop gate release solenoid (1).

VIEW INSIDE INFEED COVER

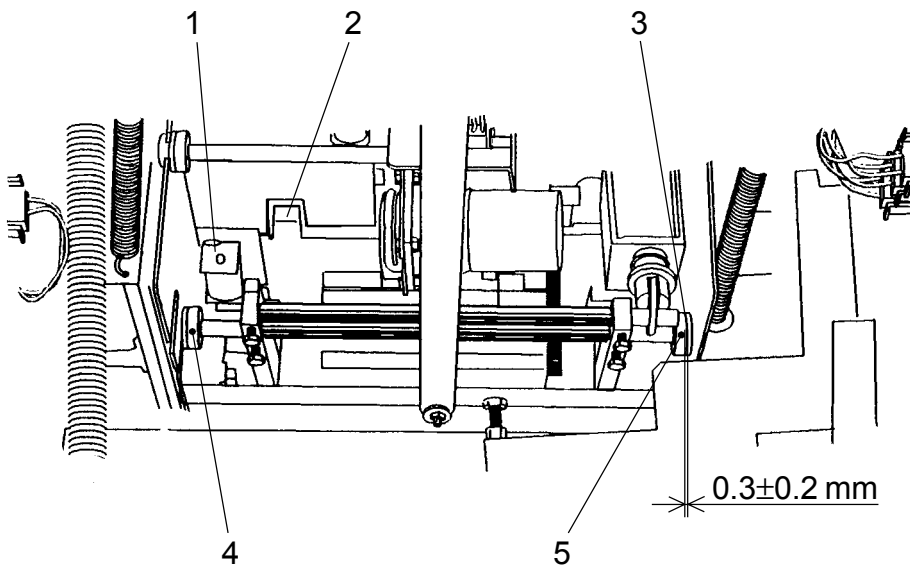

### ADJUSTMENT

1. Check that the fingers (2) are centered in the openings in the paper path.
2. Loosen the two allen screws (4)(5) securing the collars.
3. Center the fingers (2).
4. Tighten the front allen screws (4).
5. Insert a 0.3 mm feeler gauge (3) to obtain  $0.3 \pm 0.2$  mm endplay.
6. Tighten the rear allen screw (5).

### PURPOSE

The purpose is to limit the front-to-rear movement of the Stapler assembly drive bars without causing them to bind.

1. Switch off the main power switch and disconnect the power cord.
2. Remove the Infeed cover according to REP 1.3.
3. Remove the Front cover according to REP 1.1.

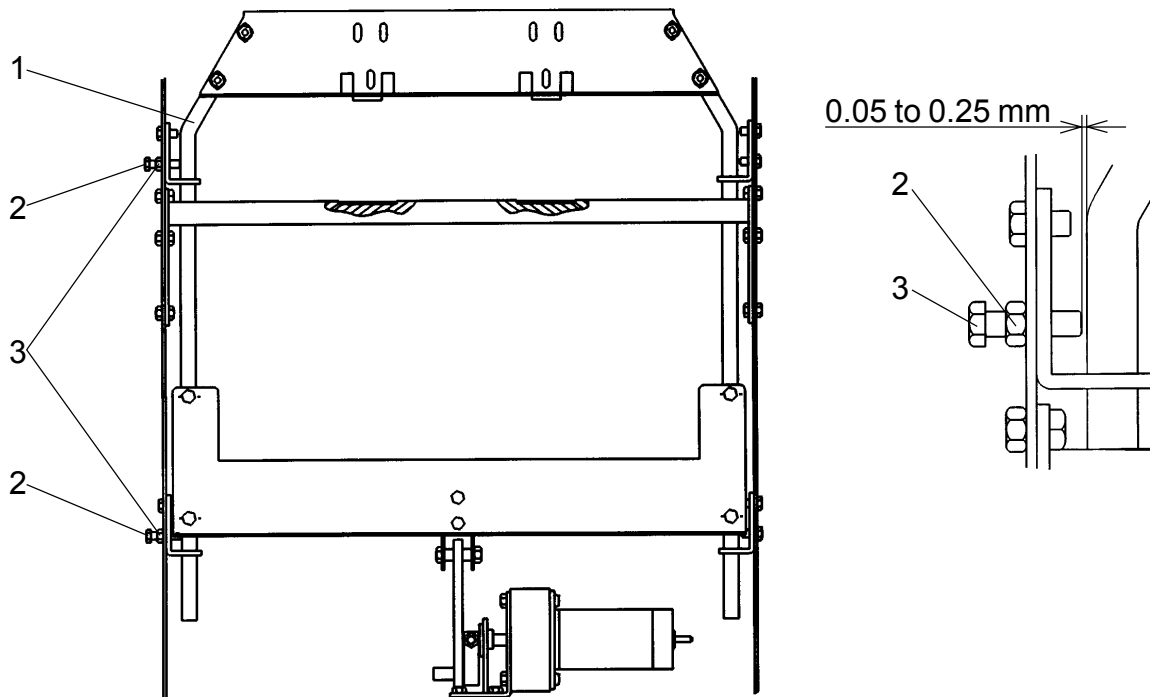

### ADJUSTMENT

#### Top bearing

1. Push the drive bar (1) toward the rear.
2. Insert a feeler gauge to check that the gap is 0.05 mm to 0.25 mm.
3. Loosen the locknut (3).
4. Rotate the screw (2) to adjust.
5. Tighten the locknut (3).

#### Bottom bearing

Adjustment of the Bottom bearing is performed the same way as adjustment of the Top bearing.

### PURPOSE

The purpose is to position the Stapler motor home position switch (SW 1) so that the Stapler motor (MOT 8) stops in the correct position after stapling a set.

1. Switch off the main power switch and disconnect the power cord.
2. Remove the infeed cover according to REP 1.3.
3. Rotate the motor linkage (3) to the top dead center.

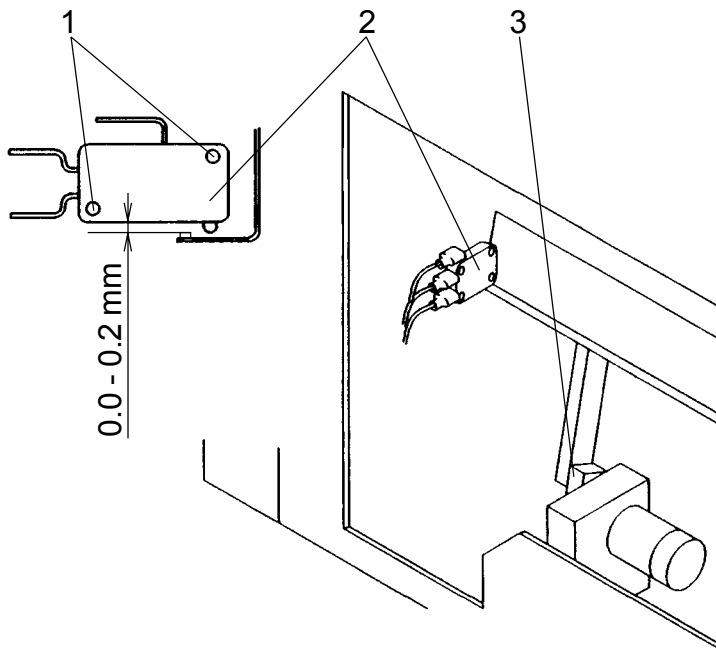

### ADJUSTEMENT

1. Check that the gap is 0.0 mm to 0.2 mm.
2. Loosen the two screws (1).
3. Move the switch (2) to adjust.
4. Tighten the two screws (1).

### PURPOSE

The purpose is to ensure the staple feed.

1. Check/adjust the Stapler home position according to REP 3.5.
2. Switch off the main power switch and disconnect the power cord.

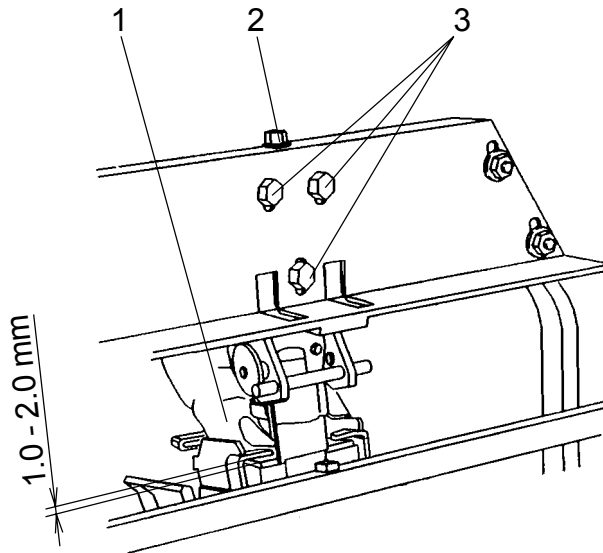

### ADJUSTMENT

1. Push down the stapler head (1).
2. Check that the gap is 1.0 to 2.0 mm.
3. Loosen the three screws (3).
4. Rotate the screw (2) to adjust.
5. Tighten the three screws (3).

### PURPOSE

The purpose is to position the saddle stapling sensor (SEN 1) so that it will switch on the stapler motor (MOT 8) when a set reaches the Staple stop gate.

1. Remove the rear cover according to REP 1.1 and pull out the interlock bypass switch actuator.
2. Remove the nut (1).
3. Remove the black shield (2).

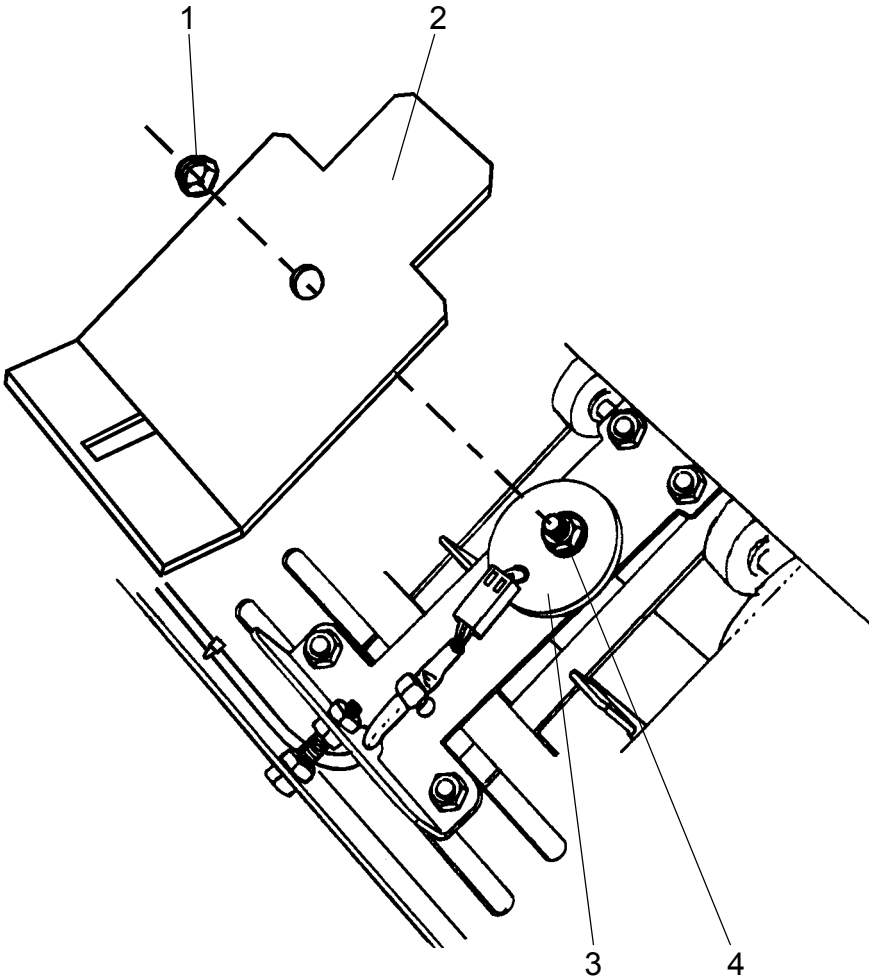

### ADJUSTMENT

1. The voltage between TP1 on the controller PCB and common ground should be greater than 2.2 VDC with the sensor blocked and less than 0.9 VDC unblocked.

**NOTE: Use white paper to block the sensor.**

2. Loosen the nut (4).
3. Move the sensor (3) to obtain the voltages.
4. Tighten the nut (4).

### REMOVAL

1. Switch off the main power and disconnect the power cord.
2. Remove front and rear cover according to REP 1.1.
3. Remove the outfeed cover according to REP 1.3.
4. Remove the drive chain (6).
6. Note the position of the sprockets (2&3) on the shaft. Remove the sprockets and the plastic spacer from the front of the spring-loaded bearing block.
7. Remove the collar and the plastic spacer from the rear of the spring-loaded roll.
8. Remove the front bearing block (4) by removing the two screws from the inside of the machine.
9. Remove the front and rear spring-loaded bearing block assemblies by removing screws (5), front and rear, from the inside of the machine.
10. Note the position of the front plastic bearing (1). Remove the bearing.
11. Pull out the upper fixed roll to remove.
12. Pull out the upper spring-loaded roll to remove.

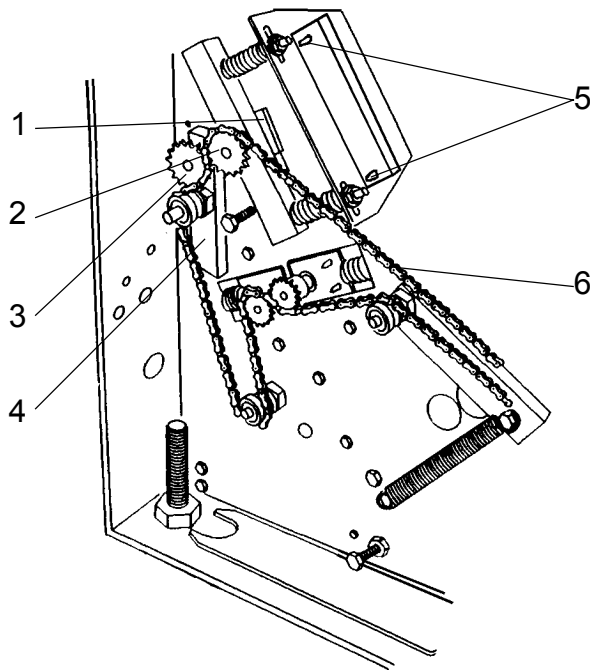

### INSTALLATION / ADJUSTMENT

1. Installation is an exact reversed procedure of removal.

**Note 1:** Push the upper side of the bearing block (4) towards the outfeed before tightening.

**Note 2:** Before tightening the spring-loaded bearing blocks, use a feeler gauge to check that the endplay is 0.1 to 0.5 mm between the sprocket (2) and the plastic spacer. Also check that the endplay on the rear side is 0.1 to 0.5 mm between the collar and the plastic spacer.

2. Adjust the fold pressure according to REP 4.3.

### REMOVAL

#### Lower right folder roll

1. Switch off the main power and disconnect the power cord.
2. Remove front and rear cover according to REP 1.1.
3. Remove the drive chain (3).
4. Note the sprockets (2) position on the shaft and remove the sprocket (2).
5. Remove the spring (4) on both front and rear side.

**WARNING:** *When compressing, pry the spring onto a screwdriver in order to avoid injury when removing it.*

7. Loosen the screws (1) from the inside of the machine.
8. Wiggle the folder roll shaft up and down in order to release it from the brackets (5) securing the shaft.
9. Pull the folder roll through the cut out in the side frame until the shaft releases from the bearing on the opposite side. Then lift out the folder roll through the inside of the machine.

**CAUTION:** *In order to compensate for variations between machines, there could be shim washers placed on the inside of the bushing at the end of the Folder roll shaft. Note the position of the washers when removing.*

#### Lower left folder roll

Removal of the Lower left folder roll is performed the same way as removal of the Lower right folder roll, in addition the Outfeed cover has to be removed according to REP 1.3.

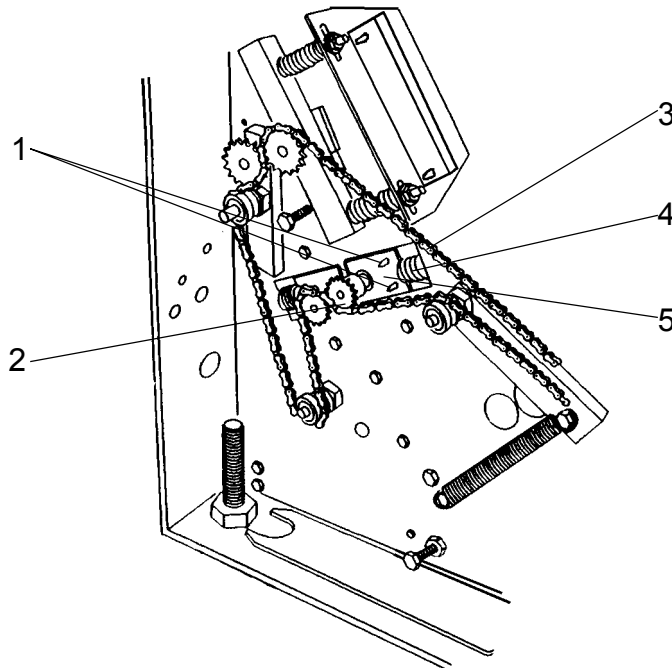

### INSTALLATION

Installation is an exact reversed procedure of removal.

### PURPOSE

The purpose is to ensure that when running 2-5 sheets, only the soft spring (upper spring) will be compressed and when running more than 5 sheets both springs will be compressed.

1. Switch of the main power switch and disconnect the power cord.
2. Remove the front and rear cover according to REP 1.1.

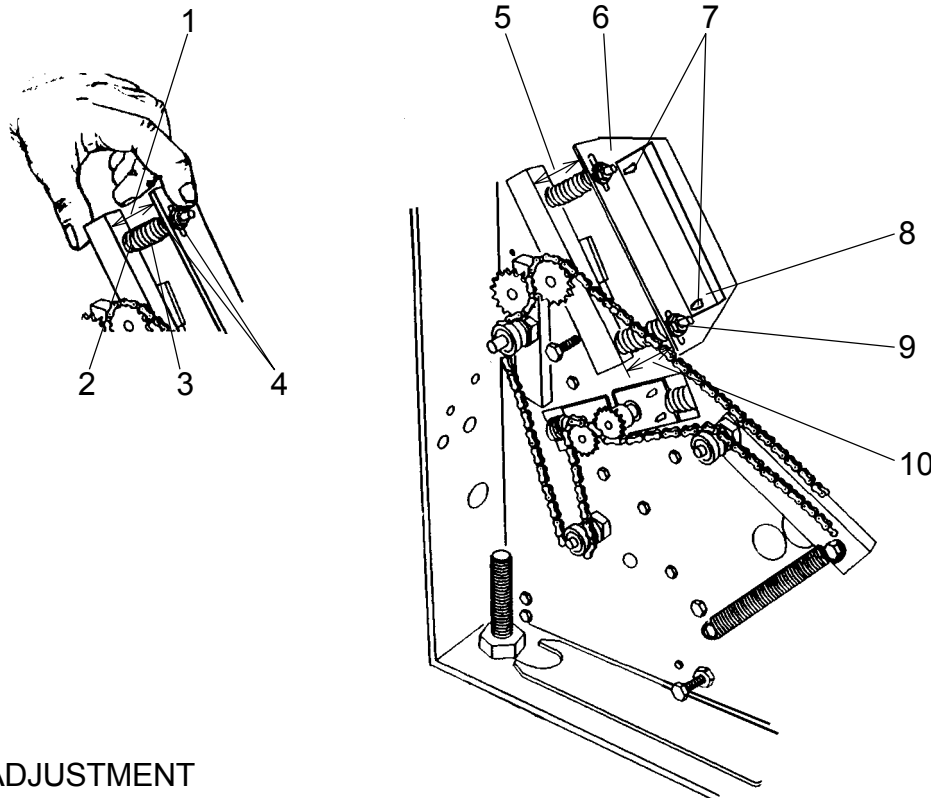

### ADJUSTMENT

#### Front fold pressure assembly

1. Compress upper spring (3) until head of screw (2) contacts bar.
2. Check (1) for  $34.0 \pm 0.5$  mm.
3. Adjust by loosen one nut (4) (Pull spring down to access locking nut) and reposition the other to obtain the dimension. When tightening the nuts make sure the screw is in the outermost position of the slot.
4. Check (10) for  $36.5 \pm 0.5$  mm.
5. Adjust nut (9) to obtain the dimension.
6. Check (5) for  $36.5 \pm 0.5$  mm.

**Note:** Push downwards on the screw (9) when measuring the distance (5).

7. Adjust by loosen the two screws (7) (from the inside of the machine) and reposition the spring bracket (6) to obtain the dimension.  
When tightening the screws make sure the spring bracket (6) is parallel to the nut plate (8) in order to align the folder roll movement with the spring load .

#### Rear fold pressure assembly

Adjustment of the Rear fold pressure assembly is performed the same way as adjustment of the Front fold pressure assembly.

### PURPOSE

The purpose is to ensure that the Fold knife is clear from the paper path in home position.

1. Visually check that the Fold knife is not visible above the paper path.
2. Switch of the main power switch and disconnect the power cord.
3. Remove the outfeed cover according to REP 1.3.
4. Rotate linkage (4) to the down dead center.

SHOWN IN TIPPED POSITION FOR CLARITY

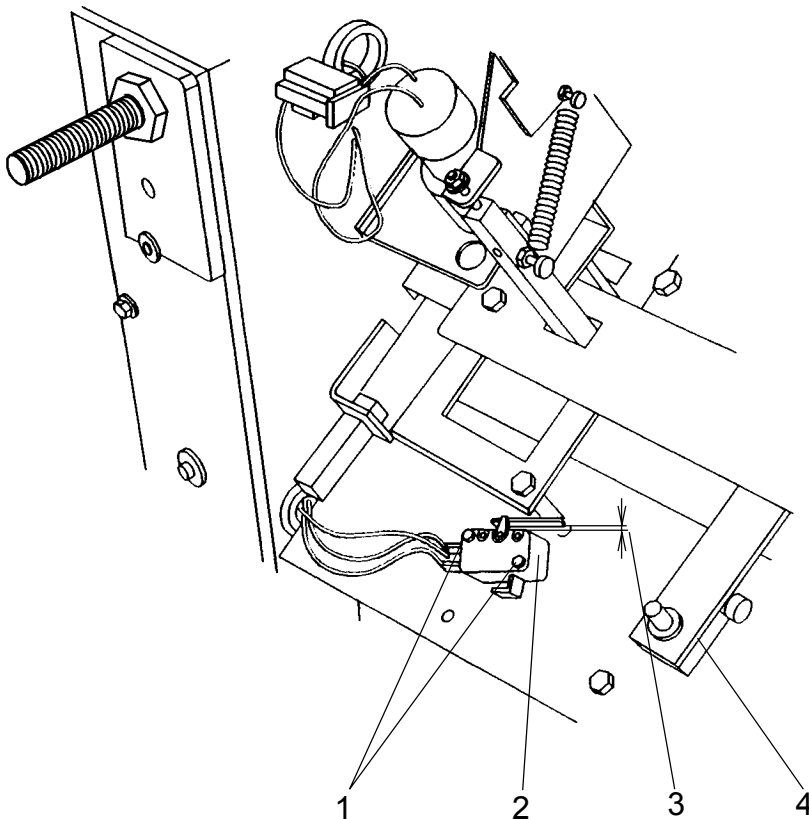

### ADJUSTMENT

1. Check that the gap (3) between the switch housing and the actuator arm is 0.1 mm to 0.5 mm.
2. Loosen the two screws (1).
3. Move the switch (2) to adjust.
4. Tighten the two screws (1).

### PURPOSE

The purpose is to position the Outfeed sensor (SEN 4) so that it will switch on the Stacker motor (MOT 1) when a set enters the stacker tray.

1. Remove the rear cover according to REP 1.1 and pull out the interlock bypass switch actuator.

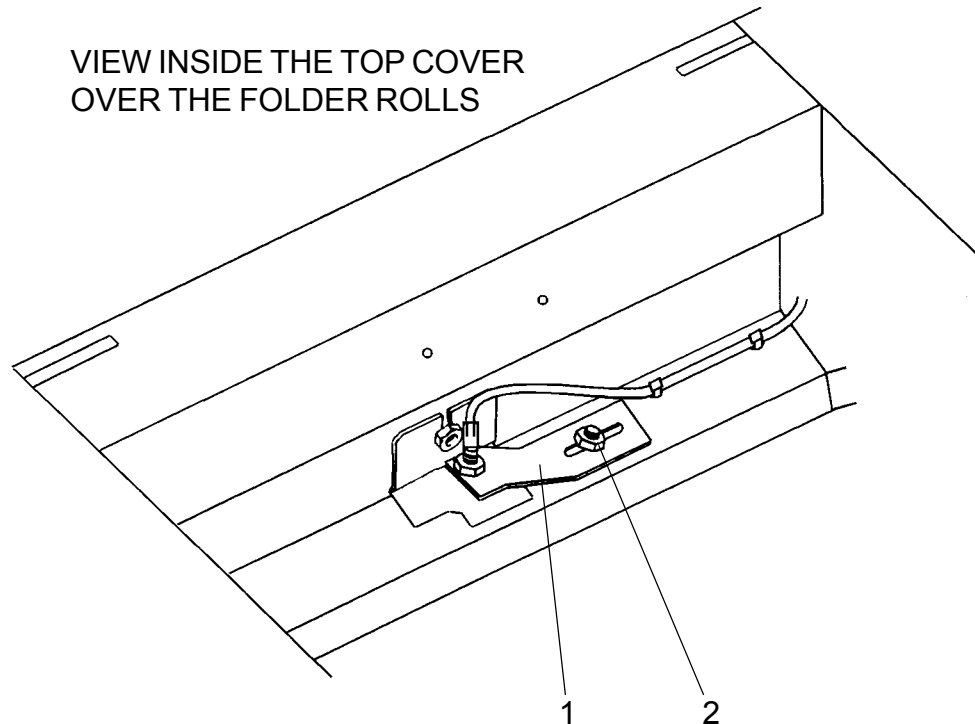

### ADJUSTMENT

1. The voltage between TP8 on the controller PCB and common ground should be greater than 2.2 VDC with the sensor blocked and less than 0.9 VDC unblocked.

**NOTE: Use white paper to block the sensor.**

2. Loosen the nut (2).
3. Move the bracket (1) to obtain the voltages.
4. Tighten the nut (2).

PAGE INTENTIONALLY BLANK

### PURPOSE

The purpose is to ensure that the staples are parallel to the edge of the sets.

1. Remove the rear Stapler head according to REP 3.1.
2. Move the side guides to the outermost position.
3. Select the Fold mode on the Control panel.
4. Select the Adjustment mode on the Control panel.
5. Fold an A4 (8.5" x 11") sheet of paper lengthwise by hand in order to form a straight edge.
6. Feed the folded paper sidewise into the machine so that the straight edge fold (2) is positioned against the Staple stop gate.
7. Adjust the sheet size on the control panel to align the straight edge fold (2) with the locating holes (1) in the paper path.
8. The straight edge fold (2) must align with both of the locating holes (1).

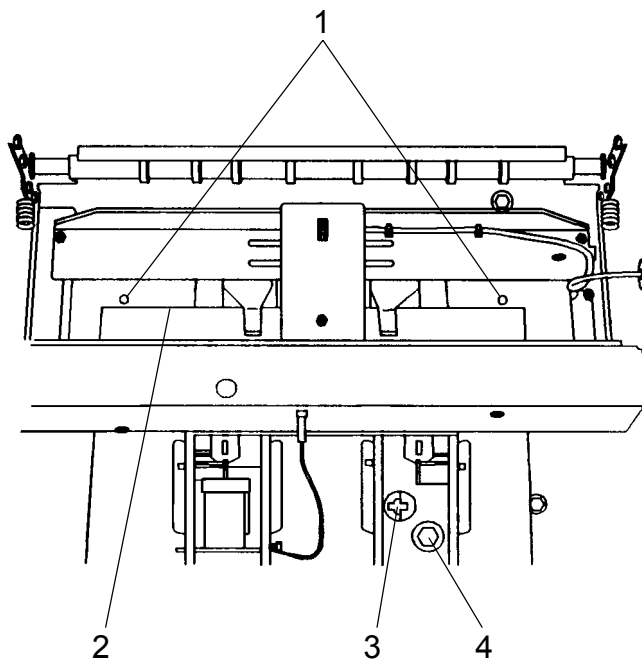

### ADJUSTMENT

1. Loosen the screw (4).
2. Insert a screwdriver in the notches (3) and rotate to align the holes (1) with the straight edge fold (2).
3. Tighten the screw (4).
4. Check/adjust the Staple/Fold position according to REP 5.2.

### PURPOSE

The purpose is to ensure that the sets are folded in the center of the set, that the fold is parallel to the edge of the sets and that the staples are aligned with the fold.

1. Select Fold mode and Adjustment mode on the Control panel
2. Handfeed a 2-sheet set using A4 (8.5"x 11") paper.
3. Adjust the sheet size on the control panel to align the Back jogger with the trail edge of the set without producing a buckle in the set.
4. Select Run mode and run a few sets.
5. Check that the fold is parallel to the edge of the set. If not perform Adjustment 1.

**NOTE: After adjustment 1 is performed , return to this procedure and continue from step 1.**

6. Check that the fold is in the center of the set (that the edges of the booklet are aligned).  
If not perform Adjustment 3.

**NOTE: After adjustment 3 is performed , return to this procedure and continue.**

7. Repeat step 1 to 4 but run 4-sheet sets in Staple/Fold mode.
8. Check that the staples are aligned with the fold. If not perform Adjustment 2.

SHOWN IN TIPPED POSITION FOR CLARITY

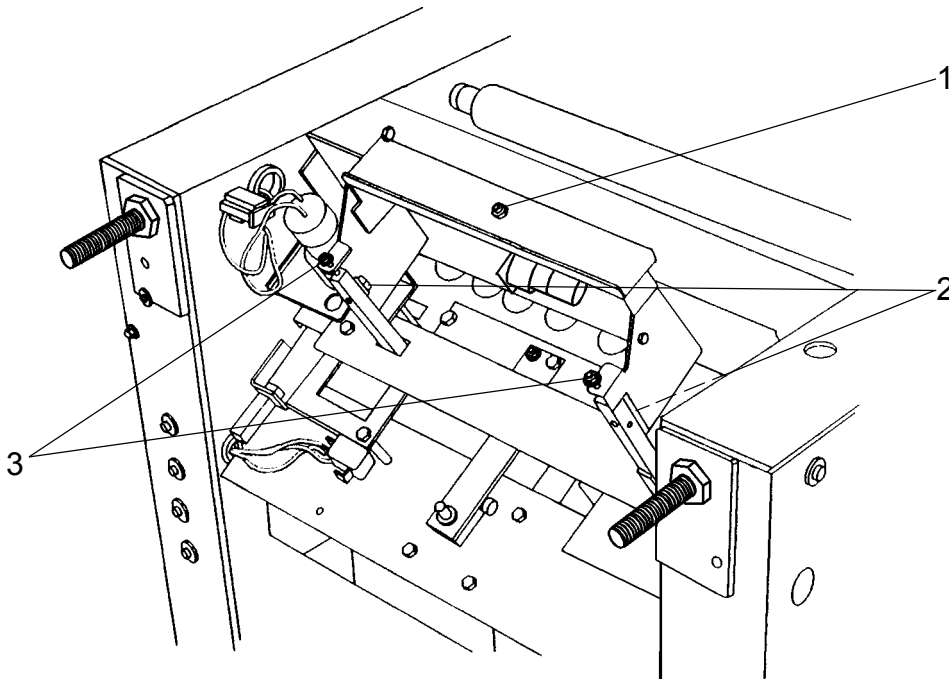

### ADJUSTMENT 1

1. Adjust to the largest sheet size on the control panel.
2. Place the stacker module in upright position.
3. Switch off the main power switch and disconnect the power cord.
4. Loosen the two mounting screws (2).
5. Rotate the two screws (3) to adjust.
6. Push in the fold stop assembly when tighten the two screws (2).
7. Repeat Adjustment 1 until the fold is parallel to the edge of the set.

### ADJUSTMENT 2

1. Loosen the locknut and rotate the setscrew (1) clockwise if the staples are located on the top, counterclockwise if the staples are located on the bottom and tighten the locknut.

**NOTE:** *Top of the booklet is the side that contacts the output wheel.*

2. Repeat Adjustment 2 until the staples are aligned with the fold.

### ADJUSTMENT 3

1. Rotate screw (4) clockwise to lengthen the top of the booklet, counter clockwise to shorten the top of the booklet.

**NOTE:** *Top of the booklet is the side that contacts the output wheel.*

2. Select Adjustment mode on the Control panel
3. Handfeed a 2-sheet set using A4 (8.5"x 11") paper.
4. Adjust the sheet size on the control panel to align the Back jogger with the trail edge of the set without producing a buckle in the set.
5. Select Run mode and run a few sets.
6. Repeat Adjustment 3 until the edges of the booklet are aligned.

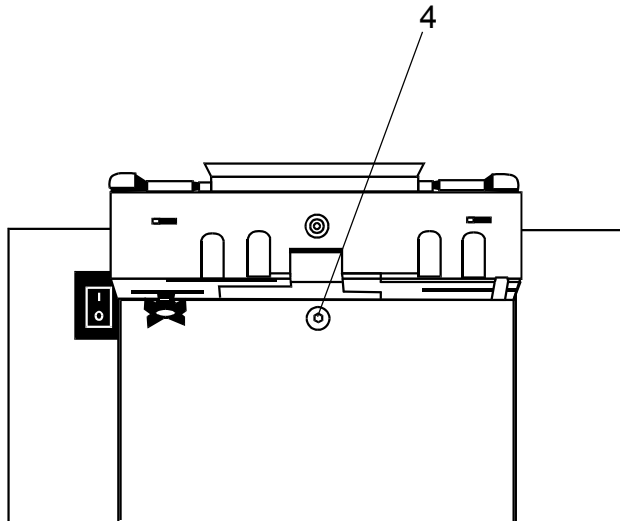

### PURPOSE

The purpose is to ensure that the stapler assemblies are aligned correctly to the anvils.

1. Run a 2-sheet set in the edge staple mode.
2. Check that the staples are formed properly. The ends of the staples should be folded so that they are aligned with the middle of the staple.



3. Switch off the main power switch and disconnect the power cord.
4. Remove the Stapler head according to REP 3.1.
5. Push the plunger (4) manually and note where the staple exits the Stapler head, then return the plunger to the home position.

**WARNING:** *Be careful when handling the Stapler head. The ends of the staples are sharp and difficult to see.*

6. Remove the Staple cartridge (3) and tear the staples at the tear line.
7. Reinstall the cartridge (3) but do not make any staple strokes.
8. Position an allen wrench (2) - app. 2 mm - as shown to relieve the pressure on the staple former.
9. Install the Alignment tool (1) as shown.

**NOTE:** *Head alignment tool is located at the bottom of the front side frame.*

10. Remove the allen wrench (2).

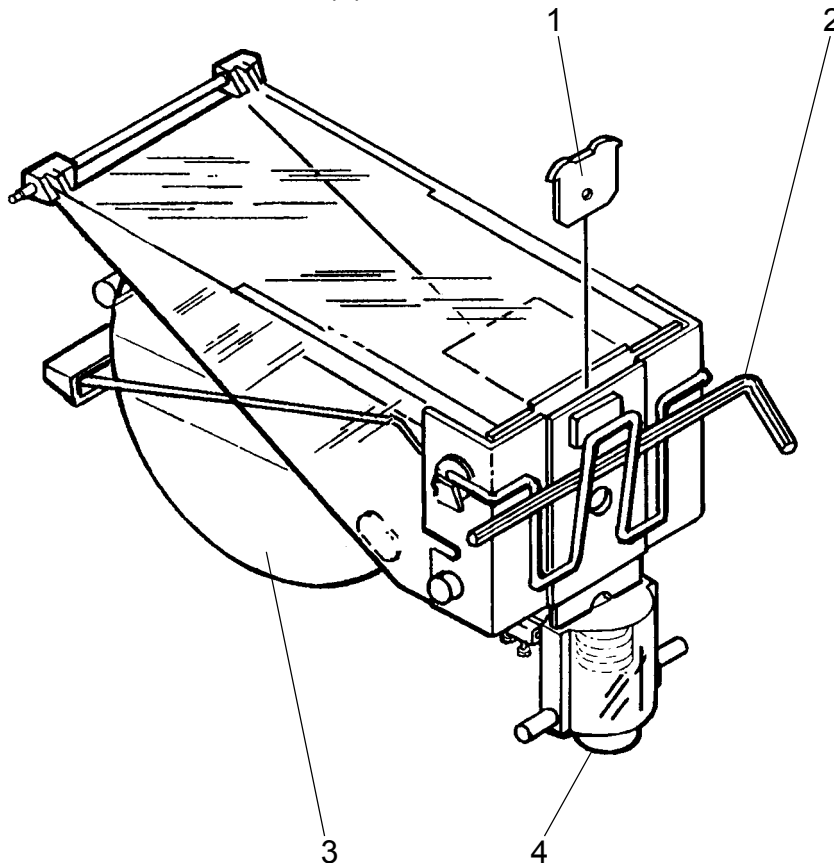

11. Reinstall the Stapler head only on the pivot pin side not in the plunger retraction swing arm (7).

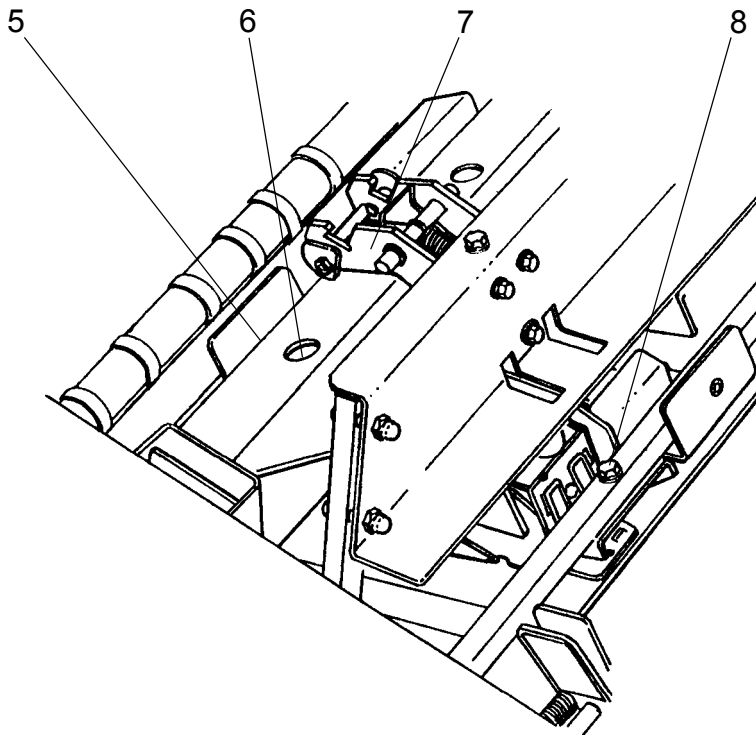

### ADJUSTMENT

1. Loosen the left (6) and the right (8) mounting screw.
2. Rotate the adjusting screw (5) counterclockwise as far as it will go without removing it.
3. Push down the Stapler head and move it by turning the adjustment screw (5) clockwise until the tool engages the slot in the anvil.
4. Tighten the left mounting screw (6).
5. Position the Stapler head so that the Alignment tool is centered (side to side) in the slot.
6. Tighten the right mounting screw (8).
7. Return the machine to operational condition.
8. Run a test set to verify the adjustment.

### PURPOSE

The purpose is to ensure that adequate pressure is applied to the Stapler heads when forming the staples.

1. Switch off the main power switch and disconnect the power cord.
2. Remove the Infeed cover according to REP 1.3.
3. Remove the Stapler head according to REP 3.1.
4. Rotate the motor linkage (3) to the down dead center.

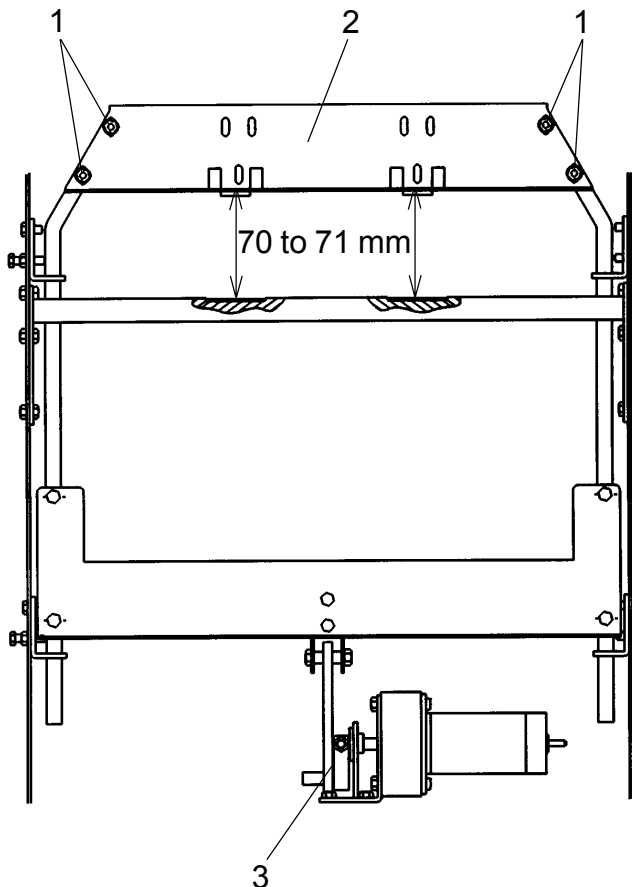

### ADJUSTMENT

1. Use a sliding caliper and check that the distance between the anvil and the upper side of the sheet plate is 70 mm to 71 mm.  
Check both front and rear side.
2. Loosen the four screws (1).
3. Move the upper stapler bar (2) to adjust.
4. Tighten the screws (1).
5. Check/Adjust the Stapler assembly drive bar position according to REP 3.4.

### PURPOSE

The purpose is to horizontally align the Stapled set drive rollers with the Idler wheels to ensure the correct set transportation into the fold area.

1. Adjust to the smallest sheet size on the control panel.
2. Ensure that the tires (3) are centered on the hubs (4) of the drive rollers.
3. Manually move the Drive rollers (2) up against the Pressure rollers (1) by pushing the Staple stop gate down.
4. Push down the staple stop gate and visually check that the Drive rollers are centered on the Pressure rollers.

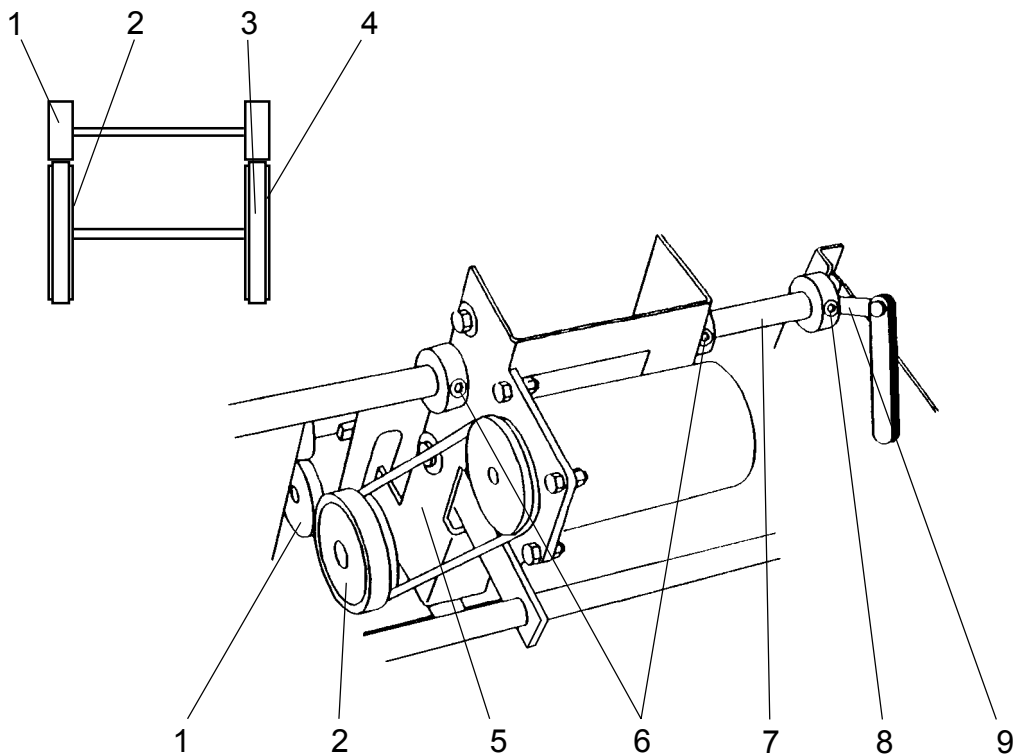

### ADJUSTMENT

1. Switch off the main power switch and disconnect the power cord.
2. Remove the Infeed cover according to REP 1.3.
3. Loosen the allen screw (8).
4. Move the shaft (7).
5. Insert a 0.3 mm feeler gauge (9) to ensure  $0.3 \pm 0.2$  mm endplay.  
**NOTE** The endplay 0.3 mm is to prevent the Staple stop gate shaft from binding.
6. Tighten the allen screw (8).
7. Loosen the two allen screws (6).
8. Move the assembly (5) so that the tires (3) are centered on the Pressure rollers (1).
9. Tighten the two allen screws (6).

### PURPOSE

The purpose is to position the Pressure rollers for the correct engagement with the Drive rollers.

1. Adjust to the largest sheet size on the Control panel.
2. Switch off the main power switch and disconnect the power cord.
3. Rotate the shield (2).

### VIEW OF STAPLED SET TRANSPORT AREA

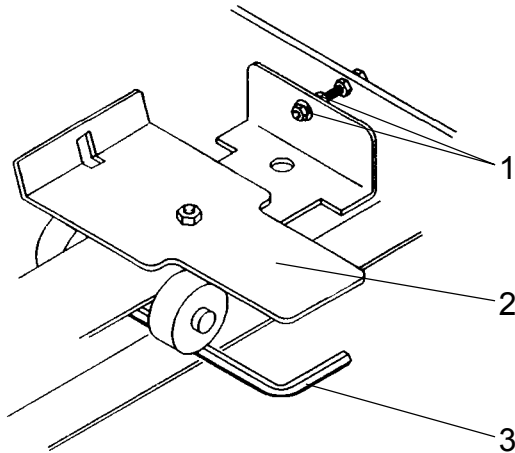

### ADJUSTMENT

1. Check that the gap (3) is 4 mm to 5 mm.

**NOTE:** Use a 4 mm allen wrench - as shown on drawing - to check that it fits in the gap and a 5 mm allen wrench to check that it does not fit in the gap.

2. Loosen one nut (1) and reposition the other (1) as required to obtain the gap.
3. Check/adjust the Stapled set transport solenoid according to REP 5.7.

### PURPOSE

The purpose is to ensure adequate engagement of the stapled set drive rollers.

1. Check/adjust the Pressure roller height according to REP 5.6.
2. Adjust to the smallest sheet size on the control panel.
3. Switch off the main power switch and disconnect the power cord.
4. Remove the infeed cover according to REP 1.3.

VIEW SHOWN WITH INFEED MODULE  
REMOVED FOR CLARITY

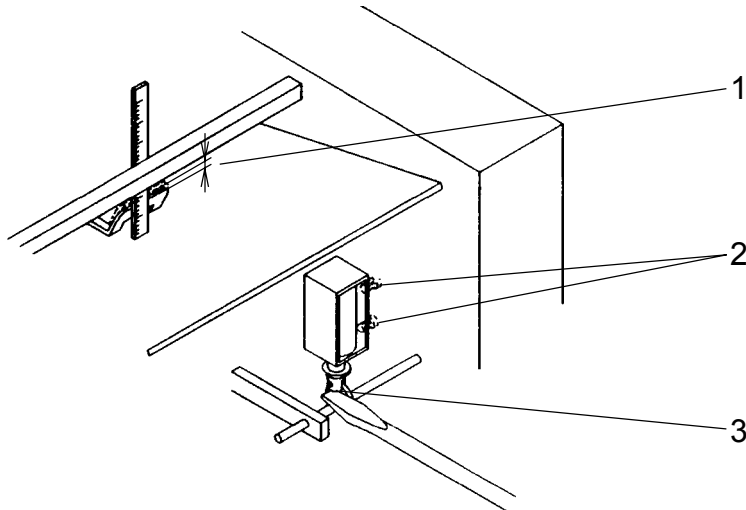

### ADJUSTMENT

1. Measure the height (1).
2. Push and hold the plunger (3) up.

**NOTE:** *Push on the plunger of the solenoid only, do not push on the linkage. If pushing on linkage the measurement will not be correct.*

3. Measure the height (1) again. The difference should be 0.5 mm to 1.0 mm
4. Loosen the two screws (2) and move the solenoid to obtain the dimension.
5. Tighten the screws.

### PURPOSE

The purpose is to transfer the original values from the Micro processor to the EEPROM. This procedure should be performed in response to minor logic problems such as failure in the operating sequence. Also perform this procedure if the controller PCB is replaced or if the power is lost during SDS.

### PROCEDURE

1. Switch of the main power switch.
2. Remove the rear cover according to REP 1.1.
3. Move DIP switch no. 1 on the controller PCB to the right (right when facing the PCB).
4. Switch on the main power switch.
  - The adjust LED on the control panel is flashing: The processor is transferring the default values to the EEPROM.
5. When the adjust LED stops flashing, switch off the main power switch.
6. Move DIP switch no. 1 on the controller PCB to the left (left when facing the PCB).
7. Reinstall the rear cover according to REP 1.1.

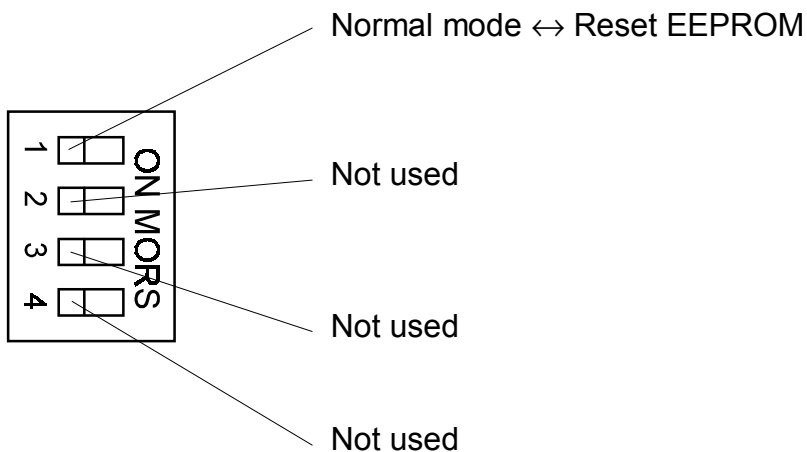

MOT 1	Stacker motor	PAGE 7.4.2
MOT 2	Stapled set transport motor	PAGE 7.4.3
MOT 3	Length adjustment motor	PAGE 7.4.2
MOT 4	Edge staple stop motor	PAGE 7.4.1
MOT 5	Back jogger motor	PAGE 7.4.4
MOT 6	Edge stapling transport motor	PAGE 7.4.4
MOT 7	Infeed transport belt motor	PAGE 7.4.4
MOT 8	Stapler motor	PAGE 7.4.3
MOT 9	Fold knife motor	PAGE 7.4.3
MOT 10	Folder rolls motor	PAGE 7.4.1, 7.4.3
MOT 11	Fold stop gate motor	PAGE 7.4.2
SOL 1	Stapled set transport solenoid	PAGE 7.4.3
SOL 2	Staple stop gate release solenoid	PAGE 7.4.3
SOL 3	Rear side guide release solenoid	PAGE 7.4.4
SW 1	Stapler home position switch	PAGE 7.4.3
SW 2	Fold knife home position switch	PAGE 7.4.2
SW 3	Length adjustment maximum limit switch	PAGE 7.4.1
SW 4	Length adjustment minimum limit switch	PAGE 7.4.1
SW 5	Interlock switch	PAGE 7.4.1
SW 6	Interlock bypass switch	PAGE 7.4.1
SW 7	Main power switch	PAGE 7.4.1, 7.4.3
SEN 1	Saddle stapling sensor	PAGE 7.4.4
SEN 2	Fold stop sensor	PAGE 7.4.2
SEN 3	Edge stapling sensor	PAGE 7.4.4
SEN 4	Outfeed sensor	PAGE 7.4.2
SEN 5	Infeed sensor	PAGE 7.4.4
F 1	Main power fuse	PAGE 7.4.3
F 2	10 VAC fuse	PAGE 7.4.3
F 3	10 VAC fuse for staple detection	PAGE 7.4.3
GFI	Ground fault interrupter	PAGE 7.4.3
T 1	Transformer	PAGE 7.4.3
REC 1	Rectifier	PAGE 7.4.1
FL 1	Filter	PAGE 7.4.1
C 1	Capacitor	PAGE 7.4.1
J 5	Interface receptacle	PAGE 7.4.3
J 6	Stacker receptacle	PAGE 7.4.1
PCB PL75-1	Controller Printed circuit board	PAGE 7.4.1

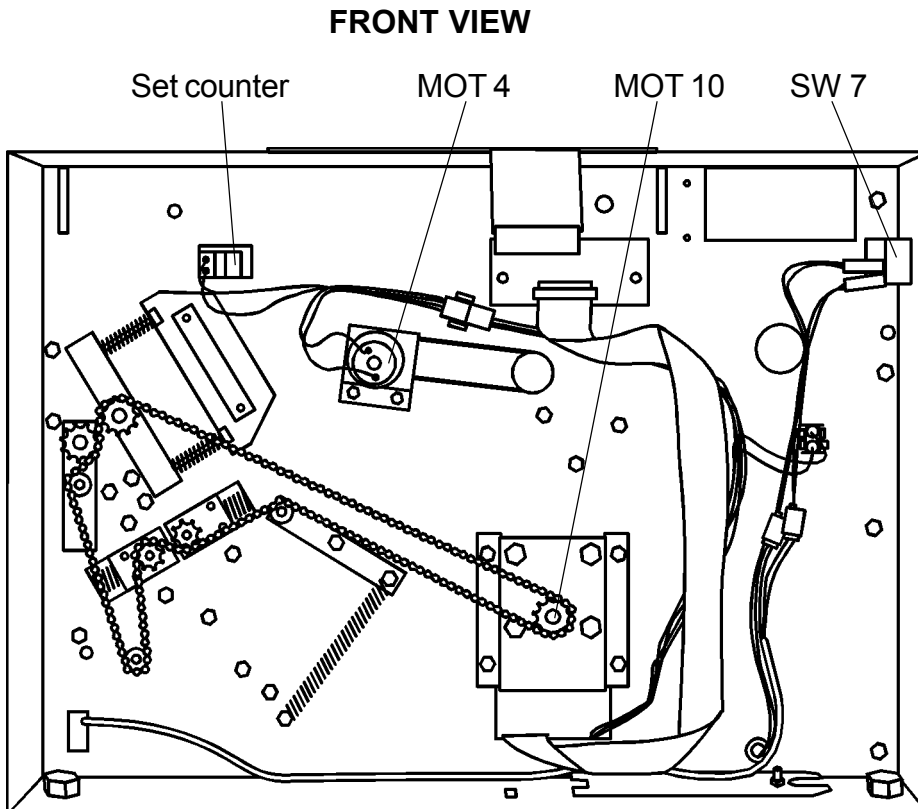
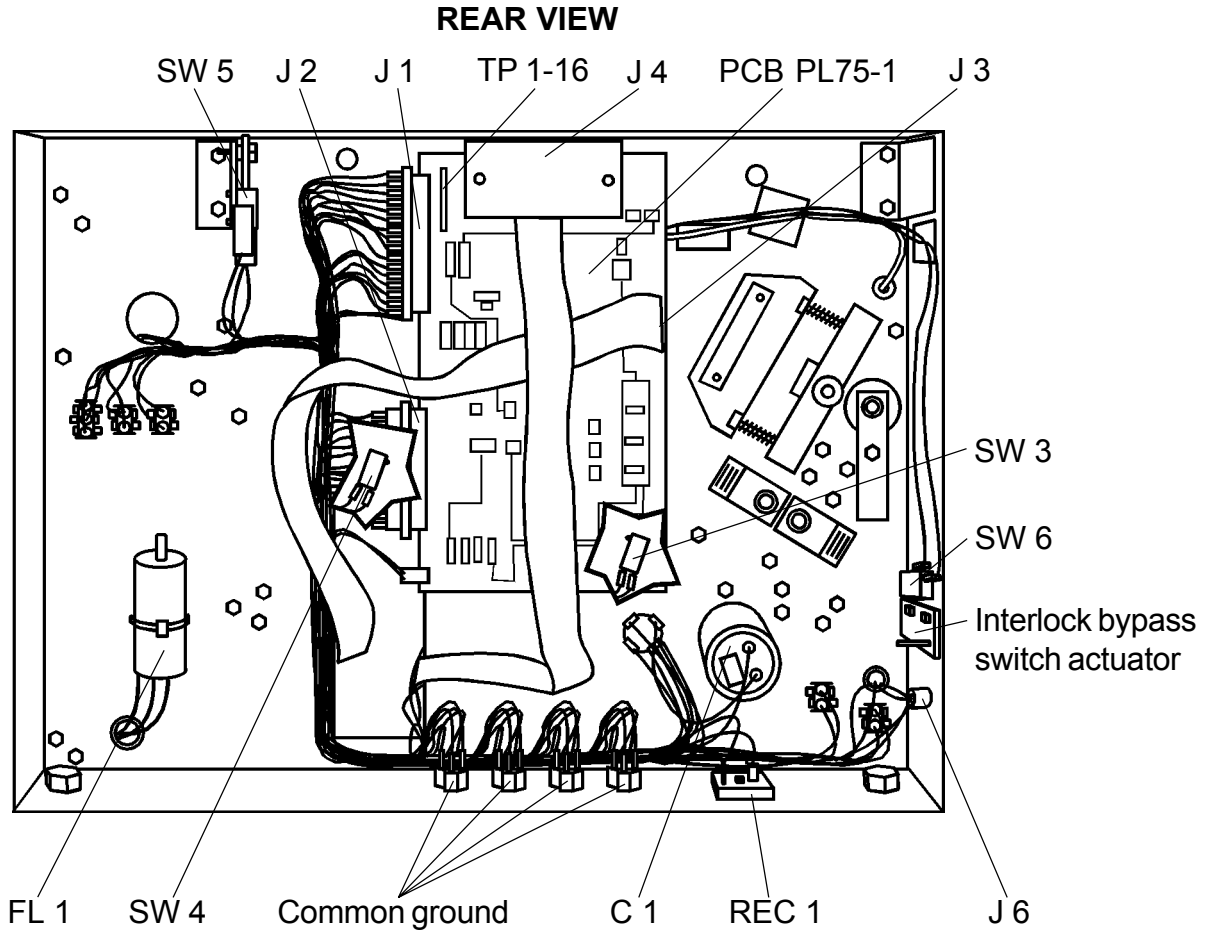

VIEW INSIDE OUTFEED COVER

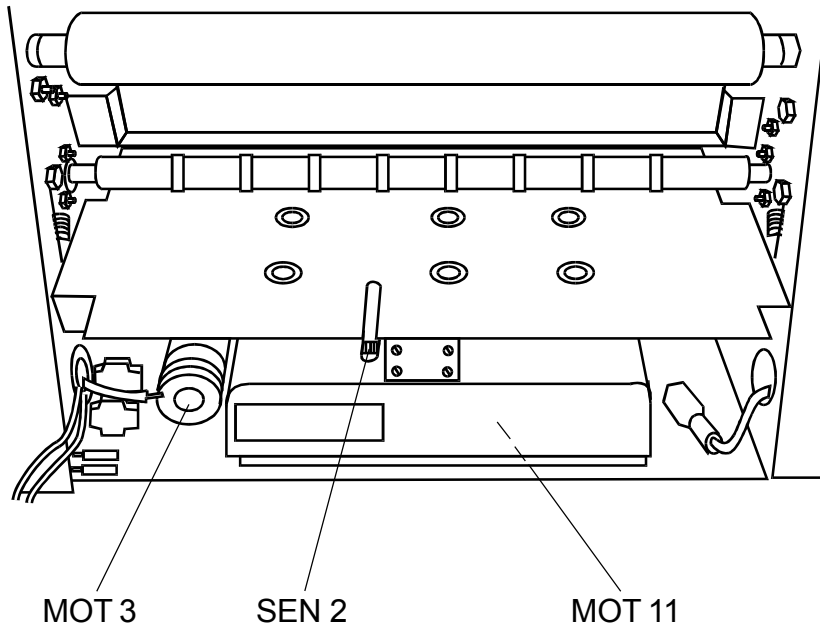

LEFT VIEW

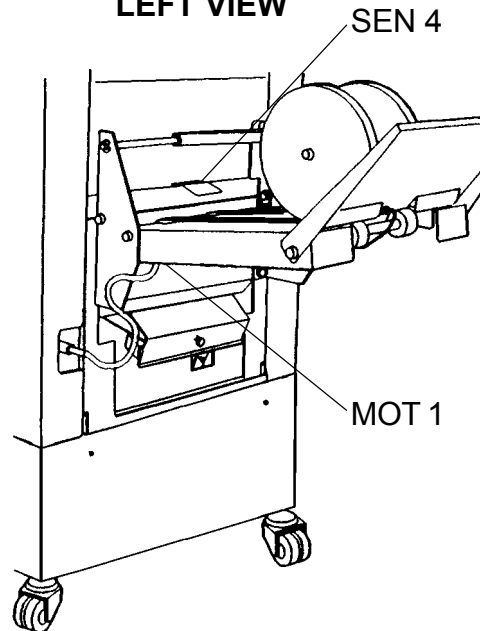

FOLD AREA SHOWN IN TIPPED POSITION

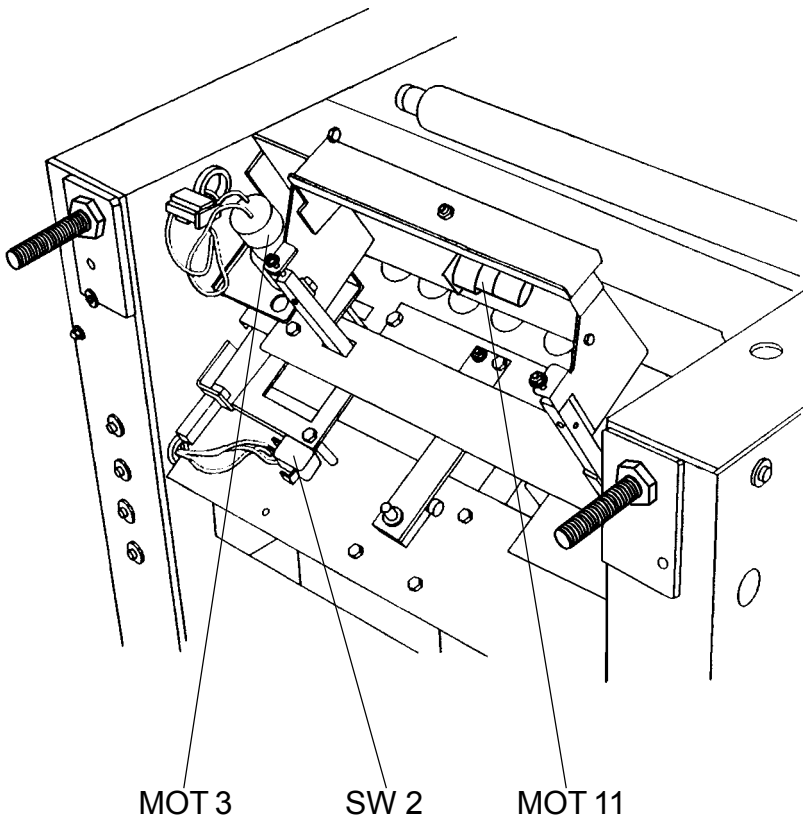

VIEW INSIDE INFEED COVER

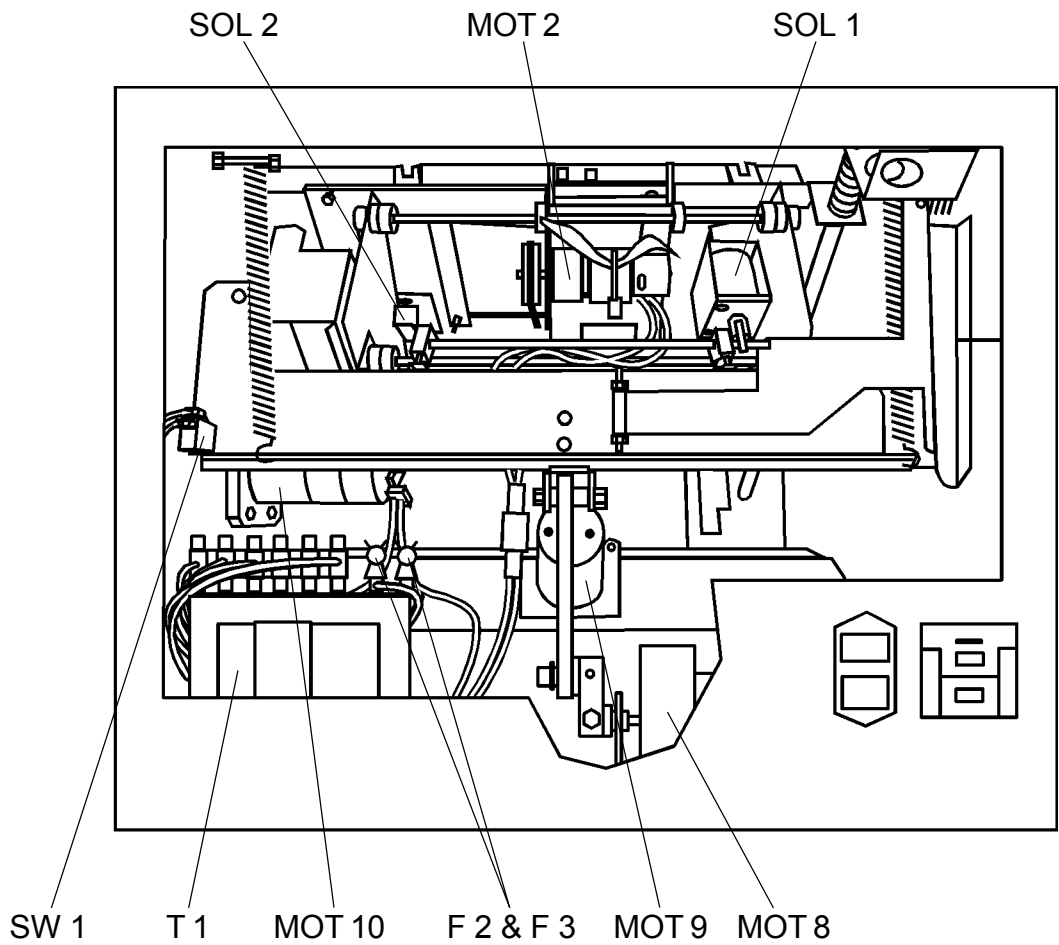

RIGHT VIEW INFEED COVER REMOVED

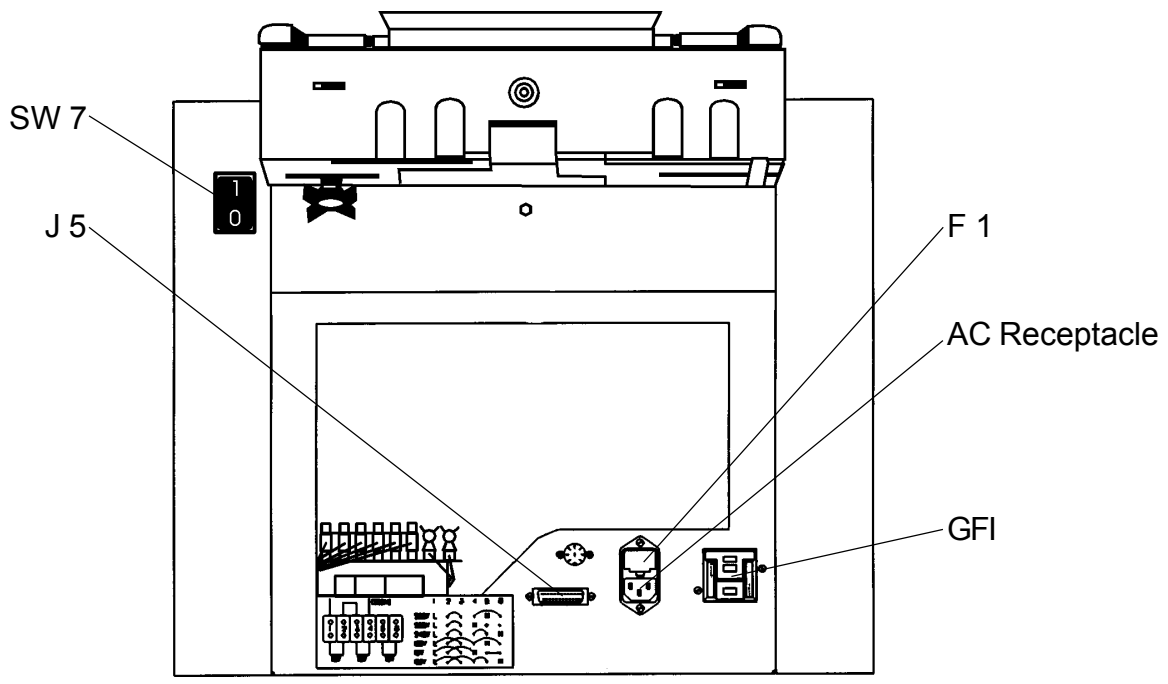

VIEW OF INFEED AREA

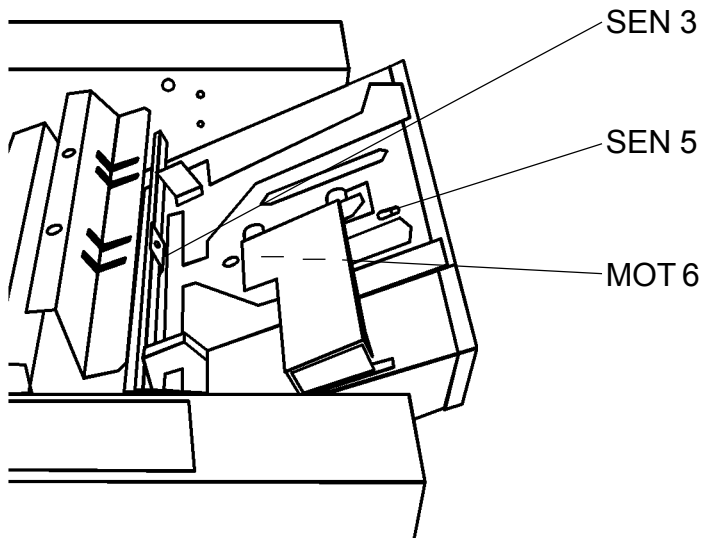

BOTTOM VIEW OF REMOVED INFEEDER

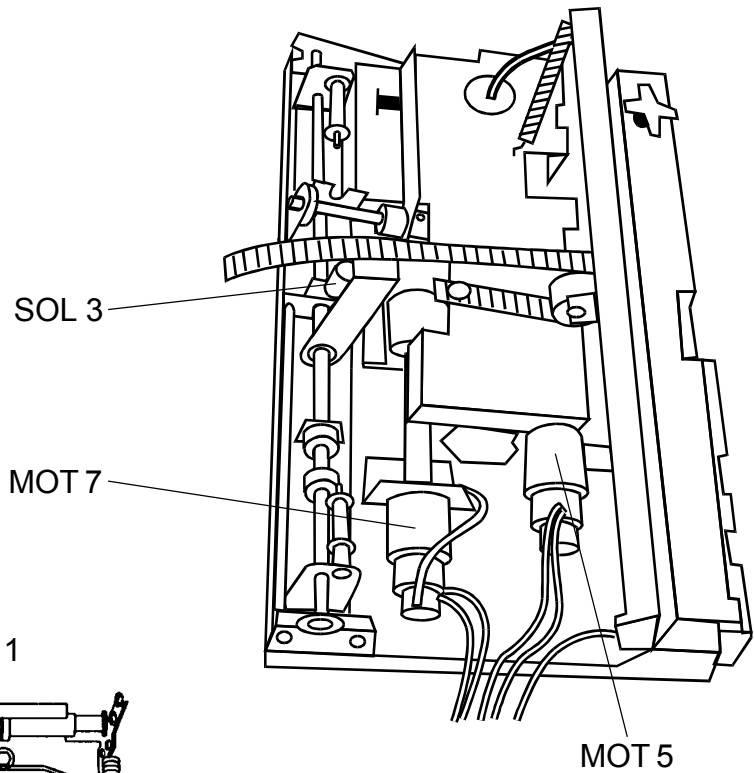

STAPLER AREA

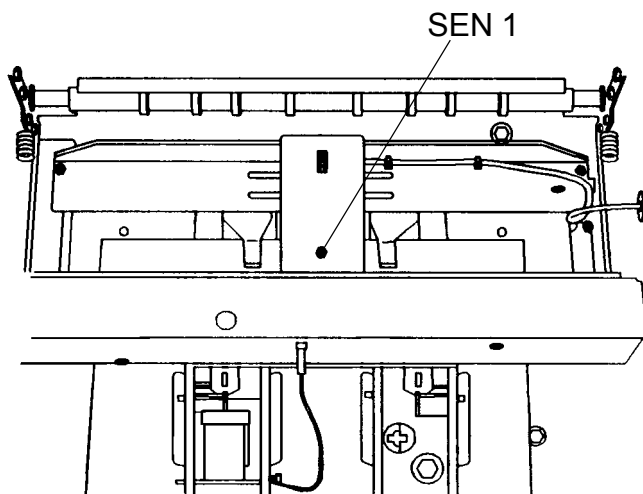

PAGE INTENTIONALLY BLANK

**PURPOSE**

The purpose of the Test points (see location on page 7.4.1, TP 1-16) is to use them as the (+) connector when adjusting sensors or when checking the function of some components and there wires. Use any common ground as (-) connector.

Voltage when low: Less than 0.9 VDC

Voltage when high: Greater than 2.2 VDC

<b>Test point</b>	<b>Description</b>	<b>Home position</b>
TP 1	Saddle stapling sensor SEN 1	Low inactivated
TP 2	Fold stop sensor SEN 2	Low inactivated
TP 3	Not used	
TP 4	Fold knife home position switch SW 2	Low activated
TP 5	Stapler home position switch SW 1	Low activated
TP 6	Jam signal from Trimmer	Low activated
TP 7	Edge stapling sensor SEN 3	High inactivated
TP 8	Outfeed sensor SEN 4	Low inactivated
TP 9	Infeed sensor SEN 5	Low inactivated
TP 10	Not used	
TP 11	Length adjustment maximum limit switch SW 3	High inactivated
TP 12	Not used	
TP 13	Length adjustment minimum limit switch SW 4	High inactivated
TP 14	Not used	
TP 15	Rear staple detection	High inactivated
TP 16	Front staple detection	High inactivated

### PURPOSE

The purpose of the Self diagnostic system control (SDS) is to provide a functional check of the components of the Model 75.

### PROCEDURE

**NOTE1:** *The Interlock switch or the Interlock bypass switch has to be actuated and the four DIP switches on the controller PCB has to be to the left (left when facing the PCB) and the Model 75 has to be cleared from paper sheets in order to perform the SDS.*

**NOTE2:** *If the SDS is repeated, switch off the power, wait a few seconds, switch on the power again to return the motors and solenoids to home position.*

**CAUTION1:** *Always handle the PCB and micro processor in accordance with electrostatic discharge procedures (ESD). The PCB contains components that are sensitive to ESD damage.*

**CAUTION2:** *Do not switch of the power during SDS. If there is a loss of power during SDS, reset the EEPROM according to PRG 6.1.*

1. Switch off the power.
2. Press and hold the Auto/Manual button. Switch on the power. Release the Auto/Manual button.
  - First the Auto LED is flashing: The Model 75 is testing the EE-prom.
  - Then the Manual LED is flashing: The Model 75 is testing the 24 voltage, the 32 voltage, motors and solenoids.
  - At last all of the LEDs are lighting on the control panel: The test is complete.
3. Press the five buttons on the control panel one at the time.
  - All of the LEDs should be switched off except the Staples LED.
4. Move the four DIP switches to the right (right when facing the PCB), then to the left.
  - The last LED on the control panel should be switched off.

If all of the LEDs are off, the SDS is complete, no errors found.

If any faults was detected during SDS, the last five LEDs will provide a fault code pattern. Press the Auto/Manual button to display any other faults that were detected during the SDS.

Refer to SDS Fault code table and locate the lighting pattern of the LEDs.

# FIP 8.1 Self diagnostic system control, Fault code table

T08039

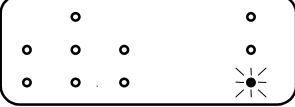
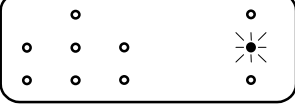
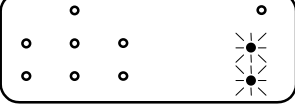
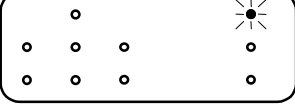
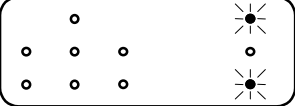
Fault code	Possible cause	Fault isolating / repair
<p><b>1. EEPROM error</b></p> 	<p>EEPROM values incorrect. EEPROM defective.</p>	<p>Reset the EE-prom according to PRG 6.1. Replace the controller PCB 75-1.</p>
<p><b>2. 32 VDC error</b></p> 	<p>Interlock switch SW 5 activated. Rectifier REC 1 defective. Transformer T 1 defective. Capacitor C 1 defective. Wires defective.</p>	<p>See fault code 5. Replace Rectifier. Replace Transformer. Replace Capacitor. Check the wires for an open circuit using a voltmeter. Measure from 20A and 20C on connector J2 to the capacitor.</p>
<p><b>3. 24 VDC error</b></p> 	<p>Controller PCB 75-1 defective. Controller PCB 75-1 defective.</p>	<p>Replace controller PCB. Replace controller PCB.</p>
<p><b>4. Interlock switch SW 5, activated.</b></p> 	<p>Top cover open or Interlock switch not activated. Top cover misadjusted. Micro switch defective.  Wires defective.</p>	<p>Close the Top cover or pull out the Interlock bypass switch actuator. Check/Adjust the Top cover according to REP 1.2. Disconnect the wires from the switch. Check the function of the switch using a voltmeter. Check both Interlock micro switch and Interlock bypass micro switch. Disconnect the wires from the switch. Check the wires for an open circuit using a voltmeter. Measure from 10C and 18A on connector J1 to the Interlock switch and 10C and 12A to the bypass switch.</p>
<p><b>5. Stapler home position switch SW 1, not activated.</b></p> 	<p>Stapler motor in faulty position. Stapler home position misadjusted. Micro switch defective.  Wires defective.  Controller PCB 75-1 defective.</p>	<p>Switch off the power and switch on the power again. Check/Adjust the Stapler home position according to REP 3.5. Disconnect the wires from the switch. Check the function of the switch using a voltmeter. Check that the voltage between TP5 on the controller PCB and common ground is less than 0.9 VDC when the switch is activated and greater than 2.2 VDC when the switch is inactivated. If checks above is good, replace the controller PCB.</p>

# Continue FIP 8.1 Self diagnostic system control, Fault code table T08039

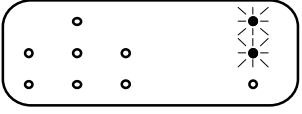
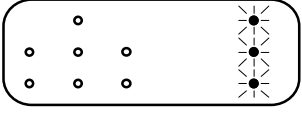
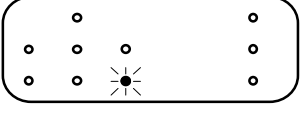
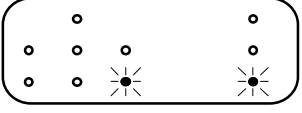
<u>Fault code</u>	<u>Possible cause</u>	<u>Fault isolating / repair</u>
<p><b>6. Fold knife motor home position switch SW 2, not activated.</b></p> 	<p>Fold knife motor in faulty position.</p> <p>Fold knife home position misadjusted.</p> <p>Micro switch defective.</p> <p>Wires defective.</p> <p>Controller PCB 75-1 defective.</p>	<p>Switch off the power and switch on the power again.</p> <p>Check/Adjust the Fold knife home position according to REP 4.4.</p> <p>Disconnect the wires from the switch. Check the function of the switch using a voltmeter.</p> <p>Check that the voltage between TP4 on the controller PCB and common ground is less than 0.9 VDC when the switch is activated and greater than 2.2 VDC when the switch is inactivated.</p> <p>If checks above is good, replace the controller PCB.</p>
<p><b>7. Fold stop gate motor MOT 11, open circuit.</b></p> 	<p>Motor defective.</p> <p>Wires defective.</p> <p>Controller PCB 75-1 defective.</p>	<p>Disconnect the motor connector. Check the motor for an open circuit using a voltmeter</p> <p>Disconnect the motor connector. Check the wires for an open circuit using a voltmeter. Measure from 1 and 3 on connector J4 to the motor connector.</p> <p>Replace the controller PCB.</p>
<p><b>8. Edge stapling sensor SEN 3, activated.</b></p> 	<p>Paper is blocking the sensor.</p> <p>Sensor defective.</p> <p>Wires defective.</p> <p>Controller PCB 75-1 defective.</p>	<p>Remove the paper.</p> <p>Check that the voltage between TP7 on the controller PCB and common ground is less than 0.9 VDC with the sensor blocked and greater than 2.2 VDC with the sensor unblocked.</p> <p>Disconnect the sensor connector. Check the wires for an open circuit using a voltmeter. Measure from 2C, 26A on connector J1 and common ground to the sensor connector.</p> <p>If checks above is good, replace the controller PCB.</p>
<p><b>9. Saddle stapling sensor SEN 1, activated.</b></p> 	<p>Paper is blocking the sensor.</p> <p>Sensor misadjusted.</p> <p>Sensor defective.</p> <p>Wires defective.</p> <p>Controller PCB 75-1 defective.</p>	<p>Remove the paper.</p> <p>Check/Adjust the Saddle stapling sensor according to REP 3.7.</p> <p>Check that the voltage between TP1 on the controller PCB and common ground is greater than 2.2 VDC with the sensor blocked and less than 0.9 VDC with the sensor unblocked.</p> <p>Disconnect the sensor connector. Check the wires for an open circuit using a voltmeter. Measure from 6A, 32A on connector J1 and common ground to the sensor connector.</p> <p>If checks above is good, replace the controller PCB.</p>

# Continue FIP 8.1 Self diagnostic system control, Fault code table T08039

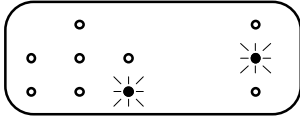
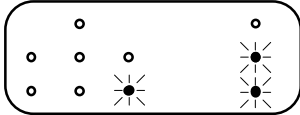
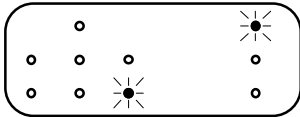
<u>Fault code</u>	<u>Possible cause</u>	<u>Fault isolating / repair</u>
<b>10. Outfeed sensor SEN 4, activated.</b> 	Paper is blocking the sensor. Sensor misadjusted. Sensor defective. Wires defective. Controller PCB 75-1 defective.	Remove the paper. Check/Adjust the Outfeed sensor according to REP 4.5. Check that the voltage between TP8 on the controller PCB and common ground is greater than 2.2 VDC with the sensor blocked and less than 0.9 VDC with the sensor unblocked. Disconnect the sensor connector. Check the wires for an open circuit using a voltmeter. Measure from 8A, 26C on connector J1 and common ground to the sensor connector. If checks above is good, replace the controller PCB.
<b>11. Fold stop sensor SEN 2, activated.</b> 	Paper is blocking the sensor. Sensor misadjusted. Sensor defective. Wires defective. Controller PCB 75-1 defective.	Remove the paper. Reposition the sensor to obtain the voltages below. Check that the voltage between TP2 on the controller PCB and common ground is greater than 2.2 VDC with the sensor blocked and less than 0.9 VDC with the sensor unblocked. Disconnect the sensor connector. Check the wires for an open circuit using a voltmeter. Measure from 4A, 32C on connector J1 and common ground to the sensor connector. If checks above is good, replace the controller PCB.
<b>12. Rear staple detection, activated.</b> 	Stapler head short circuit to chassis ground Wires defective. Controller PCB 75-1 defective.	Find what causes the short circuit and perform appropriate action. Check that the voltage between TP15 on the controller PCB and common ground is less than 0.9 VDC when the stapler head is in contact with the anvil and greater than 2.2 VDC when not in contact. Use a screw driver to connect the stapler head with the anvil. If check above is good, replace the controller PCB.

# Continue FIP 8.1 Self diagnostic system control, Fault code table <sup>T08039</sup>

**Fault code**

**Possible cause**

**Fault isolating / repair**

**13.Front staple detection, activated.**

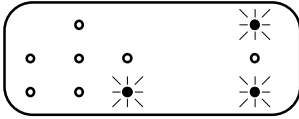

Stapler head short circuit to chassis ground.

Wires defective.

Controller PCB 75-1 defective.

Find what causes the short circuit and perform appropriate action.

Check that the voltage between TP16 on the controller PCB and common ground is less than 0.9 VDC when the stapler head is in contact with the anvil and greater than 2.2 VDC when not in contact. Use a screw driver to connect the stapler head with the anvil.

If check above is good, replace the controller PCB.

**14.Trimmer not connected.**

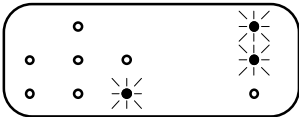

Model 75 intact.

Cabels not connected.

Wires defective.

Trimmer faulty.

Controller PCB 75-1 defective.

If a Trimmer is not connected.

Connect the Interface cable and the Power cord from the Trimmer to the Model 75.

Check the wires for an open circuit using a voltmeter. Measure from 20C on connector J1 to pin 3 on the DIN receptacle and pin 5 to common ground.

See technical documentation for Trimmer.

Replace the controller PCB.

**15.Infeed sensor SEN 5, activated.**

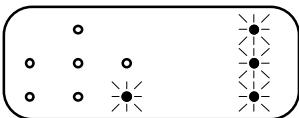

Paper is blocking the sensor.

Sensor misadjusted.

Sensor defective.

Wires defective.

Controller PCB 75-1 defective.

Remove the paper.

Reposition the sensor to obtain the voltages below.

Check that the voltage between TP9 on the controller PCB and common ground is greater than 2.2 VDC with the sensor blocked and less than 0.9 VDC with the sensor unblocked.

Disconnect the sensor connector. Check the wires for an open circuit using a voltmeter. Measure from 2A, 24A on connector J1 and common ground to the sensor connector.

If checks above is good, replace the controller PCB.

**16.Infeed transport belt motor MOT 7, open circuit.**

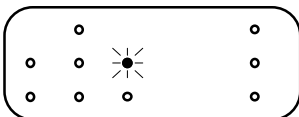

Motor defective.

Wires defective.

Controller PCB 75-1 defective.

Disconnect the motor connector. Check the motor for an open circuit using a voltmeter.

Disconnect the motor connector. Check the wires for an open circuit using a voltmeter. Measure from 16A and 16C on connector J2 to the motor connector.

Replace the controller PCB.

# Continue FIP 8.1 Self diagnostic system control, Fault code table <sup>T08039</sup>

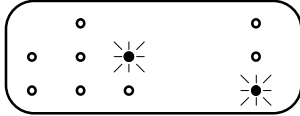
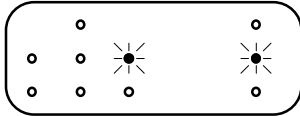
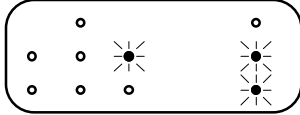
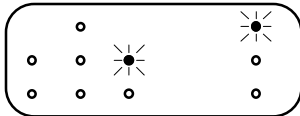
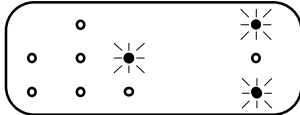
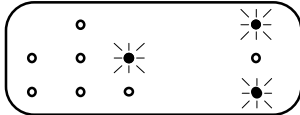
<b>Fault code</b>	<b>Possible cause</b>	<b>Fault isolating / repair</b>	
<b>17.Back jogger motor MOT 5, jogger up, open circuit.</b> 	Motor defective.	If both fault code 17 and 18 was detected. Disconnect the motor connector. Check the motor for an open circuit using a voltmeter.	
	Wires defective.	If both fault code 17 and 18 was detected. Disconnect the motor connector. Check the wires for an open circuit using a voltmeter. Measure from 14A and 12A on connector J2 to the motor connector.	
	Controller PCB 75-1 defective.	If only one of fault code 17 and 18 was detected. Replace the controller PCB.	
<b>18.Back jogger motor MOT 5, jogger down, open circuit.</b> 	Motor, Wires, Controller PCB	See fault code 17.	
	<b>19.Stapler motor MOT 8, open circuit.</b> 	Motor defective.	Disconnect the motor connector. Check the motor for an open circuit using a voltmeter.
		Wires defective.	Disconnect the motor connector. Check the wires for an open circuit using a voltmeter. Measure from 22A on connector J2 and common ground to the motor connector.
<b>20.Stapled set transport motor MOT 2, Open circuit</b> 	Controller PCB 75-1 defective.	Replace the controller PCB.	
	<b>21.Stapled set transport solenoid SOL 1, open circuit.</b> 	Motor defective.	Disconnect the motor connector. Check the motor for an open circuit using a voltmeter.
	Wires defective.	Disconnect the motor connector. Check the wires for an open circuit using a voltmeter. Measure from 6C on connector J2 and common ground to the motor connector.	
<b>21.Stapled set transport solenoid SOL 1, open circuit.</b> 	Solenoid defective.	Disconnect the solenoid connector. Check the solenoid for an open circuit using a voltmeter.	
	Wires defective.	Disconnect the solenoid connector. Check the wires for an open circuit using a voltmeter. Measure from 28C and +2C on connector J2 to the solenoid connector.	
	Controller PCB 75-1 defective.	Replace the controller PCB.	

# Continue FIP 8.1 Self diagnostic system control, Fault code table T08039

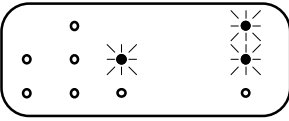
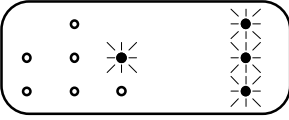
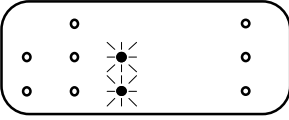
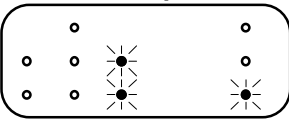
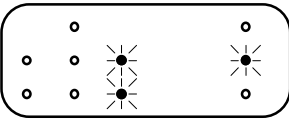
<b>Fault code</b>	<b>Possible cause</b>	<b>Fault isolating / repair</b>
<b>22. Staple stop gate release solenoid SOL 2, open circuit.</b> 	<p>Solenoid defective.</p> <p>Wires defective.</p> <p>Controller PCB 75-1 defective.</p>	<p>Disconnect the solenoid connector. Check the solenoid for an open circuit using a voltmeter.</p> <p>Disconnect the solenoid connector. Check the wires for an open circuit using a voltmeter. Measure from 26C and +24A on connector J2 to the solenoid connector.</p> <p>Replace the controller PCB.</p>
<b>23. Rear side guide release solenoid SOL 3, open circuit.</b> 	<p>Solenoid defective.</p> <p>Wires defective.</p> <p>Controller PCB 75-1 defective.</p>	<p>Disconnect the solenoid connector. Check the solenoid for an open circuit using a voltmeter.</p> <p>Disconnect the solenoid connector. Check the wires for an open circuit using a voltmeter. Measure from 26A and +24C on connector J2 to the solenoid connector.</p> <p>Replace the controller PCB.</p>
<b>24. Fold knife motor MOT 9, open circuit.</b> 	<p>Motor defective.</p> <p>Wires defective.</p> <p>Controller PCB 75-1 defective.</p>	<p>Disconnect the motor connector. Check the motor for an open circuit using a voltmeter.</p> <p>Disconnect the motor connector. Check the wires for an open circuit using a voltmeter. Measure from 22C on connector J2 and common ground to the motor connector.</p> <p>Replace the controller PCB.</p>
<b>25. Folder rolls motor MOT 10, open circuit.</b> 	<p>Motor defective.</p> <p>Wires defective.</p> <p>Controller PCB 75-1 defective.</p>	<p>Disconnect the motor connector. Check the motor for an open circuit using a voltmeter.</p> <p>Disconnect the motor connector. Check the wires for an open circuit using a voltmeter. Measure from 28A on connector J2 and common ground to the motor connector.</p> <p>Replace the controller PCB.</p>
<b>26. Stacker motor MOT 1, open circuit.</b> 	<p>Motor defective.</p> <p>Wires defective.</p> <p>Controller PCB 75-1 defective.</p>	<p>Disconnect the motor connector. Check the motor for an open circuit using a voltmeter.</p> <p>Disconnect the motor connector. Check the wires for an open circuit using a voltmeter. Measure from 6A on connector J2 and common ground to the motor connector.</p> <p>Replace the controller PCB.</p>

## Continue FIP 8.1 Self diagnostic system control, Fault code table <sup>T08039</sup>

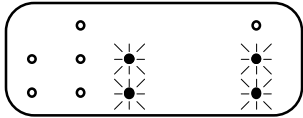
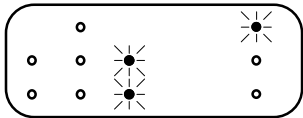
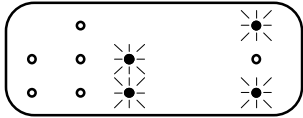
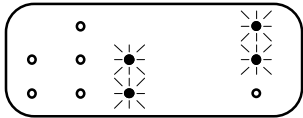
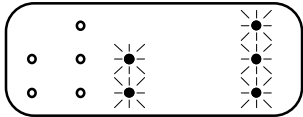
<b>Fault code</b>	<b>Possible cause</b>	<b>Fault isolating / repair</b>
<b>27.Length adjustment maximum limit switch SW 3, activated.</b> 	<p>Adjusted to maximum paper size.</p> <p>Micro switch defective.</p> <p>Wires defective.</p> <p>Controller PCB 75-1 defective.</p>	<p>Adjust to a smaller paper size. It is allowed to run the Model 75 adjusted to the largest paper size</p> <p>Disconnect the wires from the switch. Check the function of the switch using a voltmeter.</p> <p>Check that the voltage between TP11 on the controller PCB and common ground is less than 0.9 VDC when the switch is activated and greater than 2.2 VDC when the switch is inactivated.</p> <p>If checks above is good, replace the controller PCB.</p>
<b>28.Length adjustment minimum limit switch SW 4, activated.</b> 	<p>Adjusted to minimum paper size.</p> <p>Micro switch defective.</p> <p>Wires defective.</p> <p>Controller PCB 75-1 defective.</p>	<p>Adjust to a larger paper size. It is allowed to run the Model 75 adjusted to the smallest paper size</p> <p>Disconnect the wires from the switch. Check the function of the switch using a voltmeter.</p> <p>Check that the voltage between TP13 on the controller PCB and common ground is less than 0.9 VDC when the switch is activated and greater than 2.2 VDC when the switch is inactivated.</p> <p>If checks above is good, replace the controller PCB.</p>
<b>29.Edge staple stop motor MOT 4, open circuit.</b> 	<p>Motor defective.</p> <p>Wires defective.</p> <p>Controller PCB 75-1 defective.</p>	<p>Disconnect the motor connector. Check the motor for an open circuit using a voltmeter.</p> <p>Disconnect the motor connector. Check the wires for an open circuit using a voltmeter. Measure from 10A and 10C on connector J2 to the motor connector.</p> <p>Replace the controller PCB.</p>
<b>30.Edge stapling transport motor MOT 6, open circuit</b> 	<p>Motor defective.</p> <p>Wires defective.</p> <p>Controller PCB 75-1 defective.</p>	<p>Disconnect the motor connector. Check the motor for an open circuit using a voltmeter.</p> <p>Disconnect the motor connector. Check the wires for an open circuit using a voltmeter. Measure from 12C and 14C on connector J2 to the motor connector.</p> <p>Replace the controller PCB.</p>
<b>31.Length adjustment motor MOT 3, open circuit.</b> 	<p>Motor defective.</p> <p>Wires defective.</p> <p>Controller PCB 75-1 defective.</p>	<p>Disconnect the motor connector. Check the motor for an open circuit using a voltmeter.</p> <p>Disconnect the motor connector. Check the wires for an open circuit using a voltmeter. Measure from 8A and 8C on connector J2 to the motor connector.</p> <p>Replace the controller PCB.</p>

PAGE INTENTIONALLY BLANK