

SERIAL NO-

MODEL-

SAFETY ALERT

This safety alert symbol means CAUTION OR WARNING-PERSONAL SAFETY INSTRUCTION. Personal injury may result if safety precautions are not carefully read before attempting to operate or repair this machine. See SAFETY PRECAUTIONS, page 4.

- This machine is designed for **ONE PERSON OPERATION ONLY!**
- Always **DISCONNECT THE POWER** before working on this machine.
- **DO NOT OPERATE WITH ANY GUARDS REMOVED!** Replace all guards before operating.
- **CRUSH HAZARD** - Keep hands, hair, cleaning rags, & loose clothing away from drills.

Instruction and Parts Manual



MODEL MS-5 Paper Drilling Machine

This manual covers serial numbers 965600 & up.
ALWAYS GIVE THE SERIAL NUMBER OF YOUR MACHINE WHEN WRITING.

Sold and serviced by

THE CHALLENGE MACHINERY COMPANY

1433 Fulton Avenue/Grand Haven, Michigan 49417-1594 U.S.A.
Phone: 616/842-8300 - Fax: 616/842-6511 - www.challengemachinery.com

F.300-B

INTRODUCTION

WELCOME to the family of Challenge® users. Challenge has been developing and manufacturing Graphics Arts Equipment for over 100 years and is today one of the world's leading producers and distributors of Paper Cutters, Paper Drills and Bindery Equipment.

THE CHALLENGE REPUTATION is important to you as a user for the continuous, ready availability of parts and service.

THIS MANUAL is designed to help you get the most from your Challenge equipment. Keep this manual in a safe, convenient place for quick reference by operators and service personnel.



SAFETY ALERT! This symbol means **CAUTION OR WARNING: Personal safety instructions!** Pay special attention to the instructions in bold type. Personal injury may result if the precautions are not read and followed.

READ THIS MANUAL BEFORE OPERATING! Follow precautions and instructions given and you should have years of trouble-free operation. If after reading the manual questions still remain, contact your Authorized Challenge Dealer or the Challenge Service Department. For the dealer nearest you or for service questions call (616)-842-8300.

FOR PARTS AND SERVICE contact the Authorized Challenge Dealer from whom you purchased your machine. Use the illustrations and parts lists at the back of this manual to identify the correct parts needed. **Always give the SERIAL NUMBER and MODEL** of your machine to insure that the correct parts are sent as soon as possible.

Take a few minutes right now to **RECORD YOUR MACHINE SERIAL NUMBER** in the space provided on the front cover of this manual. Also be sure to fill out the warranty card accompanying this manual and return it **DIRECT TO CHALLENGE**.

If you bought a used machine, it is important to have the following information on record at Challenge. Copy this page, fill in the information and send it care of: The Challenge Service Department, 1433 Fulton Avenue, Grand Haven, MI 49417-1594. Fax (616) 842-6511. Phone (616) 842-8300.

CHALLENGE MODEL	SERIAL NUMBER	
ATTN	COMPANY	
ADDRESS		
CITY	STATE	ZIP
PHONE	DATE INSTALLED	
DEALER'S NAME AND CITY		

WARRANTY INFORMATION

PLEASE REVIEW THE ENCLOSED WARRANTY SHEET!

*It is **very important** that you read and understand the conditions outlined in the Warranty Information Sheet included with the manual information package.*

*The Warranty Information Sheet must be filled out completely, returned, and be **ON-FILE** at **THE CHALLENGE MACHINERY COMPANY** in order for the warranty to be issued for this machine.*

Challenge® is a registered trademark of The Challenge Machinery Company. 1433 Fulton Street, Grand Haven, MI 49417.
Copyright © 1996 by The Challenge Machinery Company. All rights reserved. Printed in the U.S.A.

F.300-B/MS-5 DRILL/JUN 97

TABLE OF CONTENTS

INTRODUCTION	2
SAFETY PRECAUTIONS	4
CAUTION: POWER LOCK-OUT PROCEDURE	4
PACKING LIST	5
SPECIFICATIONS	5
WARNING LABEL DEFINITIONS	6
INSTALLATION	7
Unpacking	7
Power Hookup	7
SETUP INSTRUCTIONS	7
Starting the Machine	7
Safety Interlock System	8
Hydraulic Check	8
Positioning Drill Heads	8
Drive Belt Adjustment	9
Drill Installation	9
Drill Removal	9
Stroke Adjustment (Table Height Adjustment)	9
Adjusting the Stroke Speed	9
Setting Up the Backgagè	10
Using the Side Guide(s)	10
Drill Blocks	10
Emptying the Drill Chips	10
OPERATION	10
DRILLING TIPS	11
ACCESSORIES FOR CHALLENGE PAPER DRILLING MACHINES	12

TECHNICAL SECTION FOR TRAINED PERSONNEL ONLY

TROUBLESHOOTING	16
ROUTINE MAINTENANCE	17
SERVICE CHECKLIST	17
NOTES	19
MAIN ASSEMBLY - FRONT VIEW	20
MAIN ASSEMBLY - SIDE VIEW	22
MAIN ASSEMBLY - TOP VIEW	26
MAIN ASSEMBLY - DRILL GUARD (50 HZ ONLY)	27
BELT INSTALLATION	29
HYDRAULIC POWER UNIT ASSEMBLY	30
HYDRAULIC SEQUENCE OF OPERATION	31
BASIC MACHINE SCHEMATIC	32
ELECTRICAL SEQUENCE OF OPERATION	33
POWER PANEL ASSEMBLY 1PH 208/230 V, 50/60 HZ	34
POWER PANEL ASSEMBLY 3PH 208/230 V, 60 HZ	36
POWER PANEL ASSEMBLY 3PH 380/415 V, 50 HZ	38
DRILL HEAD ASSEMBLY	40
POWER PANEL LABEL	41
TWO HAND CONTROL OPTION	42
DRILL GUARD KIT	44
BELT GUARD SWITCH REPLACEMENT KIT	45
DRILL GUARD SWITCH REPLACEMENT KIT	46
SAFETY SYSTEM TESTS	47

SAFETY PRECAUTIONS



This safety symbol means **CAUTION/WARNING - PERSONAL SAFETY INSTRUCTION**. Read the instructions because it has to do with safety. Failure to comply with the following instructions may result in personal injury.

- This machine is designed and safeguarded for **ONE PERSON** operation. **NEVER** operate the machine with more than one person.
- Safety of this machine is the responsibility of the user and operator. Use good judgement and common sense when working with and around this machine.
- **READ** and understand all instructions thoroughly before using the machine. If questions still remain, call your Authorized Challenge Dealer - Failure to understand operating instructions may result in personal injury.
- Only trained and authorized persons should operate the machine.
- **DO NOT ALTER SAFETY GUARDS OR DEVICES**, they are for your protection and should not be altered or removed. Severe lacerations could result.
- **DISCONNECT POWER** before cleaning, lubricating, servicing, or making adjustments not requiring power. Lock the disconnect switch in the **OFF** position, see Power Lockout Procedure below.
- **HIGH SPEED DRILL** - Keep rags, loose clothing and long hair away from rotating drill. Personal injury could result from items being caught on drill.
- Have your electrician make sure the machine is properly grounded, see Power Hookup, page 7.
- Have your electrician check for sufficient power to operate the machine properly, see page 7.
- **OBSERVE ALL CAUTION PLATES AND LABELS** on this machine.
- **KEEP FOREIGN OBJECTS** off table and away from drill.
- **BE EXTREMELY CAREFUL** when handling and changing the drills. Severe lacerations or dismemberment could result from careless handling procedure.
- **KEEP THE FLOOR** around the machine free of trim, debris, oil and grease.
- When replacing hydraulic parts, loosen the connections slowly to release pressure. Never loosen connections with the machine running.
- If the machine sounds or operates abnormally, turn it off and consult the Trouble Shooting section of this manual. If the problem cannot be corrected, have it checked by a qualified service person or your Authorized Challenge Dealer.
- **CRUSH HAZARD**, keep feet off the pedal when handling paper under the clamp. **DO NOT REST FOOT ON PEDAL** at any time!
- **DO NOT REACH UNDER THE DRILL AND CLAMP AREA!**
- **DO NOT OPERATE WITH ANY GUARDS REMOVED!** Replace all guards after adjusting, lubricating or servicing the machine.
- **SEVERE LACERATIONS** - Contact with high speed drill could cause severe injury. Always turn machine off and wait for drill to stop before removing drill bits. Keep hands away from drill(s) when operating.

CAUTION: POWER LOCK-OUT PROCEDURE

For maximum safety when making adjustments or repairs to your machine, be sure to lock out the main power control switch to which the machine is connected. The switch should be thrown to the **OFF** position and a padlock placed in the loop. The key should be held by the person servicing the machine.

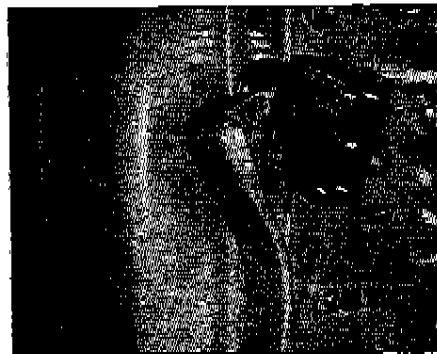

(fig. 1)

PACKING LIST

Part No.	Description	Qty.
	Basic Machine	1
W-105-1	Allen Wrench, 1/4" 'T' Handle	1
A-6588	Wrench, 'T' Handle Drill Drift	1
4688	Lubrication Stick, Drill Ease	1
A-4950	Drill Sharpener, Hand	1
6564	Drill Block	3
45067	Backgage Filler Block Asm. (magnetic)	2
45163	Spring - Drill Block	1
8278-1	Knob	2
Drill Head(s)-as ordered Includes as Standard		(per head)
CD-4-2 1/2	1/4" (64mm) Hollow Drill	1
K-85	Drift Hole Cover	1

SPECIFICATIONS

Drilling

Number of Drill Heads	2 to 5
Drill Bit Sizes Available	1/8" to 1/2" (3 mm to 13 mm)
Center To Center Maximum	15" (38 cm)
Minimum Center Distance Between Heads	1 7/8" (8.7 cm)
Maximum Drilling Capacity (Pile Height)	2 1/2" (63 mm)
Strokes per Minute (Adjustable)	Up to 18
Backgage Adjustment	0 to 5" (0 to 13 cm)
Vertical Adjustment of Individual Heads	1/4" (6mm)

Dimensions

Table	17 3/4" x 34" (45 cm x 86.4 cm)
Table Height	37" (94 cm)
Overall Height	56" (142 cm)
Floor Space Needed	36" x 36" (92 cm x 92 cm)
Net Weight (Approximate)	830 lbs (373.5 kg)
Shipping Weight (Approximate)	1000 lbs (453.6 kg)

Electrical

208/230 Volts ($\pm 10\%$)/18 Amps, 1 Phase, 60 Hz, AC. Service size 30 Amps.

Pump: 1/2 H.P. Spindle: 1 1/2 H.P.

Optional Motor: 208/230 Volts ($\pm 10\%$)/10 Amps, 3 Phase, AC. Service size 20 Amps.

460 Volts ($\pm 10\%$)/5 Amps, 3 Phase, AC. Service size 15 Amps.

Sound Emission

A-weighted sound pressure level measured in an enclosed room at 6 feet (183 cm) above floor:

Machine running: Less than 70 dB

Machine drilling paper: 71 dB

Challenge reserves the right to make changes to any product or specification without notice and without incurring responsibility to existing units.

WARNING LABEL DEFINITIONS

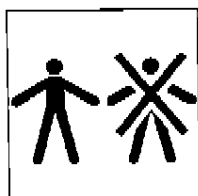

SINGLE OPERATOR

Do not operate with more than one person.



SHOCK HAZARD

Disconnect power before removing cover. Replace cover before operation.



SHOCK HAZARD

Disconnect power before removing cover. Replace cover before operation.

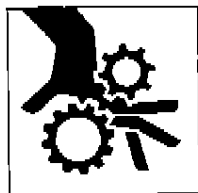

HAZARDOUS AREA

Disconnect power before cleaning, servicing, or making adjustments not requiring power. Do not alter safety guards or devices, they are for your protection. Replace all guards, do not operate with any guards removed.

INSTALLATION

NOTE: All guards and instruction plates are installed for your safety and information and must remain on the machine as shipped from the factory.

Unpacking

Unless otherwise specified, this machine is packaged completely assembled. The drill head(s) specified on the order are shipped already installed. The machine should be unpacked carefully by removing the packaging materials without damaging any of the machine parts.

Immediately after uncrating, check off parts received against the packing list. Also, examine for any physical signs of damage incurred during shipment. The machine is inspected before and after crating at our plant. The responsibility for filing a claim against the carrier for damages incurred during shipment rests with the receiver of the goods (FOB our factory).

The machine is held in place on its shipping skid with plastic strapping material. The machine weighs approximately 850 lbs. (380 kg.), so be sure you have sufficient equipment and manpower to handle the machine safely. Contact your Authorized Challenge Dealer to arrange for installation.

Remove the protective coating of light oil from the machined surfaces with a cleaning solvent, such as type wash. Clean all other surfaces with a solvent such as C.R.C.

Power Hookup



WARNING: DISCONNECT POWER before cleaning, lubricating, servicing, or making adjustments not requiring power. Lock the disconnect switch in the OFF position (see Power Lockout Procedure, pg. 4).

The machine is factory wired to the customer's specification. It is the customer's responsibility to wire the motor for the current and voltage specified on the name plate. It is important that the line voltage specified be maintained. Failure to do so will result in improper operation of the machine (see trouble shooting section for specific problems). It may be necessary to provide a dedicated line for the machine.

The standard motor for this machine is a 208/230 single phase. This machine should be on a 30 amp circuit

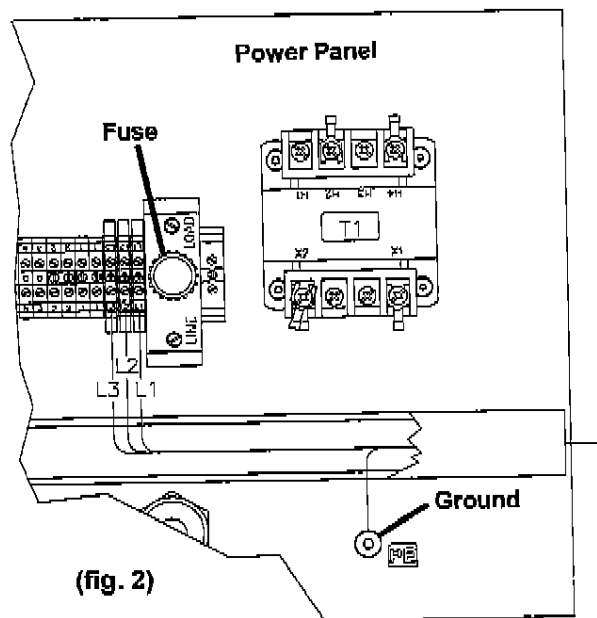

and wired with #10 gauge wire. Optional three phase motors are available also; 230/208 three phase, 20 amp circuit, #12 GA. wire; and 460 volt three phase, 15 amp circuit, with #14 GA. wire.

Remove the lower front cover. Remove the knockout plug on the right side of the machine. Route the power cord through the knockout hole and secure using a conduit connector. Connect wire leads to terminals as shown in fig 2 (single phase use L1 and L2 only). Connect the ground lead to the power panel as shown. Replace the front cover.

On three phase machines, check to see that the motor turns in the proper direction. Briefly turn the machine on and off then look at the belt. If it turns in the opposite direction of the arrow on top of the motor, disconnect power to the machine and switch the connection of any one wire with another. Check the rotation of the motor again to be sure it turns in the proper direction.

SETUP INSTRUCTIONS

Starting the Machine

The power for this machine is supplied by two motors; one is for the hydraulic power pack and the other is for the spindle. The hydraulic motor drives the pump directly while the spindle motor drives the drill heads. The two motors are started and stopped simultaneously by "on" and "off" push-buttons located on the control panel (the main disconnect switch must be in the "on" position, see fig. 3). The on button has a collar guard to reduce the possibility of accidental contact. Be sure both motors are operating before trying to drill paper.

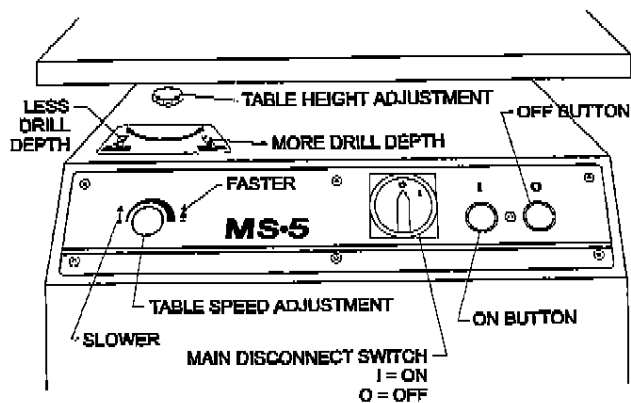

(fig. 3)

Safety Interlock System

The MS-5 paper drill is equipped with a safety interlock system which prevents the machine from being started with the front cover open or the optional drill guard removed. If the cover is opened or the guard removed when the drill is in operation, the motors will shut off and must be restarted when the cover and guard are back in place. This is a safety feature provided to prevent accidental contact with moving parts and must not be tampered with.

Hydraulic Check

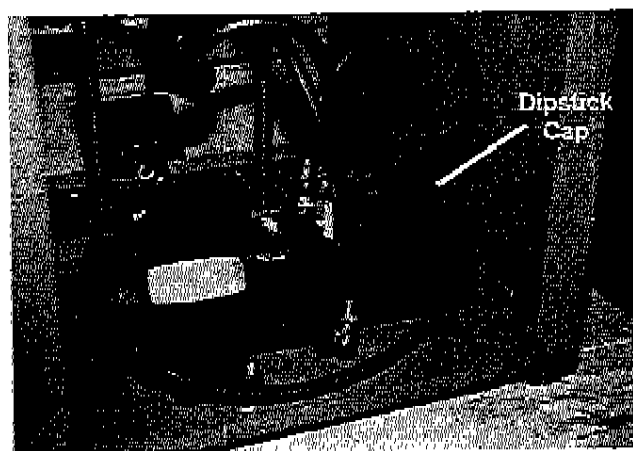

(fig. 4)

Check the hydraulic oil supply for the proper level. This check is made by removing the rear panel and unscrewing the dip stick located on the hydraulic tank (fig. 4). The oil level should be no higher than $\frac{1}{2}$ " (13 mm) up from the bottom of the dip stick to allow room for expansion of the oil when running. Recommended oils and a cross-reference chart are found in the maintenance section of this manual.

Positioning Drill Heads

Drill heads ordered with your machine have been installed at the factory. One $\frac{1}{4}$ " drill is supplied as standard equipment with each head unless otherwise speci-

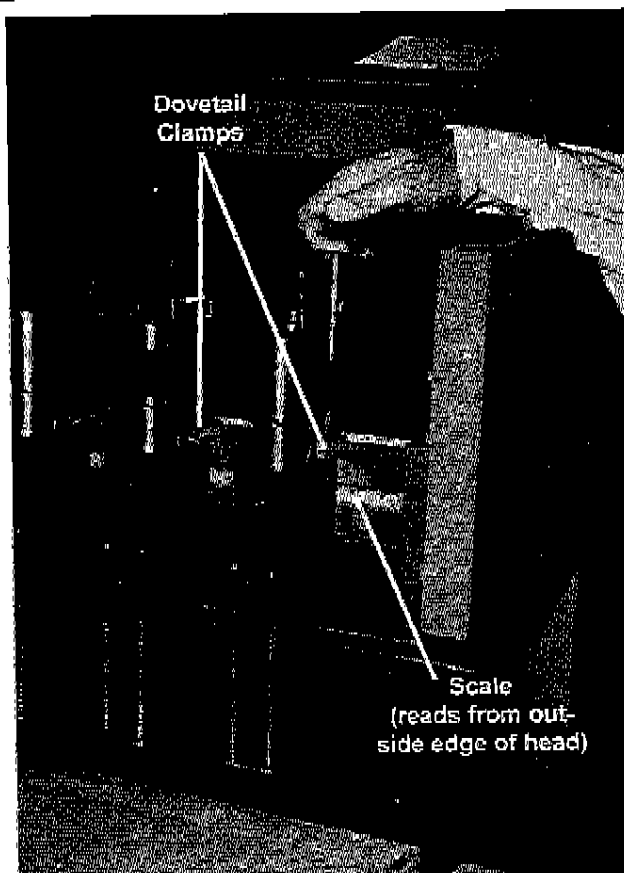

(fig. 5)

fied. The MS-5 handles two to five drilling heads mounted on a dovetail. Each head is independently adjustable allowing a minimum center-to-center distance of $1\frac{7}{8}$ " (47.6 cm) to a maximum center-to-center distance of 15" (381 mm). Any number of heads (up to five) or combination of drill hole sizes can be drilled at one time. However, when using $\frac{1}{2}$ " (13 mm) drills, it is recommended that no more than three heads be used at the same time.

Always position heads so that the lift of paper being drilled is centered on the table. Drill heads are mounted on a dovetail and positioned by a scale mounted on the front of the dovetail (fig. 5).

To move heads: raise the front cover and release the drive belt tension by lifting the belt lever. Loosen the socket head screws holding the head to the dovetail and position the heads according to the scale (fig. 5). The dovetail scale is calibrated from the center of the table and is setup to give readings to the center of the holes. The scale is read from the outside edge of the drill heads. (Heads mounted to the right of center read the scale from the right side, heads to the left of center are read to the left of the head.) Once the heads are in the desired position, tighten the socket head screws in the dovetail.

Drive Belt Adjustment

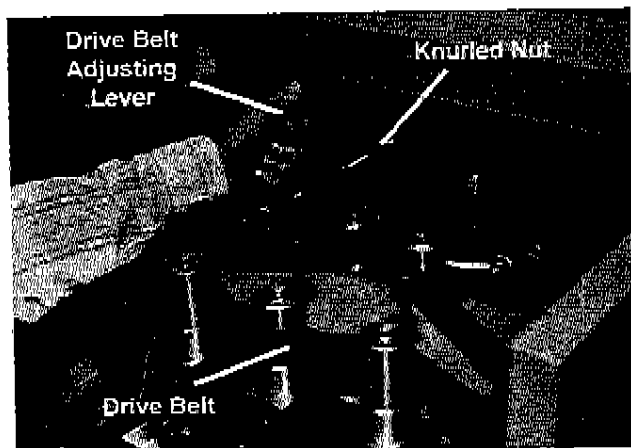

(fig. 6)

Whenever changing head configurations or repositioning heads, reset the drill head belt tension. This is done by backing off the knurled adjusting nut (fig. 6) with the belt lever in the up position. Lower the lever and turn the knurled nut out until it is tight. Raise the lever and turn the knurled nut out an additional $1\frac{1}{2}$ to 2 turns. Lower the lever and close the front cover.

Drill Installation



CAUTION: Always handle drills with care to avoid severe lacerations. Even dull drills are sharp enough to cause lacerations.

Insert the tapered head of the hollow drills into the spindles. Press the drills firmly into place so they do not fall out when the motor is first started. To prevent drill chips from flying out be sure that the drift hole cov-

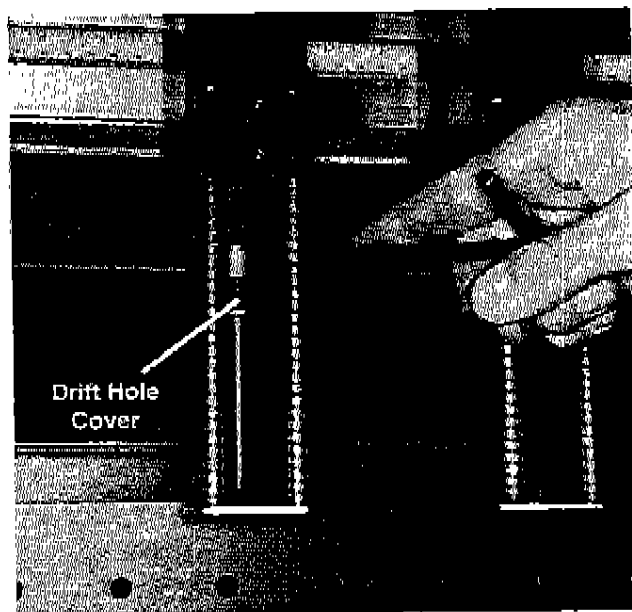

(fig. 7)

ers (black bands) are in place before operation (fig. 7).

Make sure the cutting stick blocks are in position before trying to drill paper.

Drill Removal

After use, drills may become seated making it difficult to remove them. Use the T-handled drill drift tool to free stuck drills. Uncover the drill drift hole by sliding the cover down. Insert the drill drift with the flat edge down and lift up to force the drill out of the head (fig. 7).

Stroke Adjustment (Table Height Adjustment)

Whenever installing new or resharpened drills, the table stroke and drill height must be adjusted. Turn in (clockwise) the table height adjustment to lower the table (fig. 3). Next, lift the front cover and back off the drill head adjustment on each head. Place a single sheet of paper under the drills and raise the table with the foot treadle. Gradually raise the table height by turning the table height knob out (counter clockwise) and pressing the foot treadle to check the table height. Continue to do this until the first drill cuts through the paper. Once the table height has been set, adjust the drill heads individually until all the drills now cut through the paper. When cutting full lifts, any further stroke adjustment can now be made with the table height adjustment knob.

Note: The MS-5 uses 2" and 2 $\frac{1}{2}$ " long drills. Be sure to adjust the table stroke and/or drill height accordingly when changing from one drill length to another.

Adjusting the Stroke Speed

The hydraulic unit is equipped with an adjustable valve for regulating the table stroke speed (up and down travel). Maximum speed is 18 strokes per minute which is the speed used on the average run of work. Soft stocks such as mimeographs, NCR, etc., are apt to wrinkle at high speeds, and the speed should be regulated to a point where the best results are obtained. This is found mostly by "trial and error."

This adjustment is made by turning the adjustable valve (located on the left side of the control panel) counterclockwise to reduce speed and clockwise to increase speed.

Never turn the speed control knob more than 2 $\frac{1}{2}$ turns counterclockwise (slow speed) as the drill will not bottom and engage the return cycle. Less than one turn counterclockwise should suffice for all drilling operations. Slow speeds may also cause the drills to "burn" through the paper. If burning occurs, either increase

the vertical speed, sharpen the drills or check for proper belt tension.

Slower vertical speeds are recommended when drilling with the maximum number of heads.

Setting Up the Backgage

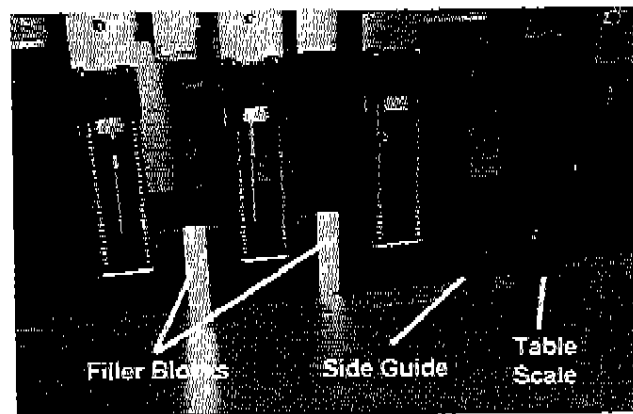

(fig. 8)

Scales are provided in the table for setting up the backgage. The scales read in inches/mm and will give you the dimension from the back of the sheet to the centerline of the holes. Two magnetic filler blocks are provided if it is necessary to drill within 1" of the edge of the sheet, fig. 8. The blocks are $\frac{1}{2}$ " (13 mm) thick and when used, $\frac{1}{2}$ " (13 mm) must be **subtracted** from the scale reading to give the set up dimension. Example: To drill $\frac{3}{4}$ " (19 mm) from the edge of the sheet, install the filler blocks and set the backgage to $1\frac{1}{4}$ " (32 mm) on the scale.

Using the Side Guide(s)

The adjustment for the location of the holes to the top or bottom edge of the sheet is provided by a sturdy side guide. The backgage has a series of threaded holes to which the side guide is attached with two threaded knobs. In addition, the side guide is slotted to fine adjust the position of the paper. When setting up drill head positions and side guides, always try to keep the paper centered on the table as much as possible.

Two side guides are provided as standard equipment so stock may be drilled to the left or right or for setting up multiple drilling sequences for more than five holes.

Drill Blocks

Place the drill blocks in the slot in the table. They are held tightly in place by pinching the drill block spring and placing it in the slot in the table at the end of the drill blocks (fig 9).

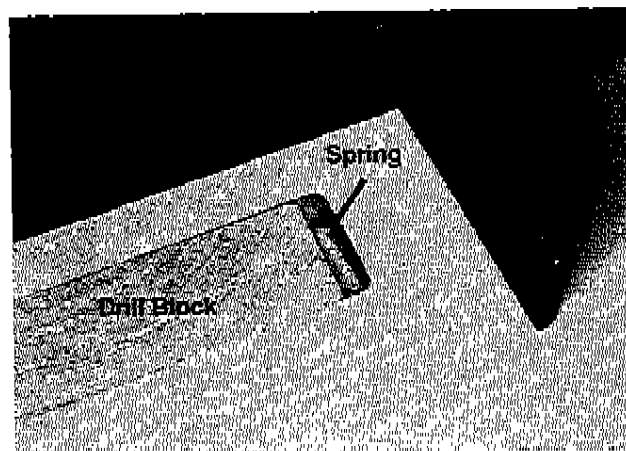

(fig. 9)

The drill blocks are removed by simply lifting them from their groove in the table. They should set flush with the table and may be shimmed if necessary. For best use and longest life, turn them end for end, top and bottom.

Emptying the Drill Chips

A large capacity chip bag attached to the rear of the machine, can be easily taken off and emptied by slipping it off the two hooks provided.

OPERATION

For EMERGENCY STOP release foot from treadle and turn main disconnect switch to "off" position.



CAUTION: NEVER REST YOUR FOOT ON THE TREADLE WITHOUT INTENDING TO BRING UP THE TABLE.



CAUTION: NEVER PUT HANDS OR FINGERS NEAR DRILL HEADS WHEN OPERATION THE MACHINE. SEVERE LACERATIONS COULD RESULT.

Pressing the foot treadle activates the hydraulic unit bringing the table and stock up to the drills and returning back again automatically. The pedal must be released and depressed again before the next drill cycle assuring full control and allowing no repeat stroke. Releasing the pedal at any time stops the table movement and returns it to its normal down position, thus preventing costly errors.

The vertical movement of the table is actuated by the hydraulic unit. Depressing the foot treadle sets the hydraulic unit into action. Keeping your foot on the

treadle allows the drills to drill through the entire lift of stock and reach the bottom of their stroke. At this point, the solenoid is de-energized and the valve released,

relieving the pressure off of the cylinder and allowing the table to return to the down position.

DRILLING TIPS

Important! To prevent the drill from overheating, always avoid drilling too slowly. The table should be brought up as rapidly as possible allowing the drills to easily cut through the paper. Also, adjust the vertical table guide to return the table to the down position as rapidly as possible to avoid spinning the drills in the stock.

Slotted Holes - Instead of punching slotted holes for five and seven hole universal binding work, save time and cost by drilling a 1/2 inch diameter hole in place of the slot. The slot is only intended to allow the post or ring to be used in either location, and the large hole permits this.

Plastic Bindings - Drilling holes for plastic bindings, instead of punching them, is practical and saves a great deal of time, particularly on long run jobs.

Keep Drills Sharp - A dull drill is the major cause of drill breakage and production tie-ups. Usually after three hours of drilling, depending on the type of paper being processed, the drill should be sharpened. A dull drill results in poor quality work.

Keep Drills Clean - A dirty and rusty drill will not permit the free upward passage of the drill chips. Pressure built up by a clogged drill will split or break the drill. To keep it free from dirt or rust, clean the drill of all chips after each use and apply a light oil to the inside and outside. Drills should be cleaned out immediately after each use. This is particularly true if a coated or varnished stock has been drilled. On these jobs the coating on the chips frequently fuse the chips into one solid mass when the drill cools, causing breakage the next time the drill is used.

Lubricate Drills - Lubrication assists in the passage of the chips and helps avoid overheating of the drills. Use readily available stick lubricants for this purpose. Hold the end of the stick against the side of the rotating drill. Be sure to touch the cutting edge with the lubricant also. Wipe off excess oil before drilling. **CARE MUST ALWAYS BE TAKEN WHEN HANDLING DRILLS.**

Keep Spindle Clean - Clean out the drill spindle frequently. This will prevent any buildup in the spindle of the drill.

Set the Drills Correctly - Do not cut too deeply into the cutting block. The drill should just touch the block and cleanly cut through the bottom sheet. During drilling, do not set the drill deeper into the block but change the position of the block frequently. Drilling deeper into the block dulls the drills quickly. Use a piece of chipboard underneath your stock. This will make handling the stock easier and will ensure that the last sheet is cut cleanly through.

Check for Drill Wobble - If spindles are badly worn or bent through misadjustment, have them replaced immediately. A wobbly or loosely held drill will break.

Check Your Drill Sharpener - The cutting edge of the sharpening bit should be inspected frequently to make certain that it is sharp and free of nicks. Never let a drill drop onto the sharpening bit. It will chip the sharpening edge. Use gentle pressure when sharpening - let the sharpening bit do the work. Check the sharpness of the drill after sharpening. The cutting edge should be razor sharp.

Just a little time and effort taken with each use of your paper drilling machine should result in trouble free operation over many years.

ACCESSORIES FOR CHALLENGE PAPER DRILLING MACHINES

Genuine Challenge Hollow Drills In 13 Standard Sizes For Every Drilling Need

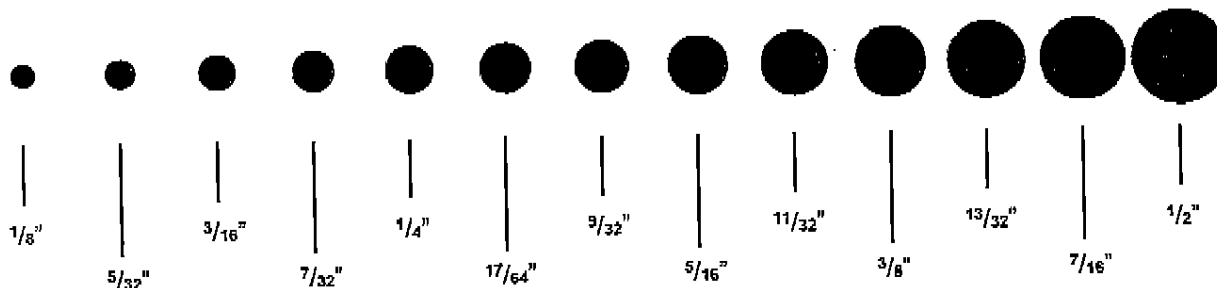

All drills carried in stock by local Challenge dealers ($17/32"$ & $9/16"$ available by special order).

HOLLOW DRILLS

Diameter x Drill Capacity	Cat. No.
$1/8" \times 5/8"$ (3.2 x 16 mm)	CD-2-3
$5/32" \times 1 1/8"$ (4 x 29 mm)	CD-52
$3/16" \times 1 5/8"$ (4.8 x 41 mm)	CD-3
$7/32" \times 2"$ (5.6 x 51 mm)	CD-72
$1/4" \times 2"$ (6.3 x 51 mm)	CD-4
$1/4" \times 2 1/2"$ (6.3 x 63.5 mm)	CD-4-2 $1/2$
$17/64" \times 2"$ (6.7 x 51 mm)	CD-174
$9/32" \times 2"$ (7.1 x 51 mm)	CD-92
$5/16" \times 2"$ (7.9 x 51 mm)	CD-5
$5/16" \times 2 1/2"$ (7.9 x 63.5 mm)	CD-5-2 $1/2$
$11/32" \times 2"$ (8.7 x 51 mm)	CD-112
$3/8" \times 2"$ (9.5 x 51 mm)	CD-6
$3/8" \times 2 1/2"$ (9.5 x 63.5 mm)	CD-6-2 $1/2$
$13/32" \times 2"$ (10.3 x 51 mm)	CD-132
$7/16" \times 2"$ (11.1 x 51 mm)	CD-7
$1/2" \times 2"$ (12.7 x 51 mm)	CD-8
$1/2" \times 2 1/2"$ (12.7 x 63.5 mm)	CD-8-2 $1/2$
Special order drills	
$17/32" \times 2"$ (13.5 x 51 mm)	CD-172
$9/16" \times 2"$ (14.3 x 51 mm)	CD-9

TEFLON COATED HOLLOW DRILLS

Diameter x Drill Capacity	Cat. No.
$1/8" \times 5/8"$ (3.2 x 16 mm)	TCD-2-3
$5/32" \times 1 1/8"$ (4 x 29 mm)	TCD-52
$3/16" \times 1 5/8"$ (4.8 x 41 mm)	TCD-3
$7/32" \times 2"$ (5.6 x 51 mm)	TCD-72
$1/4" \times 2"$ (6.3 x 51 mm)	TCD-4
$1/4" \times 2 1/2"$ (6.3 x 63.5 mm)	TCD-4-2 $1/2$
$17/64" \times 2"$ (6.7 x 51 mm)	TCD-174
$9/32" \times 2"$ (7.1 x 51 mm)	TCD-92
$5/16" \times 2"$ (7.9 x 51 mm)	TCD-5
$5/16" \times 2 1/2"$ (7.9 x 63.5 mm)	TCD-5-2 $1/2$
$11/32" \times 2"$ (8.7 x 51 mm)	TCD-112
$3/8" \times 2"$ (9.5 x 51 mm)	TCD-6
$3/8" \times 2 1/2"$ (9.5 x 63.5 mm)	TCD-6-2 $1/2$
$13/32" \times 2"$ (10.3 x 51 mm)	TCD-132
$7/16" \times 2"$ (11.1 x 51 mm)	TCD-7
$1/2" \times 2"$ (12.7 x 51 mm)	TCD-8
$1/2" \times 2 1/2"$ (12.7 x 63.5 mm)	TCD-8-2 $1/2$

Challenge Drill-Ease Lubricant Stick

Cat. No. 4688

This lubricating stick provides a dry stainless lubricant which has many uses throughout the printing plant. It is specially recommended for use on hollow drills for easier drilling, particularly when drilling clay coated stock. It eliminates binding and excessive heating of the drill. Will not discolor the stock.

CARE MUST ALWAYS BE TAKEN WHEN USING STICK AND HANDLING DRILLS.

Challenge Drilling Blocks

Cat. No. A-6626-24

These Challenge $1 1/4" \times 6"$ End-Wood Drilling Blocks are for round hole drilling operations. Sold in packages of 24.

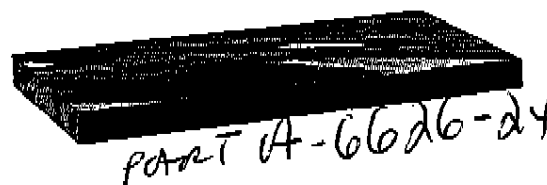

ACCESSORIES FOR CHALLENGE PAPER DRILLING MACHINES

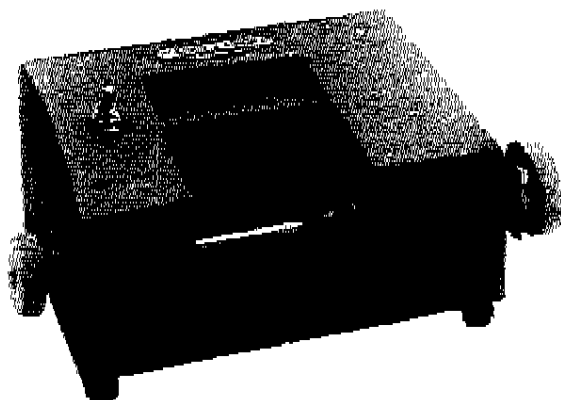

Challenge Power Sharpener

(115 Volt / 60 HZ only)

Cat. No. A-6450

A power drill sharpener. Plugs into any standard 115 volt, 60 cycle, AC outlet. Handles Challenge and other taper shank drills. Adaptors also available for handling practically all other makes.

Item	Cat. No.
Replacement Cutting Bit	6469
Resharpener Service - Your Old Bit	6469-R

HOLLOW DRILL SHARPENER *For fast, easy drill sharpening*



CAUTION: Drills are sharp even after use. Be careful to keep edge away from your body. To prevent personal injury and/or damage to the drill, ALWAYS keep drills in protected area.

Here's a unit that really makes drill sharpening easy. All you do is place the hollow drill in the tapered end of the drill holder, insert the unit on the cylinder, then turn two or three times...and you have a perfectly sharpened drill.

This Challenge Hollow Drill Sharpener can pay for itself many times over through longer drill life, easier, faster drilling, and less sharpening time. All sizes of drills from 1/8 to 1/2 inch in diameter can be sharpened.

The drill sharpener automatically puts just the right amount of bevel on the hollow drill for the best drilling results. It's self centering, too, so that the center of the sharpening bit exactly meets the center of the hollow drill. The drill sharpener also has a replaceable sharpening bit.

Item	Cat. No.
Challenge Hollow Drill Sharpener	A-4950
Extra Cutting Bit	4952

Instructions:

NOTE: Always handle carefully

1. Be sure to wipe off all grease before using the sharpener.
2. Remove any paper chips from the hollow drill.
3. Place the hollow drill in the drill holder section. Insert the sharpening section, being very careful to bring the drill and cutting tool together without bumping.

NOTE: The cutting tool is made of a glass hard material and may be chipped by careless handling.

4. Turn the cutting unit clockwise, maintaining an even pressure until the hollow drill is sharpened (usually two or three turns). The cutting tool seldom requires regrinding, but when it does, the bit should be sent to the factory as regrinding must be done on a diamond wheel.

ACCESSORIES FOR CHALLENGE PAPER DRILLING MACHINES

Optional Narrow Drill Head Assembly, p/n: 45200

For drilling holes with a center to center distance as low as 1-3/8"/3.5 cm

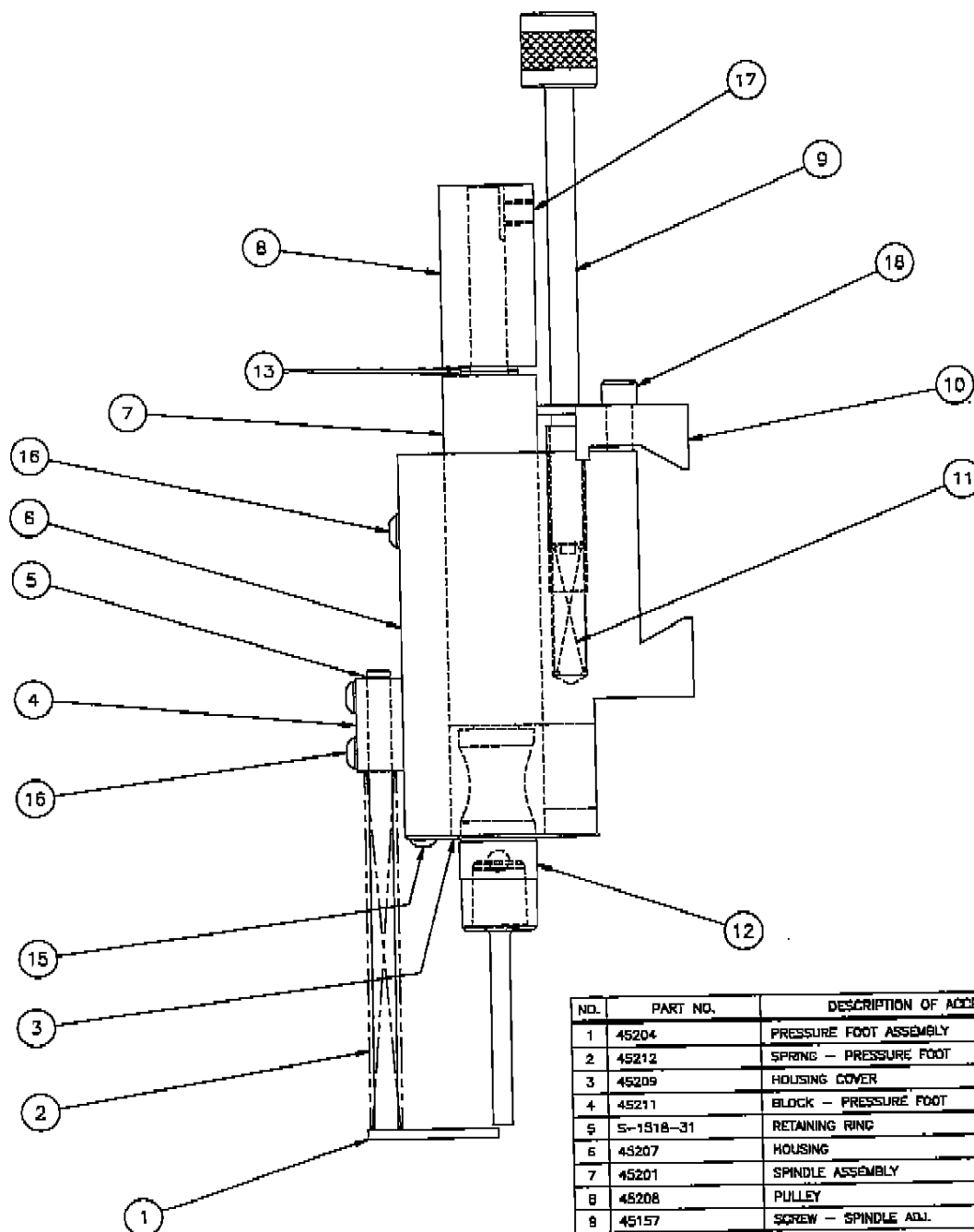

NO.	PART NO.	DESCRIPTION OF ACCESSORIES	QTY
1	45204	PRESSURE FOOT ASSEMBLY	1
2	45212	SPRING - PRESSURE FOOT	2
3	45209	HOUSING COVER	1
4	45211	BLOCK - PRESSURE FOOT	1
5	S-1518-31	RETAINING RING	2
6	45207	HOUSING	1
7	45201	SPINDLE ASSEMBLY	1
8	45208	PULLEY	1
9	45157	SCREW - SPINDLE ADJ.	1
10	45210	CLAMP	1
11	35048-4	SPRING	1
12	K-85	COVER - DRILL DRIFT HOLE	1
13	20075-10	STEEL SHIM	2
14			
15	H-6910-102403	SCREW - #10-24 x 3/8 BUTTON HEAD CAP	2
16	H-6910-407	SCREW - 1/4-20 x 7/8 BUTTON HEAD CAP	3
17	H-6938-503	SCREW - 5/16 x 3/16 SOCKET SET	1
18	H-6918-510	SCREW - 5/16-18 x 1-1/4 SOCKET HEAD	2

⚠ NOTICE ⚠

The instructions on the following pages are for the use of trained service personnel only!

Attempting to perform repair and replacement procedures without proper training may cause machine damage or operator injury!

PARTS CUSTOMERS: The Challenge Machinery Company provides parts with the express understanding that they are to replace parts found missing or no longer serviceable on equipment designed and/or manufactured by Challenge. The Challenge Machinery Company assumes no liability for any modification or alteration to any Challenge products, and any such modification or alteration to any Challenge products is not authorized by The Challenge Machinery Company. Any modification or alteration of any Challenge product will void any remaining warranty.

TROUBLESHOOTING



WARNING: DISCONNECT THE POWER AND LOCK IT OUT whenever working on the machine unless the instructions specifically require the machine to be powered (see Power Lockout Procedure, page 4). Several of the following tests may require the machine to be operational for checking and adjusting. Be very careful that tools and other people are clear of moving parts, and that the drill is not accidentally operated while adjustments are being made.



CAUTION: Whenever repairing hydraulic components, loosen connections slowly to bleed off any trapped pressure.

Problem	Area to Check	Solution
1. No power	Power to machine	Connect Power
	Main Disconnect Switch	Turn to ON position
	Interlocking Guards	Replace guards
	Fuse blown	Replace fuse - see fig. 2 page 7
2. Lack of power	Relief valve in pump may be bad or have dirt in it.	Clean or replace relief valve or pump.
	Check oil level - may be low.	Add oil.
	Check voltage at machine - may be low.	Remove other machinery on line or provide a dedicated line.
3. Spindle motor stalls	Dull drills.	Sharpen drills.
	Check for low voltage.	(See above).
	Check drive pulley and belt for tightness.	(See SETUP INSTRUCTIONS in main section for adjustment).
	Check for paper plugging drills	Clean out hollow drills - We recommend cleaning and soaking drills in oil overnight.
4. Table stroke won't adjust	Stroke Adjustment Chain off sprockets.	Remove back panel and replace chain (fig. 10).

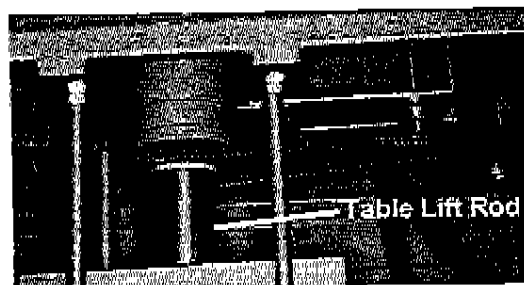

(fig. 10)

ROUTINE MAINTENANCE

General

Production losses can be reduced if good maintenance practices are followed. The following suggestions may be helpful:

1. Recognize the fact that the user of hydraulic equipment has more control over maintenance than the manufacturer.
2. Operators should be familiar with use, care, and limitations of the equipment. **ALL OPERATORS SHOULD READ THIS MANUAL COMPLETELY.**
3. Use properly trained maintenance personnel.
4. Establish a program of systematic preventative care for your equipment or put this machine on an existing preventative maintenance program.
5. Analyze and isolate trouble before having any part of the equipment dismantled.
6. Be aware of how your machine should sound and perform. If the machine is not operating properly or if it doesn't "sound right", stop running your job immediately and try to identify the problem.
7. Call the dealer for any problems that cannot be handled by your own personnel.

Vertical Table Guide

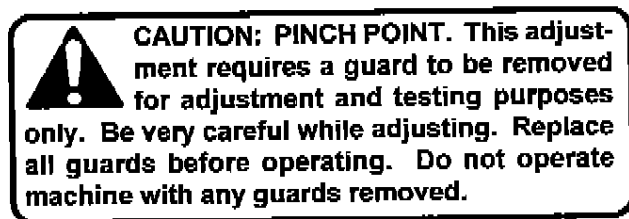

The vertical table guide is located on the right side of the machine beneath the table and may need periodic adjustment to keep the table steady yet allow it and stock to fall away from the drills as rapidly as possible. The table down stroke is controlled by a return spring.

Remove the guide block cover guard. Tighten the two guide block lock nuts (fig. 11) and power the table up by pressing the foot treadle. Gradually back the lock-nuts off evenly until the table releases freely. Retest the upstroke and table return, and check the table for side play. Replace the guard.

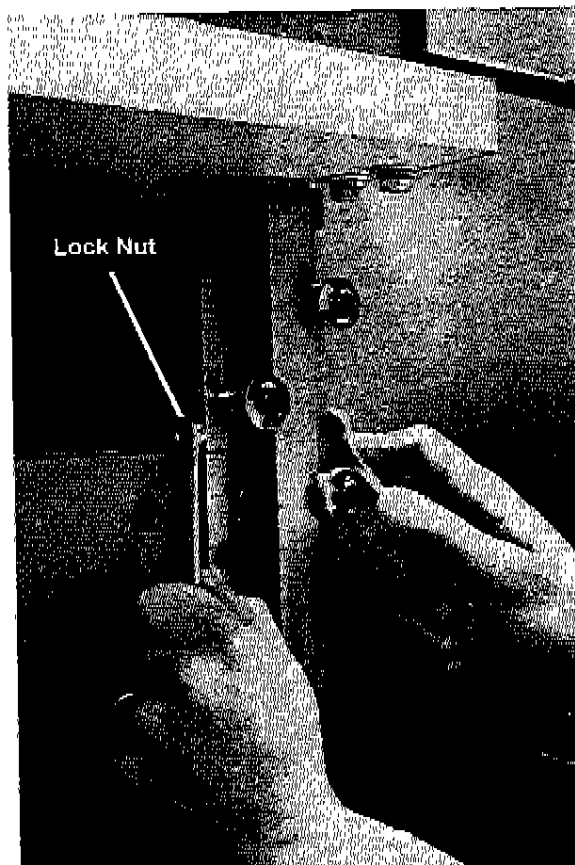

▲ CAUTION: PINCH POINT.
Replace guard after adjusting.

(fig. 11)

SERVICE CHECKLIST

Daily

1. Keep drills sharp!
2. Lubricate the hollow drill frequently with the lubricating stick provided.
3. For better hollow drill life, remove the drills when not in use and soak in light oil. Wipe off excess oil before drilling.
4. Wipe off excess grease from the drill heads and idlers.

Weekly (or every 40 hours of operation)

1. Check belt wear/tension.
2. Oil the table lift rod between the table and stand with light oil (fig. 10).

Monthly

1. Oil the table height adjusting knob shaft with a light machine oil. Wipe off excess oil.
2. Check the hydraulic oil supply for the proper level. This check is made by removing the rear panel and removing the dip stick/plug (pg. 8, fig. 3). The oil should be visible on the dip stick but no higher than 1/2" up from the bottom when cool. This allows for expansion of the oil when hot. Use only one of the recommended oils or an ISO VG 100 Hydraulic Fluid equivalent. Oils other than the recommended type will cause seals, cups and O-rings to deteriorate. See Chart & CAUTION.

Super Hydraulic 100
Nuto H-100
Harmony 100 AW
HO 2A Hydraulic Oil
DTE No. 18
Pennzoil AW 100
Magnus A Oil 215
Tellus 100
Energol HLP 100
Industron 100
Sunvis 851 WR
Rando HD 100
Unax AW 100

Conoco
Exxon
Gulf
Lubriplate
Mobil
Pennzoil
Phillips
Shell
Sohio
Std. Oil Indiana/Boron
Sunoco
Texaco
Union Oil Co.

Yearly

1. Check all adjustments.
2. Tighten all screws.
3. Change hydraulic oil in reservoir. Oil may have to be changed more often if contamination of any kind gets in the oil.

Hydraulic

Through normal use, hydraulic systems gum up and seals wear. Signs of wear are hydraulic leaks and erratic operation of the vertical speed. Check with your Authorized Challenge Dealer for a current repair and/or replacement policy.

Drill Heads

Through normal use, bearings will wear and need replacing. Signs of wear are excessive noise, heat, or loose spindles.



CAUTION: NEVER USE Automatic Transmission oil or brake fluid as a substitute! Oils other than the recommended type will cause seals, cups and O-rings to deteriorate. Unsafe operating conditions will result.

Recommended Oils

Oil Name	Distributor
Rykon No. 100	AMOCO
Duro AW Oil 465	Arco
AW Machine Oil 100	Chevron
Pacemaker XD No. 100	Citgo

NOTES

MAIN ASSEMBLY - FRONT VIEW 45000 SHEET 1 REV L

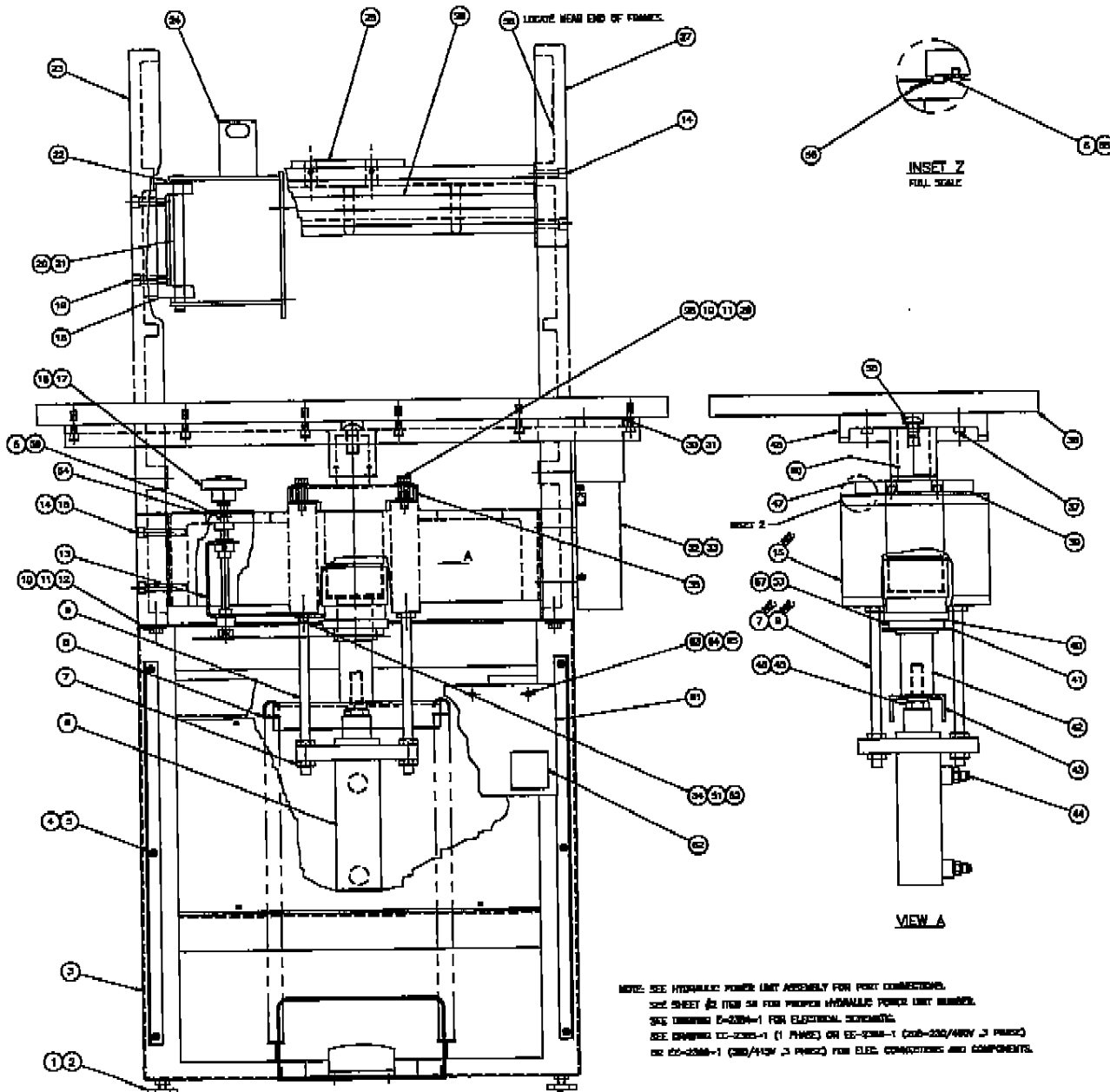

MAIN ASSEMBLY - FRONT VIEW 4500 SHEET 1 REV L

NO.	PART NO.	DESCRIPTION OF ACCESSORIES	QTY
1	16543	LEVELER	4
2	H-6424-6	3/8-16 HEX JAM NUT	4
3	45051	BASE ASSEMBLY	1
4	45040	BRACKET - LOWER BASE COVER	2
5	H-6910-102404	#10-24 X 1/2 BUTTON HD SOC. CAP SCREW	9
6	H-377	HYDRAULIC CYLINDER	1
7	H-6424-8	1/2-13 HEX JAM NUT	12
8	6843-1	SPRING - TABLE RETURN	2
9	45007	ROD - CYLINDER MOUNTING	4
10	H-7327-12	3/8 MEDIUM LOCKWASHER	8
11	H-7321-6	3/8 FLAT WASHER	8
12	H-6913-608	3/8-16 X 1 HEX HD CAP SCREW	4
13	45136-1	TABLE ADJUSTMENT ASSEMBLY	1
14	H-6918-616	3/8-16 X 2" SOC. HD. CAP SCREW	14
15	45073	BRACE - CROSS	1
16	S-1753-2	KNIFE - TABLE ADJUSTMENT	1
17	H-6424-6	3/8-16 HEX JAM NUT	1
18	45070	BRACKET - MOTOR	1
19	H-6918-612	3/8-16 X 1-1/2 SOC HD CAP SCREW	2
20	48001	PIN - MOTOR	1
21	S-1193-30	1/2 "E" RING	2
22	11288	WASHER - NYLON	1
23	45077	SIDE FRAME - L.H.	1
24	45002	BRACKET ASSEMBLY - MOTOR	1
25	45078	DIAMETAL	1
26	45065	SCALE - DRILL HEAD	1
27	45075	SIDE FRAME - R.H.	1
28	H-6913-612	3/8-16 X 1-1/2 HEX HD CAP SCREW	4
28	11288-1	WASHER - NYLON	4
30	45117	COVER - TABLE GUIDE - TOP	1
31	S-1088-5	#10 X 5/8 TYPE A8 SCREW	2
32	45017	COVER - VERTICAL TABLE GUIDE	1
33	H-6910-102402	#10-24 X 1/4 BUTTON HD SOC. CAP SCREW	4

NO.	PART NO.	DESCRIPTION OF ACCESSORIES	QTY
34	H-7321-4	1/4 FLAT WASHER	2
35	45092	COVER - TABLE ROD GUIDE	1
36	45011-2	TABLE	1
37	H-6918-510	5/16-18 X 1-1/4 SOC HD CAP SCREW	11
38			
38	45084	ISOLATOR	2
40	45131	NUT - ADJUSTING	1
41	45135-1	CHAIN	1
42	45115-1	ROD - TABLE	1
43	45037	BRACKET - RETURN SPRING	1
44	H-236-3	ADAPTER - 9/16-18 S.A.E. "O" RING TO TUBE	2
45	H-6913-1012	5/8-11 X 1-1/2 HEX HD. CAP SCREW	1
46	H-7327-20	5/8 MEDIUM LOCKWASHER	1
47	45137	GUIDE ASSEMBLY - TABLE ROD	1
48	45115-2	BRACKET - TABLE MOUNTING	1
49			
50	H-6910-1010	5/8-11 X 1-1/4 BUTTON HD. CAP SCREW	1
51	45118	STOP - TABLE TRAVEL	1
52	H-6918-405	1/4-20 X 5/8 SOC. HD CAP SCREW	2
53	45138	SPROCKET - TABLE ADJ.	1
54	45142	DECAL - TABLE ADJ.	1
55	H-7330-#10	#10 EXT. TOOTH LOCKWASHER	1
56	EE-2425	WIRE ASSEMBLY - AUTO TRIP	REF
57	H-6910-63206	SCREW - #8-32 X 1" BUT HD CAP	2
58	S-1781-15	LABEL - CAUTION	2
58	45165	BLOCK - TABLE ADJ. ROD	1
60	H-6938-406	SCREW, 1/4-20 X 3/8 SOC SET SCR	2
61	47157-5	SHIELD - PLEDOGLASS	1
62	S-1781-35	LABEL - SHOCK HAZARD	1
63	E-1152-36	SPACER - 1/4-20 X 2"	2
64	H-6910-403	SCREW - 1/4-20 X 3/8 BUT HD. CAP	2
65	H-7324-6	WASHER - 1/4-20 INT. TOOTH	2

MAIN ASSEMBLY - SIDE VIEW
45000 SHEET 2 REV K (S/N 975272 & BELOW)

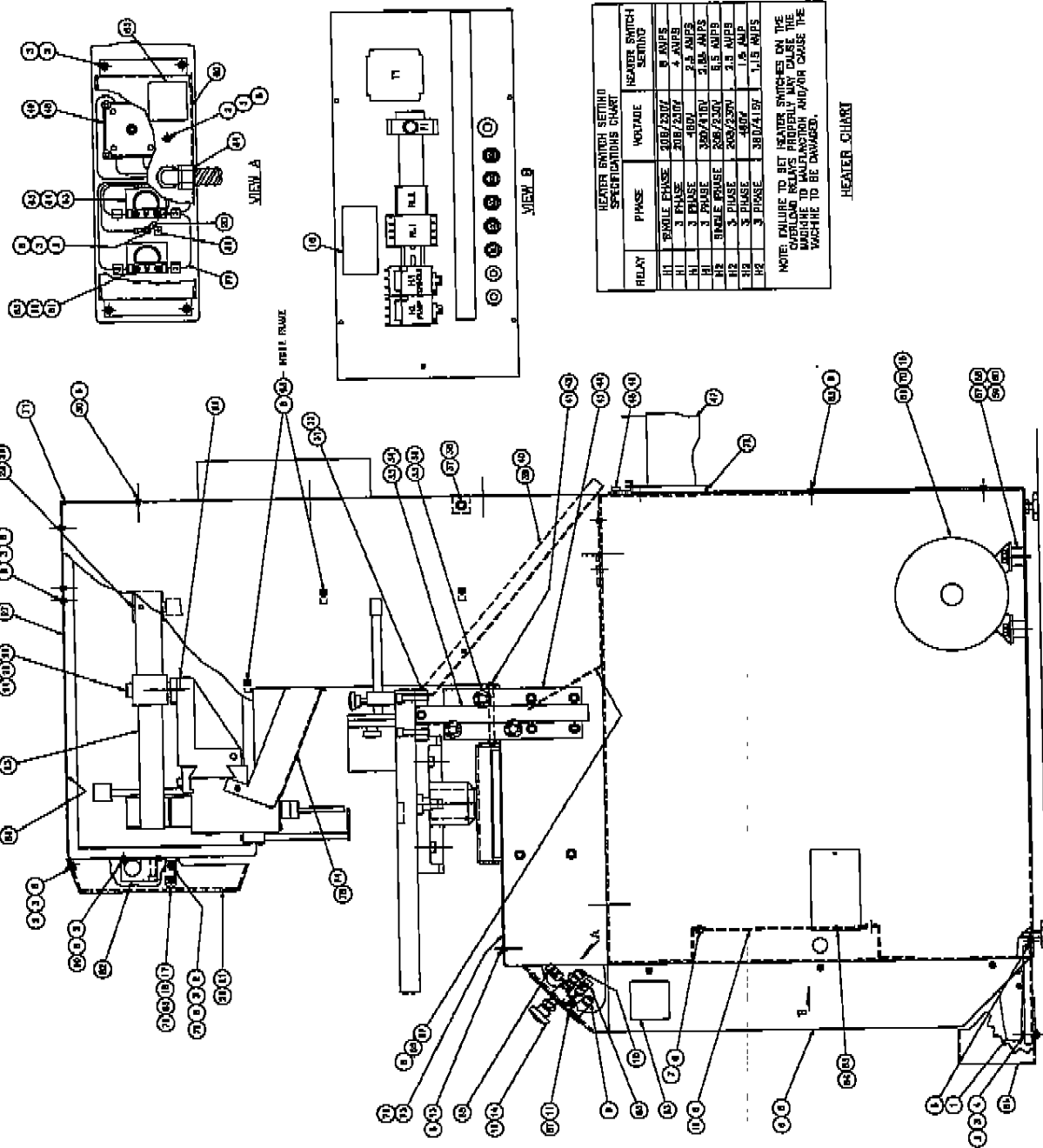

HEATER SWITCH SETTING SPECIFICATIONS CHART

RELAY	PHASE	VOLTAGE	HEATER SWITCH SETTING
H1	TRIPLE PHASE	208/230V	9 AMPS
H1	3 PHASE	208/230V	4 AMPS
H1	3 PHASE	480V	2.5 AMPS
H1	3 PHASE	330V/110V	5.5 AMPS
H2	TRIPLE PHASE	208/230V	6.5 AMPS
H2	3 PHASE	208/230V	3.3 AMPS
H2	3 PHASE	480V	1.8 AMP
H2	3 PHASE	330V/110V	1.8 AMPS

HEATER CHART

NOTE: FAILURE TO SET HEATER SWITCHES ON THE CARTRIDGE RELAYS PROPERLY MAY CAUSE THE MACHINE TO MALFUNCTION AND/AIR CAUSE THE MACHINE TO BE DAMAGED.

**MAIN ASSEMBLY - SIDE VIEW
45000 SHEET 2 REV K (S/N 975272 & BELOW)**

NO.	PART NO.	DESCRIPTION OF ACCESSORIES	QTY	REF.
1	E-878-4	FOOTSWITCH (REPAIR ONLY)	1	
2	H-7324-110	#10 INT. TOOTH LOCKWASHER	21	
3	H-862-110	#10-24 HEX NUT	10	
4	H-8818-102408	#10-24 X 3/4 SOG. HD CAP SCREW	2	
5	45048	COVER - LOWER BASE	1	
6	H-4810-102404	#10-24 X 1/2 BUTTON HD SOG. CAP SCREW	82	
7	H-7330-110	#10 EXT. TOOTH LOCKWASHER	4	
8	EE-2300-1	POWER PUL. ASSY - (3PHASE)	1	
9	EE-2300-1	POWER PUL. ASSY - (SINGLE PHASE)	1	
10	EE-2300-1	POWER PUL. ASSY - (300/418V) (3 PHASE)	1	
11	H-237-5	ELBOW FIT - 1/8 NPT X 9/16-18 TUBE	1	
12	H-241-5	ADAPTER - 1/8 NPT X 9/16-18 TUBE	1	
13	48110	PANEL - CONSOLE	1	
14	4771-1	VALVE	1	
15	45001	COVER	1	
16	H-7922-8	1/2 POLISHED WASHER	1	
17	S-1086	TYRAP	2	
18	S-1781-11	CAUTION LABEL - SHOCK	1	
19	H-8638-10	#8-32 HEX NUT	2	
20	H-7324-10	#8 INT. TOOTH LOCKWASHER	2	
21	EE-2783	WIRE ASSEMBLY - ORKARD	1	
22	48047-1	COVER - FRONT	1	
23	45109	LABEL	1	
24	45109	DRIVE BELT	1	
25	45129	PULLEY ASSEMBLY (MOUNTED)	2	
26	20076-7	SHIM	2	
27	45043	COVER ASSEMBLY - TOP	1	
28	45103	DRIVE PULLEY - 90 CYCLE	1	
29	45103-2	DRIVE PULLEY - 110 CYCLE	1	
30	H-8838-404	1/4-20 X 1/4 TUP PT. SOG. SET SCREW	3	
31	45119	PLATE - SERIAL NUMBER	1	
32	H-8824-004	#2 X 1/4 HD. HD DRIVE BORE	2	
33	45058	COVER - REAR	1	
34	H-578-1	100. POWER UNIT ASSY. (60/800 1 PH.)	1	
35	H-107-1	HPD POWER UNIT ASSY. (50/800 G. 3 PH)	4	
36	40031-2	VARIATION MOUNT	4	
37	H-7321-5	5/16 FLAT WASHER	4	
38	H-7327-10	5/16 MED LOCKWASHER	4	
39	H-8493-3	5/16-16 HEX NUT	4	
40	45119	COVER ASSEMBLY - REAR	1	
41	45018	BLOCK - GUIDE	1	
42	H-8818-812	3/8-18 X 1-1/2 SOG. HD CAP SCREW	3	
43	45018	GUIDE - VERTICAL	1	
44	H-315-800-1750	1/2 X 1-3/4 ROLL PIN	1	
45	S-1075-80	1/2" RETAINING RING	3	
46	A-10207-8	BEARING - PLANGED (BRONZE)	3	
47	H-4818-118	3/8-18 X 2" SOG. HD CAP SCREW	8	
48	45107	TYRAP	1	
49	45002	CHP GUIDE - LOWER	1	
50	H-200 X 3/4 SOG. SHOULDER SCREW	3		
51	45001	BLUD - TABLE GUIDE	2	
52	H-9248-4	1/4-28 FLEX LOCK NUT	1	
53	45012	VERTICAL TABLE GUIDE ASSEMBLY	1	
54	H-8918-808	3/8-18 X 1" SOG. HD CAP SCREW	4	
55	8670	HOOK - CHP BAG	2	
56	H-5918-804	8/16-18 X 1/2 SOG. HD CAP SCREW	2	
57	45061	CHP BAG ASSEMBLY	1	
58	E-2484	SWITCH - MAIN DISCONNECT	1	
59	E-2486	SWITCH FUSE - MAIN DISCONNECT	1	
60				
61				
62				
63				
64				
65				
66				
67				
68				
69				
70				
71				
72				
73				
74				
75				
76				
77				
78				
79				
80				
81				
82				
83				
84				
85				
86				
87				
88				
89				
90				
91				
92				
93				
94				
95				
96				
97				
98				
99				
100				

* TO REPLACE THIS SWITCH, ORDER KIT #. K-45181 (KIT INCLUDES NEW SWITCH)

MAIN ASSEMBLY - TOP VIEW
45000 SHEET 3 REV F

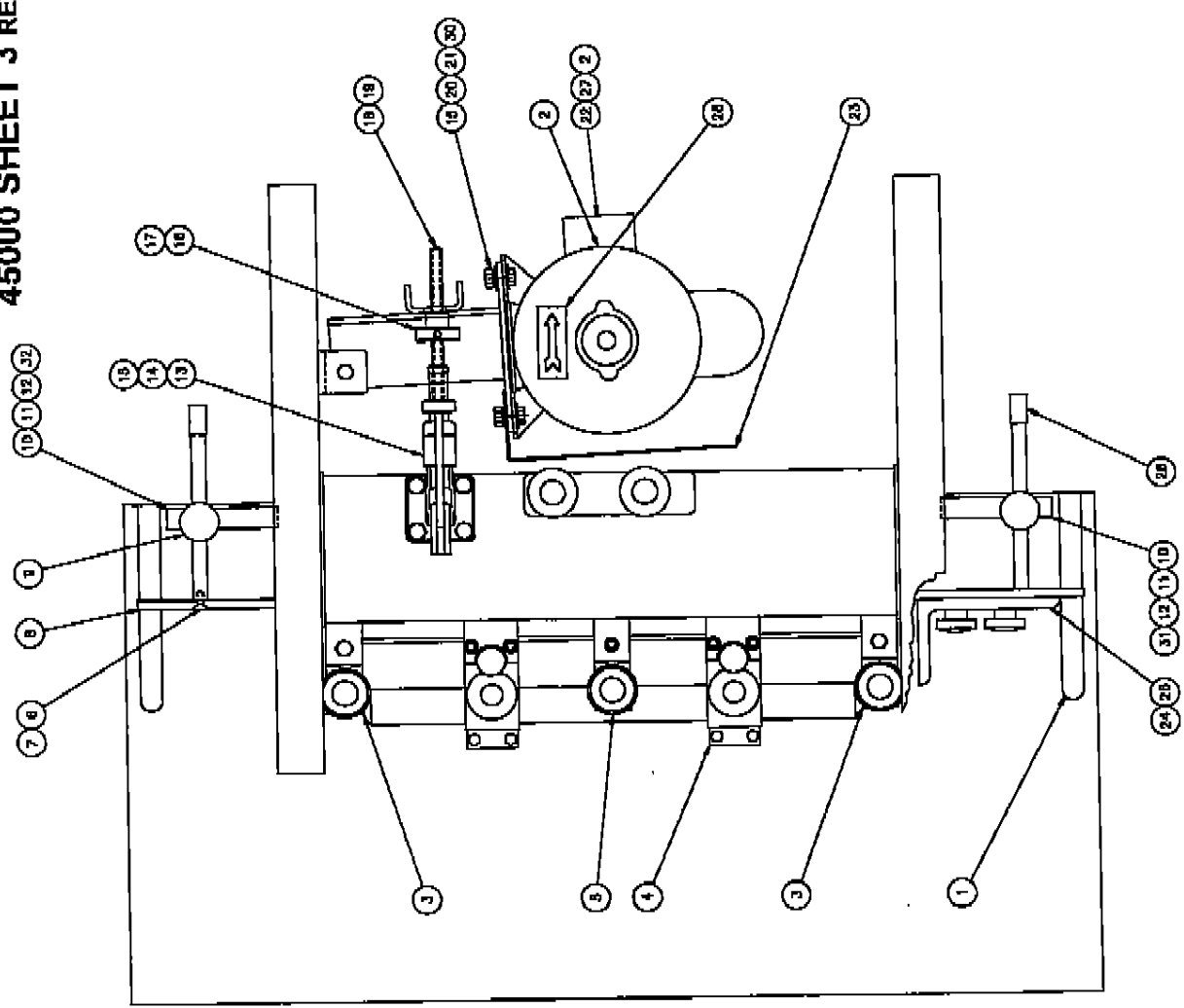

NO.	PART NO.	DESCRIPTION OF ACCESSORIES	QTY
1	4838-3	SCALE - B/O POSITION	2
2	5-1781-12	CAUTION LABEL	1
3	45035	ROLLER ASSEMBLY - STATIONARY	2
4	48152	DRILL HEAD ASSEMBLY	AS REQ'D
5	45181	ROLLER ASSEMBLY (2 HEAD MACHINES ONLY)	1
6	H-9809-405	1/4-20 X 5/8 FLAT HD SDC CAP SCREW	2
7	40018	ROD - 9/8 GUIDE	2
8	45020	BACKGUIDE	1
9	8278-3	KNOB	2
10	45018	BLOCK - BACKPAGE GUIDE (6D Hx.)	2
11	H-9813-814	3/8-16 X 1-3/4 HEX HD CAP SCREW	4
12	H-7321-8	3/8 FLAT WASHER	4
13	45008	CLAMP	1
14	H-9813-808	5/16-18 X 3/4 HEX HD CAP SCREW	4
15	H-7327-10	5/16 MED. LOCKWASHER	8
16	45080	KNOB - BELT TENSORER	1
17	H-9884-604	1/4-20 X 1/4 SDC SET SCREW (BRASS TIP)	1
18	45058	STUD - BELT TENSORER	1
19	H-8423-8	3/8-18 HEX NUT	1
20	H-7321-5	5/16 FLAT WASHER	4
21	H-8423-5	5/16-18 HEX NUT	4
22	E-1800-182	MOTOR (208-230/460 V. 3 PH. 60 C.)	1
	E-1800-182	MOTOR (208-230 V. 1 PH. 60 C.)	
	E-1800-188	MOTOR (208-230/580-415 V. 3 PH. 60 C.)	
	E-1800-190	MOTOR (208-230 V. 1 PH. 60 C.)	
23	48148	BRACKET - CHIP DEFLECTOR	1
24	45058	SIDEGUIDE	2
25	8278-4	KNOB	4
26	48143	WIRE NUT (YELLOW)	2
27	E-1237-1	WIRE NUT (YELLOW)	3
28	5-1108	ARROW DECAL	1
29	45108-1	TOOL KIT (NOT SHOWN)	1
30	H-9813-508	5/16-18 X 1" HEX HD CAP SCREW	4
31	45018-1	BLOCK - BACKPAGE GUIDE, R.H. (60 Hx.)	1
32	45018-2	BLOCK - BACKPAGE GUIDE, L.H. (60 Hx.)	1

MAIN ASSEMBLY - DRILL GUARD (50 HZ ONLY)
45000 SHEET 4 REV A (S/N: 975272 & BELOW)
(KIT FOR 60 HZ MACHINES: K-45180)

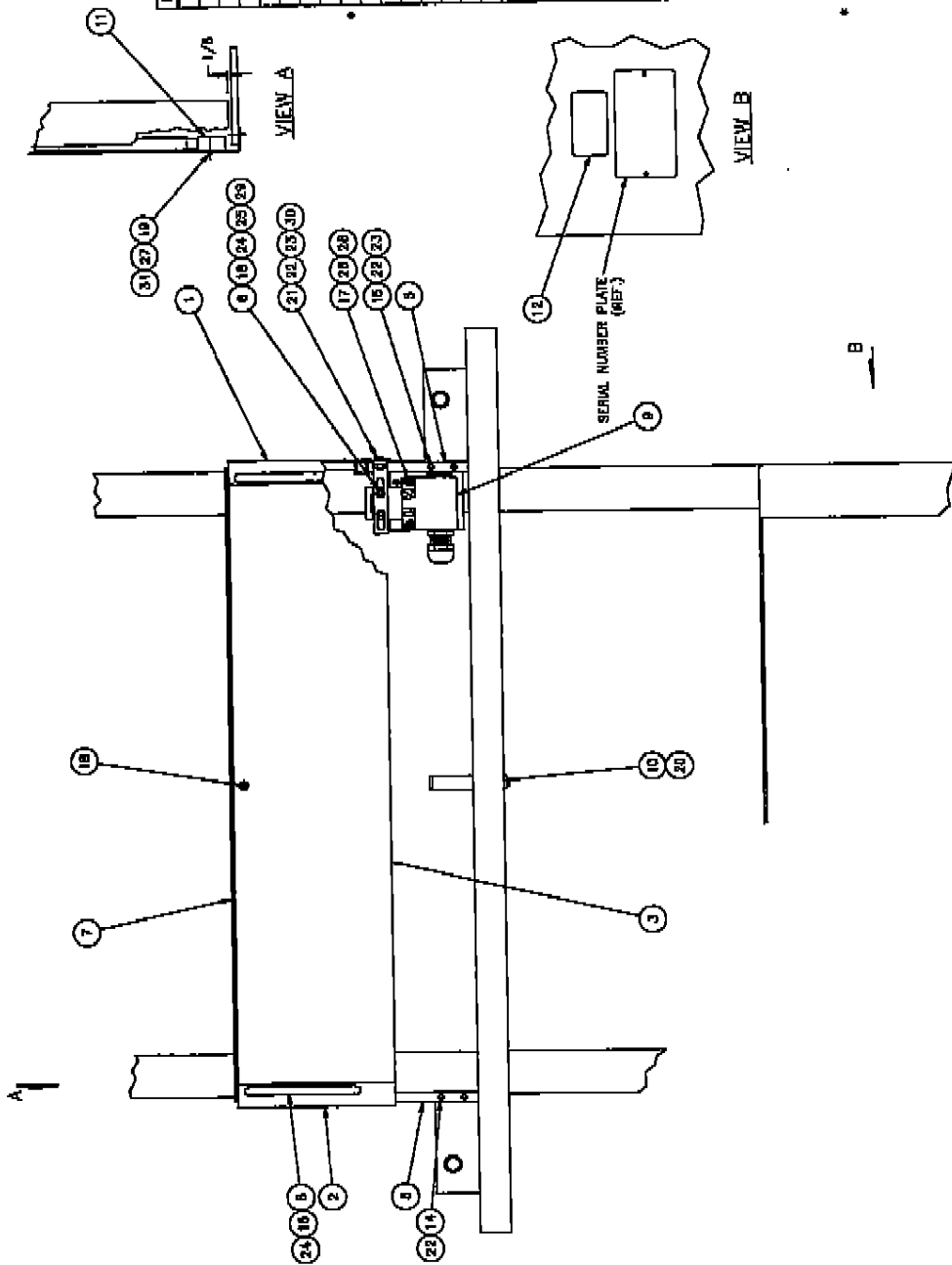

NO.	PART NO.	DESCRIPTION OF ACCESSORIES	QTY
1	45176	GUARD - R.H. SIDE	1
2	45170	GUARD - L.H. SIDE	1
3	45171	GUARD - CENTER, LEVAN	1
4		SUPPORT - BRIDGE GUARD	2
5	45174	BRACKET - GUARD INTERLOCK KEY	1
7	45177	SUPPORT - SHIELD	2
8	13940	HANDLE	1
9	EE-9790	SWITCH ASBL - TABLE	1
10	45178	WIPER - CHIP CLEANER	1
11	45179	SWITCH - MANDREL	2
12	8177-8	LABEL - CR MARK	1
13		SCREW - #10-24 X 1" 500 PZ CAP	2
14	14-8918-105408	SCREW - #10-24 X 1-1/4 500 PZ CAP	2
15	14-8918-02410	SCREW - #10-24 X 1-1/4 500 PZ CAP	2
16	14-8910-83100	SCREW - #8-32 X 3/8 500 PZ CAP	4
17	14-8923-83120	SCREW - #8-32 X 3/8 500 PZ CAP	2
18	14-8910-83800	SCREW - #10 X 3/8 TYPE AB	2
19	14-8923-84613	SCREW - #10 X 3/8 TYPE AB	2
20	8-1038-8	SCREW - #10-24 X 1/2 BUT. HD	2
21	14-8910-101404	WASHER - #10 BUT. TOOTH	2
22	14-7384-#10	WASHER - #10 INCH TOOTH	2
23	14-7384-#8	WASHER - #8 INCH TOOTH	2
24	14-7384-#6	WASHER - #6 INCH TOOTH	2
25	14-7384-#4	WASHER - #4 INCH TOOTH	2
26	14-7384-#2	WASHER - #2 INCH TOOTH	2
27	14-8420-#8	NUT - #8-32 HEX	2
28	14-8420-#6	NUT - #6-32 HEX	2
29	14-8420-#4	NUT - #4-40 HEX	2
30	14-8420-#2	NUT - #2-40 HEX	2
31	14-8420-#1	NUT - #1-40 HEX	2

* TO REPLACE THIS SWITCH, ORDER KIT #: K-45182
 (KIT INCLUDES NEW SWITCH)

BELT INSTALLATION

STANDARD DRILL HEADS

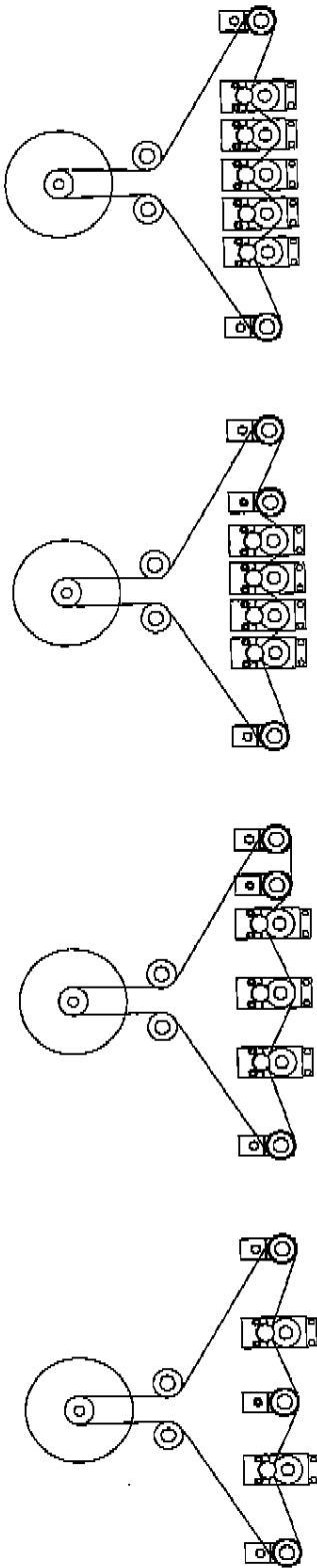

NARROW DRILL HEADS

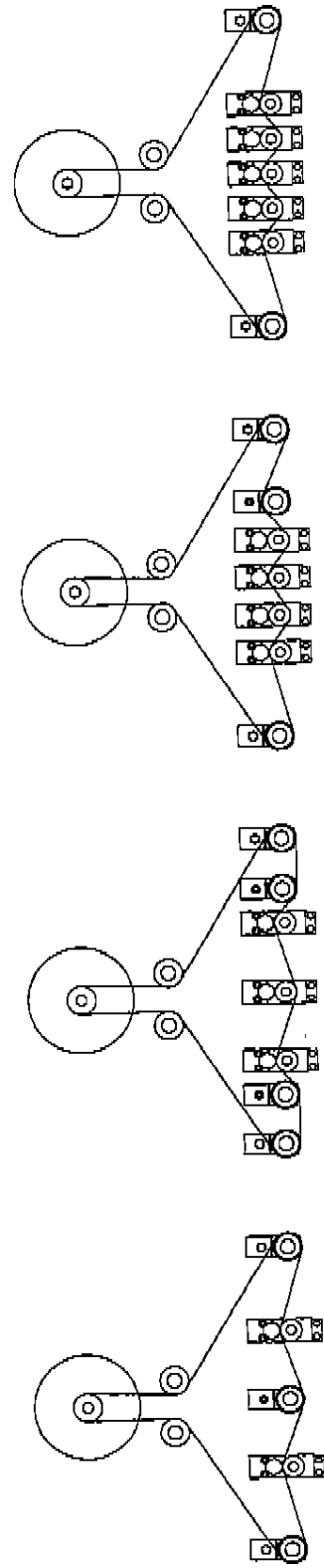

S-1781-46

HYDRAULIC POWER UNIT ASSEMBLY

H-378-1 (50/60 HZ 1 PHASE)

H-407-1 (50/60 HZ 3 PHASE)

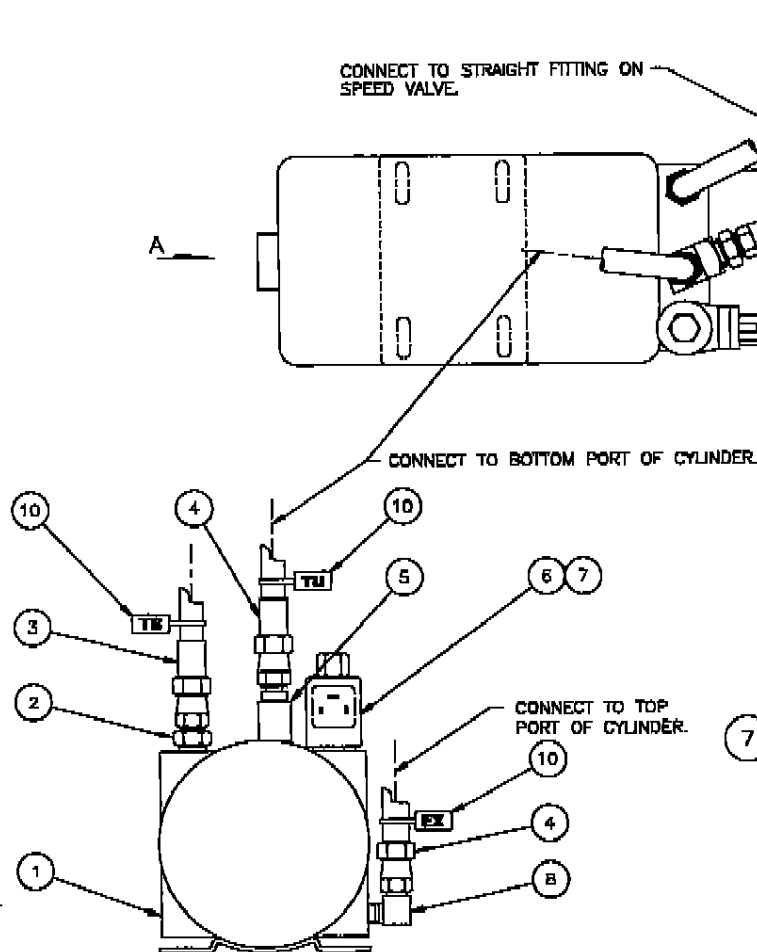

VIEW A
FITTINGS ROTATED FOR CLARITY

NOTES: ALL FITTINGS AND HOSES TO BE TIGHT
PUMP MOTOR TO BE WIRED FOR HIGH VOLTAGE, WITH A CLOCKWISE ROTATION.

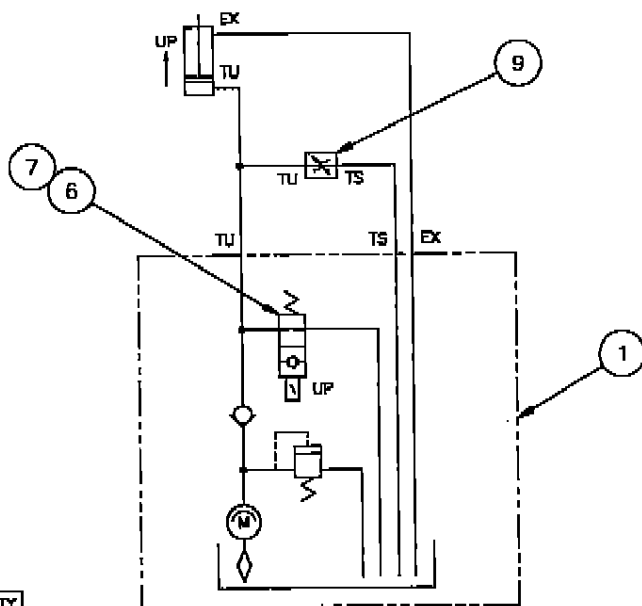

SCHEMATIC

NO.	PART NO.	DESCRIPTION OF ACCESSORIES	QTY
1	H-372	HYD. POWER UNIT - 208/230V 50/60C 1PH	1
	H-405	HYD. POWER UNIT - 50/60C 3PH	
2	H-241-6	ADAPTER - 3/8 NPT TO 9/16 TUBE	1
3	H-242-10	HYDRAULIC HOSE ASSEMBLY 35" LONG	2
4	H-242-41	HYDRAULIC HOSE ASSEMBLY 25" LONG	2
5	H-263-2	TEE	1
6	H-200-5	SOLENOID CARTRIDGE	REF
7	E-1069-17	COIL	REF
8	H-237-4	ELBOW - 1/4 NPT TO 9/16 TUBE	1
9	H-4771-1	TABLE SPEED ADJUSTMENT VALVE	REF
10	S-1684-5	TYRAP - IDENTIFICATION	4

REPAIR PARTS

- E-1600-43 ELECTRIC MOTOR (50/60 HZ 1PH)
- E-1600-89 ELECTRIC MOTOR (50/60 HZ 3PH)
- E-1069-17 COIL
- H-200-5 CARTRIDGE - SOLENOID
- HH-299-14 SEAL KIT
- H-451 PUMP KIT
- H-440 TANK - 1-1/2qt RESERVIOR
- H-439 'O' RING - TANK
- H-238-2 STRAINER
- H-287 FILLER/BREATHER

HYDRAULIC SEQUENCE OF OPERATION

NOTE: PLEASE SEE SECTION ON THE ELECTRICAL SEQUENCE OF OPERATION FOR MORE DETAILS

HYDRAULIC SEQUENCE OF OPERATION

- A. Pump relay is energized providing power to the hydraulic motor.

- B. Energize the UP solenoid (the table is sent up).

- C. De-energize the UP solenoid (the table is sent down).

HYDRAULIC SCHEMATIC REFERENCES (Drawing H-378 & H-407)

Once the pump relay (RL1) is energized, the hydraulic motor runs with the UP solenoid de-energized. This allows oil to flow through the UP solenoid valve (Item #6) and back to the tank. The table remains in the down position.

When the UP solenoid is energized, oil stops flowing through the UP solenoid valve (Item #6), and flows to the table up (TU) port of the table speed adjustment valve (Item #9) and to the table up (TU) port of the cylinder. Oil exits the table speed adjustment valve (Item #9) through the table speed (TS) port and then returns to the tank. The amount of oil that flows through the valve affects how much oil flows to the cylinder. This determines the speed of the cylinder piston. As the piston moves up, excess oil in the cylinder is forced out the excess (EX) cylinder port and back to the tank.

When the UP solenoid is de-energized, oil from the pump flows freely through the UP solenoid valve (Item #6) and back to the tank. This allows oil to flow out of the cylinder through the table up (TU) cylinder port, through the UP solenoid valve (Item #6), and back to the tank. Two springs force the piston down. The pump relay (RL1) remains energized.

BASIC MACHINE SCHEMATIC E-2384-1 REV A

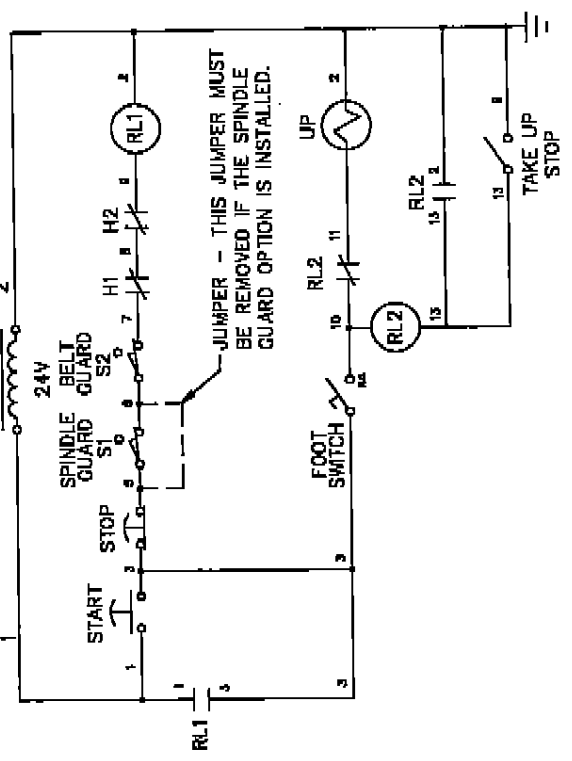
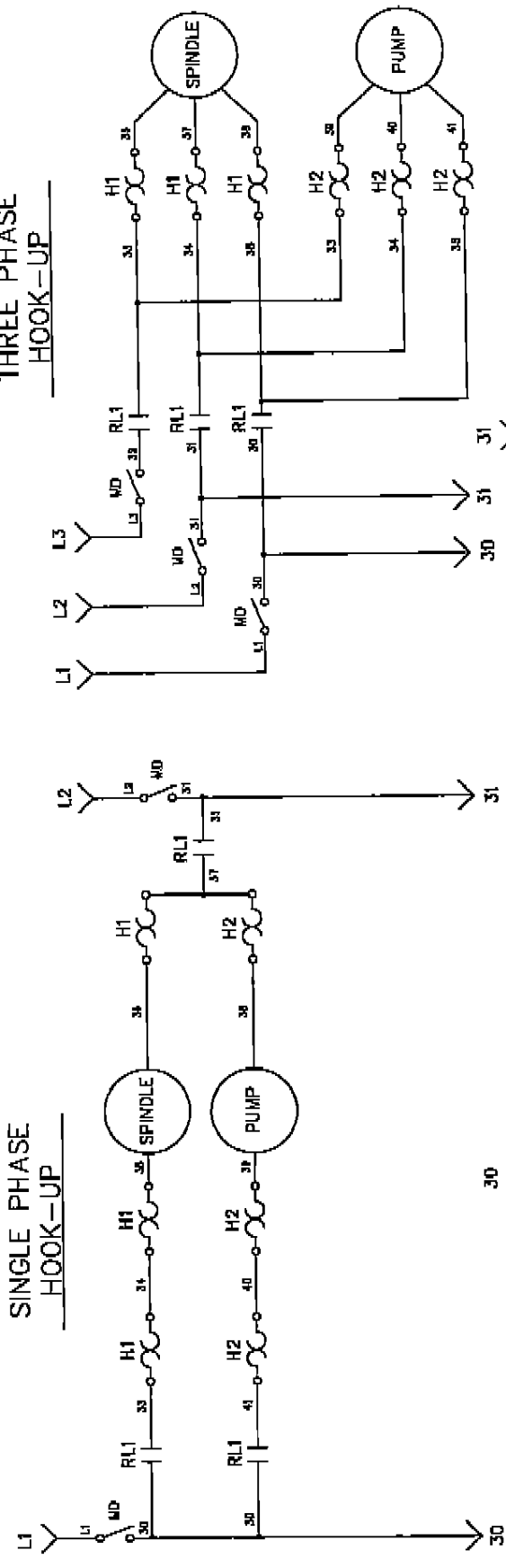

ELECTRICAL SEQUENCE OF OPERATION

NOTE: PLEASE SEE SECTION ON THE HYDRAULIC SEQUENCE OF OPERATION FOR MORE DETAILS

ELECTRICAL SEQUENCE OF OPERATION

A. Close the main disconnect switch (MD).

B. Press the ON button (START).

C. Press the foot switch (FOOTSWITCH).

ELECTRICAL SCHEMATIC REFERENCES (Drawing E-2384-1)

While the main disconnect switch MD is closed, power is brought to transformer T1, provided fuse F1 is conductive. Transformer T1 provides power to the hydraulic motor and spindle motor contactors RL1. The contactors are open and therefore the motors will not run. Opening the main disconnect switch MD at any time cuts power to transformer T1.

When the START switch is closed, the hydraulic motor and spindle motor relay coil RL1 will energize, provided interlock switches S1 and S2 are closed. Power is then supplied to the hydraulic and spindle motors. RL1 remains energized until the STOP switch or any interlock switch is opened.

While the FOOTSWITCH switch is closed, power is brought to the UP solenoid, which raises the table. When the table reaches the top, the TAKE UP STOP switch closes, causing relay coil RL2 to energize. While RL2 is energized, the UP solenoid becomes de-energized, which lowers the table. Opening the FOOTSWITCH switch de-energizes RL2 and the UP solenoid.

POWER PANEL ASSEMBLY
1PH 208/230 V 50/60 HZ
EE-2385-2

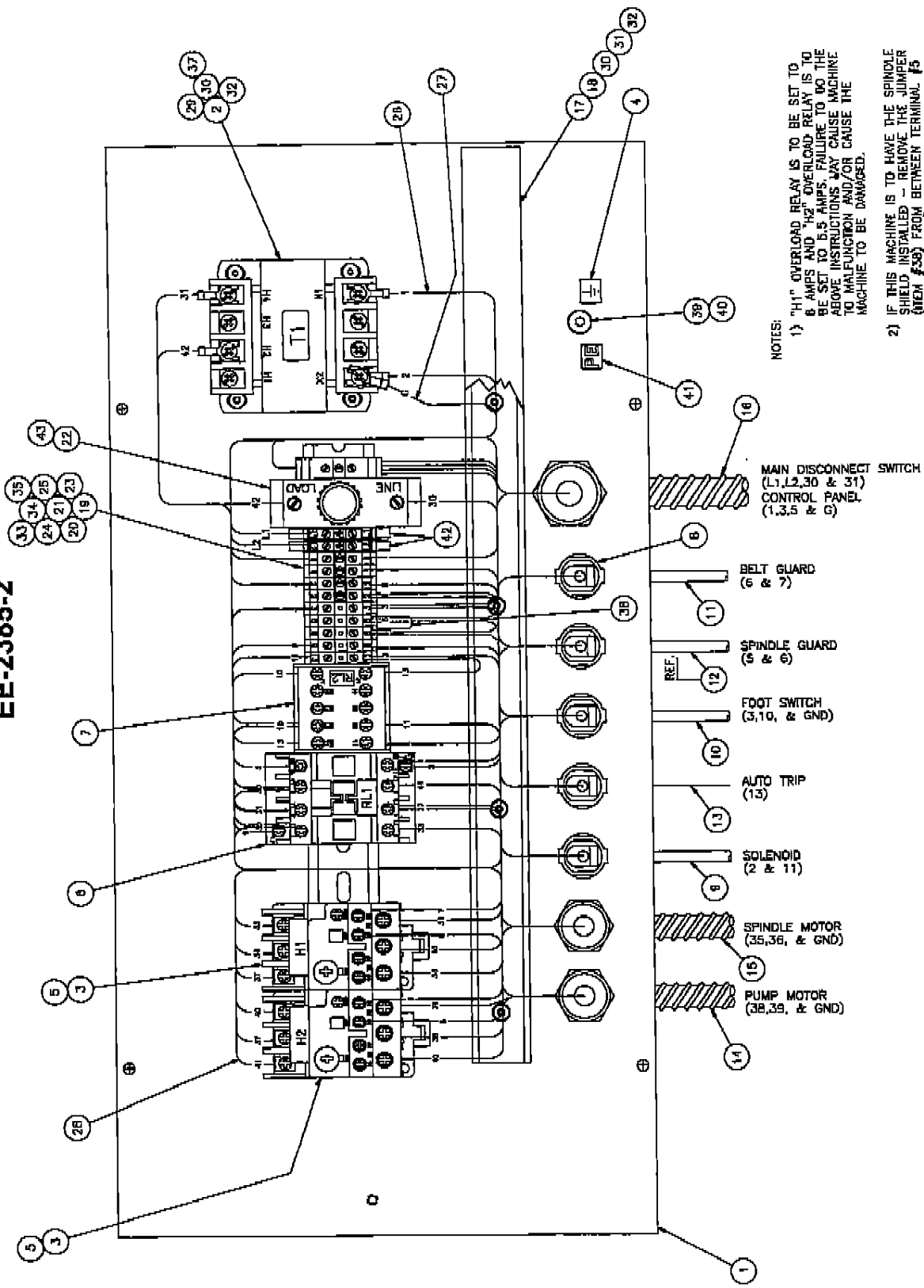

NOTES:
 1) "H1" OVERLOAD RELAY IS TO BE SET TO 6 AMPS AND "H2" OVERLOAD RELAY IS TO BE SET TO 6.5 AMPS. FAILURE TO DO THE ABOVE INSTRUCTIONS MAY CAUSE MACHINE TO MALFUNCTION AND/OR CAUSE THE MACHINE TO BE DAMAGED.
 2) IF THIS MACHINE IS TO HAVE THE SPINDLE SHIELD INSTALLED REMOVE THE JUMPER (WIRE #50) FROM BETWEEN TERMINAL #5 AND TERMINAL #6.

POWER PANEL ASSEMBLY
1PH 208/230 V 50/60 Hz
EE-2385-2

NO.	PART NO.	DESCRIPTION OF ACCESSORIES	QTY
22	E-1974-7	TERMINAL BLOCK - MIDGET FUSE HOLDER	1
23	E-2507-2	FIXED BRIDGE - 2 POLE	2
24	E-1356-107	LABEL - TERMINAL BLOCK	1
25	E-1356-108	LABEL - TERMINAL BLOCK	1
26	E-708-R	WIRE, #18 GA. RED MTW	AS NEEDED
27	E-708-G	WIRE, #18 GA. GREEN MTW	AS NEEDED
28	E-849-R	WIRE, #16 GA. RED MTW	AS NEEDED
29	E-1214-4	CONNECTOR, #8 INS. LOCKING FORK	5
30	H-8910-83204	SCREW - #8-32 X 1/2" BUT HD SOC CAP	8
31	H-7321-#8	WASHER - #8 USS FLAT	4
32	H-7330-#8	LOCKWASHER - #8 SHAKEPROOF	8
33	H-8910-102403	SCREW - #10-24 X 3/8" BUT HD SOC CAP	4
34	H-7330-#10	LOCKWASHER - #10	4
35	H-7321-#10	WASHER - #10 USS FLAT	4
36	S-1694	TYRAP (NOT SHOWN)	2
37	E-1584-51	LABEL - TRANSFORMER "T1"	1
38	E-709-R	WIRE - #18 GA. RED MTW 4" LONG	1
39	H-8910-403	SCREW - 1/4-20 X 3/8" BUT HD CAP	1
40	H-7324-B	WASHER - 1/4" INT. TOOTHLOCK	1
41	S-1781-45	LABEL - "PE" PROTECTED EARTH	1
42	E-2752	COVER - TERMINAL BLOCK, YELLOW	2
43	E-2308-9	FUSE - MIDGET, .3A T	1

NO.	PART NO.	DESCRIPTION OF ACCESSORIES	QTY
1	45119-1	PANEL - ELECTRICAL	1
2	E-1088-3B	TRANSFORMER - 208/230/480 50VA	1
3	E-2441	RELAY - OVERLOAD, 5.5A to .8A	2
4	S-1781-42	LABEL - MAIN GROUND	1
5	E-2445	BRACKET - OVERLOAD RELAY	2
6	E-2400-3	STARTER - 24V COIL (LC1D1210B7) (RL1)	1
7	E-2403	RELAY - RL2	1
8	S-1350-16	STRAIN RELIEF	5
9	EE-2396-1	CABLE ASSEMBLY - SOLENOID	1
10	E-875-4	FOOTSWITCH - SINGLE SWITCH	1
11	EE-2748-1	SWITCH ASM, BELT GUARD	1
12	EE-2750-1	SWITCH ASM, DRILL GUARD	REF
13	EE-2425	WIRE ASSEMBLY - AUTO TRIP	1
14	EE-2392	CONDUIT ASSEMBLY - PUMP MOTOR, 1PH	1
15	EE-2383	CONDUIT ASSEMBLY - SPINDLE MOTOR, 1PH	1
16	EE-2751	CONDUIT ASSEMBLY - CONT. PNL & MD SW	1
17	E-1429-13	WIRING DUCT (18" LONG)	1
18	E-2719-10	WIRING DUCT COVER (18-1/4" LONG)	1
19	E-1877-17	RAIL - MOUNTING (12-1/2" LONG)	1
20	E-2068-3	TERMINAL BLOCK - GROUND	1
21	E-2068-B	TERMINAL BLOCK - FEED THROUGH	11

POWER PANEL ASSEMBLY
3PH 208/230V 50/60Hz/460 V 60 Hz
EE-2386-2

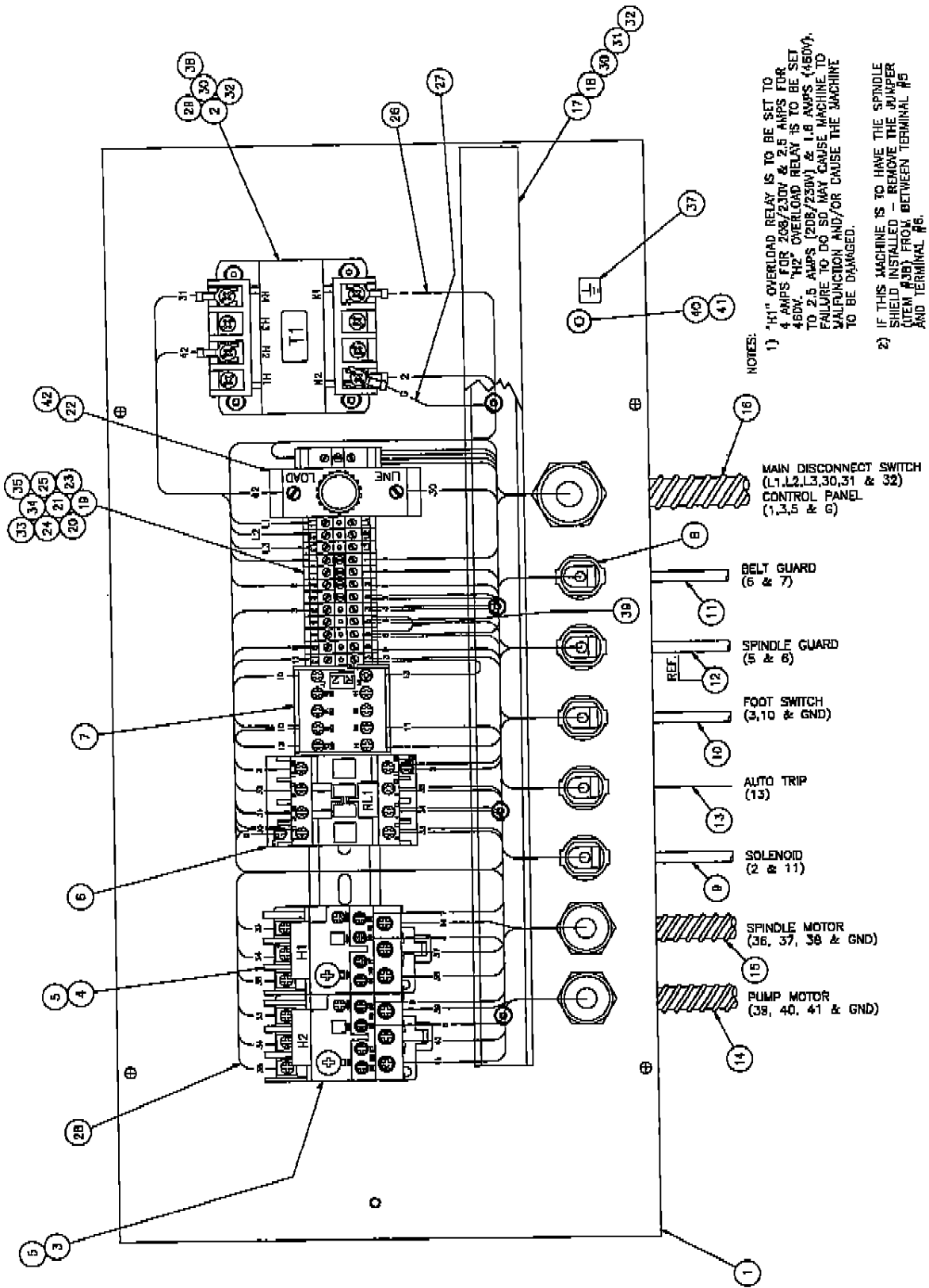

POWER PANEL ASSEMBLY
3PH 208/230V 50/60HZ/460 V 60 Hz
EE-2386-2

NO.	PART NO.	DESCRIPTION OF ACCESSORIES	QTY
21	E-2068-8	TERMINAL BLOCK - FEED THROUGH	12
22	E-1974-7	TERMINAL BLOCK - MIDGET FUSE HOLDER	1
23	E-2507-2	FIXED BRIDGE - 2 POLE	2
24	E-1366-105	LABEL - TERMINAL BLOCK	1
25	E-1368-106	LABEL - TERMINAL BLOCK	1
26	E-709-R	WIRE, #18 GA. RED MTW	AS NEEDED
27	E-709-G	WIRE, #18 GA. GREEN MTW	AS NEEDED
28	E-849-R	WIRE, #16 GA RED MTW	AS NEEDED
29	E-1214-4	CONNECTOR, #8 INS. LOCKING FORK	5
30	H-8910-B3204	SCREW - #8-32 X 1/2" BUT HD SOC CAP	8
31	H-7321-#8	WASHER - #8 USS FLAT	4
32	H-7330-#8	WASHER - #8 SHAKEPROOF	8
33	H-8910-102403	SCREW - #10-24 X 3/8" BUT HD SOC CAP	4
34	H-7330-#10	WASHER - #10 TOOTHLOCK	4
35	H-7321-#10	WASHER - #10 USS FLAT	4
36	S-1684	TYRAP (NOT SHOWN)	2
37	S-1761-42	LABEL - MAIN GROUND	1
38	E-1584-51	LABEL - TRANSFORMER "TI"	1
39	E-709-R	WIRE - #18 GA. RED MTW 4" LONG	1
40	H-8910-403	SCREW - 1/4-20 X 3/8" BUT HD CAP	1
41	H-7324-8	WASHER - 1/4" INT. TOOTHLOCK	1
42	E-2308-9	FUSE - MIDGET, 3/16A SLO-BLO	1

NO.	PART NO.	DESCRIPTION OF ACCESSORIES	QTY
1	45119-1	PANEL - ELECTRICAL	1
2	E-1089-38	TRANSFORMER - 208/230/460 50VA	1
3	E-2441-1	RELAY - OVERLOAD, (PUMP) 1.6A to 2.5A (H2)	1
4	E-2441-3	RELAY - OVERLOAD, (SPINDLE) 2.5A to 4A (H1)	1
5	E-2445	BRACKET - OVERLOAD RELAY	2
6	E-2400-3	STARTER - 24V COIL (LC1D1210B7) (RL1)	1
7	E-2403	RELAY - RL2	1
8	S-1350-16	STRAIN RELIEF	5
9	EE-2395-1	CABLE ASSEMBLY - SOLENOID	1
10	E-875-4	FOOTSWITCH - SINGLE SWITCH	1
11	EE-2749-1	SWITCH ASM. BELT GUARD	1
12	EE-2750-1	SWITCH ASM. DRILL GUARD	REF
13	EE-2425	WIRE ASSEMBLY - AUTO TRIP	1
14	EE-2392-1	CONDUIT ASSEMBLY - PUMP MOTOR, 3PH	1
15	EE-2393-1	CONDUIT ASSEMBLY - SPINDLE MOTOR, 3PH	1
16	EE-2751-1	CONDUIT ASSEMBLY - CONT. P.N.L. & MD SW	1
17	E-1429-13	WIRING DUCT (18" LONG)	1
18	E-2719-10	WIRING DUCT COVER (18-1/4" LONG)	1
19	E-1977-17	RAIL - MOUNTING (12-1/2" LONG)	1
20	E-2088-3	TERMINAL BLOCK - GROUND	1

POWER PANEL ASSEMBLY
3PH 380/415 V 50 HZ
EE-2369-2

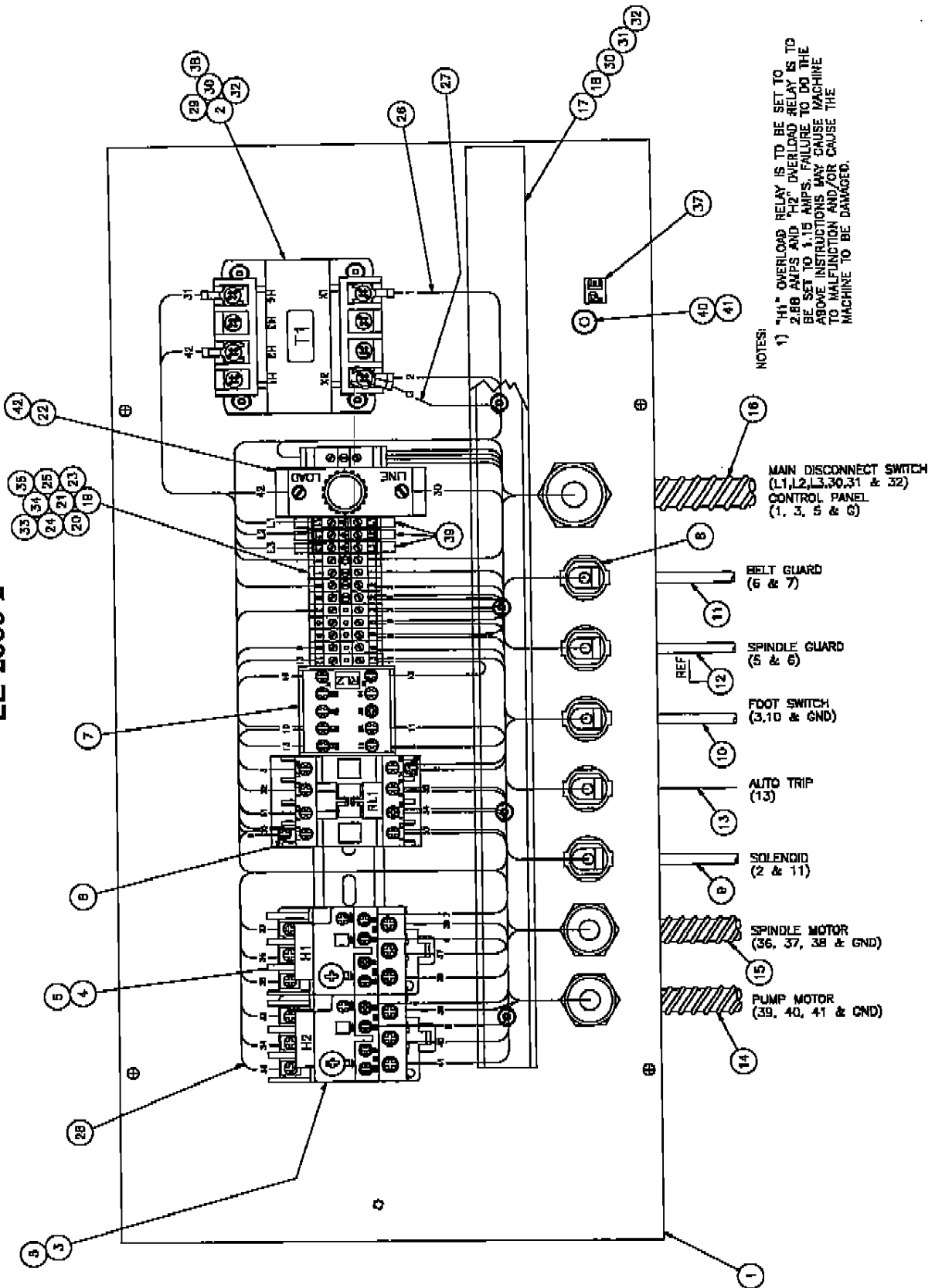

POWER PANEL ASSEMBLY
3PH 380/415 V 50 HZ
EE-2369-2

NO.	PART NO.	DESCRIPTION OF ACCESSORIES	QTY
22	E-1974-7	TERMINAL BLOCK - MIDGET FUSE HOLDER	1
23	E-2507-2	FIXED BRIDGE - 2 POLE	2
24	E-1358-105	LABEL - TERMINAL BLOCK	1
25	E-1358-108	LABEL - TERMINAL BLOCK	1
26	E-709-R	WIRE, #18 GA. RED MTW	AS NEEDED
27	E-708-G	WIRE, #18 GA. GREEN MTW	AS NEEDED
28	E-849-R	WIRE, #16 GA. RED MTW	AS NEEDED
29	E-1214-4	CONNECTOR, #8 INS. LOCKING FORK	5
30	H-8910-83204	SCREW - #8-32 X 1/2" BUT HD SOC CAP	8
31	H-7321-#8	WASHER - #8 USS FLAT	4
32	H-7330-#8	WASHER - #8 SHAKEPROOF	8
33	H-8910-102403	SCREW - #10-24 X 3/8" BUT HD SOC CAP	4
34	H-7330-#10	WASHER - #10 TOOTHLOCK	4
35	H-7321-#10	WASHER - #10 USS FLAT	4
36	S-1694	TYRAP (NOT SHOWN)	2
37	S-1781-45	LABEL - "PE" PROTECTED EARTH	1
38	E-1894-51	LABEL - TRANSFORMER "T1"	1
39	E-2752	COVER - TERMINAL BLOCK, YELLOW	3
40	H-8910-403	SCREW - 1/4-20 X 3/8" BUT HD CAP	1
41	H-7324-8	WASHER - 1/4" INT. TOOTHLOCK	1
42	E-2308-9	FUSE - MIDGET, 3A T	1

NO.	PART NO.	DESCRIPTION OF ACCESSORIES	QTY
1	45110-1	PANEL - ELECTRICAL	1
2	E-1089-39	TRANSFORMER - 380/415V 50HZ	1
3	E-2441-2	RELAY - OVERLOAD, (PUMP) 1A to 1.8A (H2)	1
4	E-2441-3	RELAY - OVERLOAD, (SPINDLE) 2.5A to 4A (H1)	1
5	E-2445	BRACKET - OVERLOAD RELAY	2
6	E-2400-3	STARTER - 24V COIL (LC1D121087) (RL1)	1
7	E-2403	RELAY - RL2	1
8	S-1350-16	STRAIN RELIEF	5
9	EE-2396-1	CABLE ASSEMBLY - SOLENOID	1
10	E-875-4	FOOTSWITCH - SINGLE SWITCH	1
11	EE-2749-1	SWITCH ASM, BELT GUARD	1
12	EE-2750-1	SWITCH ASM, DRILL GUARD	REF
13	EE-2425	WIRE ASSEMBLY - AUTO TRIP	1
14	EE-2392-1	CONDUIT ASSEMBLY - PUMP MOTOR, 3PH	1
15	EE-2393-1	CONDUIT ASSEMBLY - SPINDLE MOTOR, 3PH	1
16	EE-2751-1	CONDUIT ASSEMBLY - CONT. PNL. & MD SW	1
17	E-1429-13	WIRING DUCT (18" LONG)	1
18	E-2719-10	WIRING DUCT COVER (16-1/4" LONG)	1
19	E-1877-17	RAIL - MOUNTING (12-1/2" LONG)	1
20	E-2068-3	TERMINAL BLOCK - GROUND	1
21	E-2068-8	TERMINAL BLOCK - FEED THROUGH	12

DRILL HEAD ASSEMBLY 45152

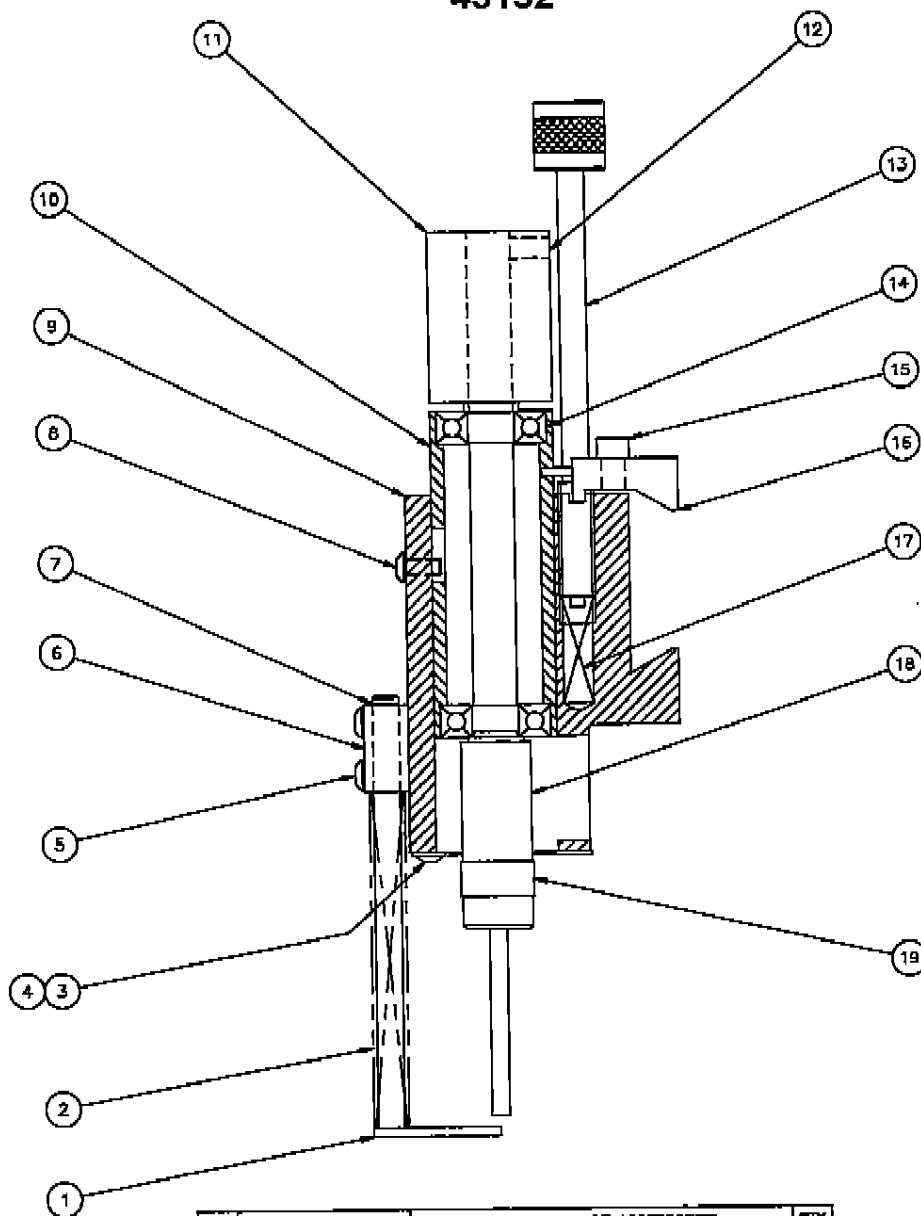

NO.	PART NO.	DESCRIPTION OF ACCESSORIES	QTY
1	45126	PRESSURE FOOT ASSEMBLY	1
2	4629-1	SPRING - PRESSURE FOOT	2
3	45158	COVER - HOUSING	1
4	H-6910-102403	#10-24 X 3/8 BUTTON HEAD CAP SCREW	2
5	H-6910-407	1/4-20 X 7/8 BUTTON HEAD CAP SCREW	2
6	45125	BLOCK PRESSURE FOOT	1
7	S-1518-37	RETAINING RING	2
8	H-6910-404	1/4-20 X 1/2 BUTTON HEAD CAP SCREW	1
9	45153	HOUSING	1
10	45156	SLEEVE	1
11	45154	PULLEY	1
12	H-6936-506	5/16-18 X 3/8 SOCKET SET SCREW	1
13	45157	SCREW - SPINDLE ADJUSTING	1
14	S-706	BEARING	2
15	H-6918-510	3/16-18 X 1-1/4 SOCKET HEAD CAP SCREW	2
16	45090	CLAMP - HOUSING	1
17	35048-4	SPRING	1
18	45155	SPINDLE	1
19	K-85	COVER - DRILL DRIFT HOLE	1

POWER PANEL LABEL 50/60 Hz REV A

⚠ CAUTION ¡PRECAUCION! ATTENTION ACHTUNG ⚠

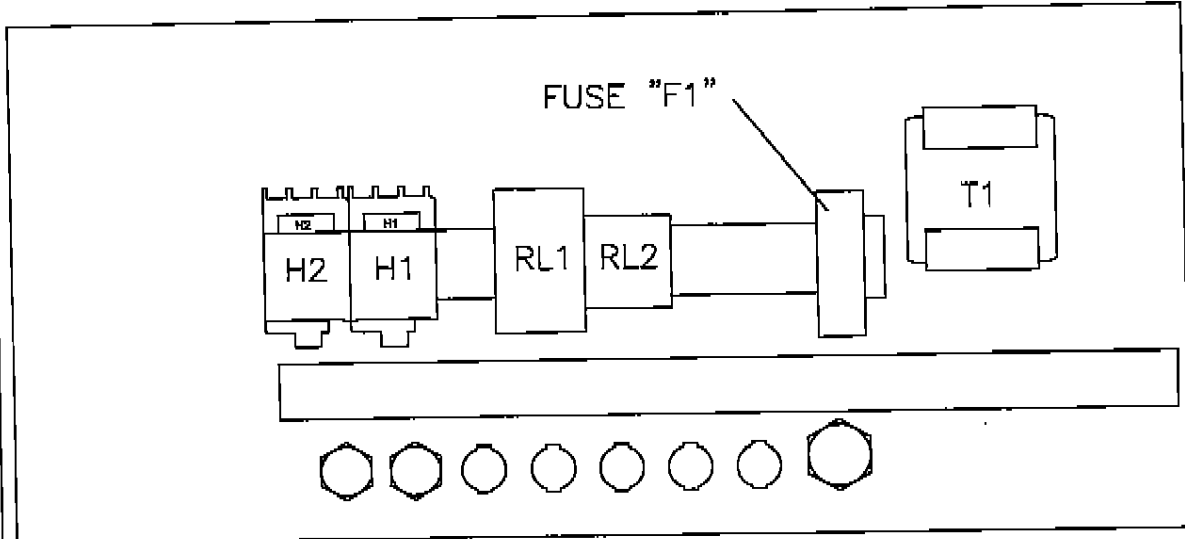

CAUTION: FIRE HAZARD, REPLACE ONLY WITH SAME TYPE AND RATING FUSE.



	VALUE CLASSEMENT CLASIFICACIÓN WERT	DIMENSION (INCHES)	PART NUMBER ARTICLE NUMBRE ARTÍCULO NÚMBRO TEIL ZAHL
F1	.3AMP T	13/32x1-1/2	E-2308-9

HEATER SWITCH SETTING SPECIFICATIONS CHART			
RELAY	PHASE	VOLTAGE	HEATER SWITCH SETTING
H1	SINGLE PHASE	208/230V	8 AMPS
H1	3 PHASE	208/230V	4 AMPS
H1	3 PHASE	460V	2.5 AMPS
H1	3 PHASE	380/415V	2.88 AMPS
H2	SINGLE PHASE	208/230V	5.5 AMPS
H2	3 PHASE	208/230V	2.5 AMPS
H2	3 PHASE	460V	1.6 AMP
H2	3 PHASE	380/415V	1.15 AMPS

MSS DRILL

S-1781-47

TWO HAND CONTROL OPTION A-4851-48

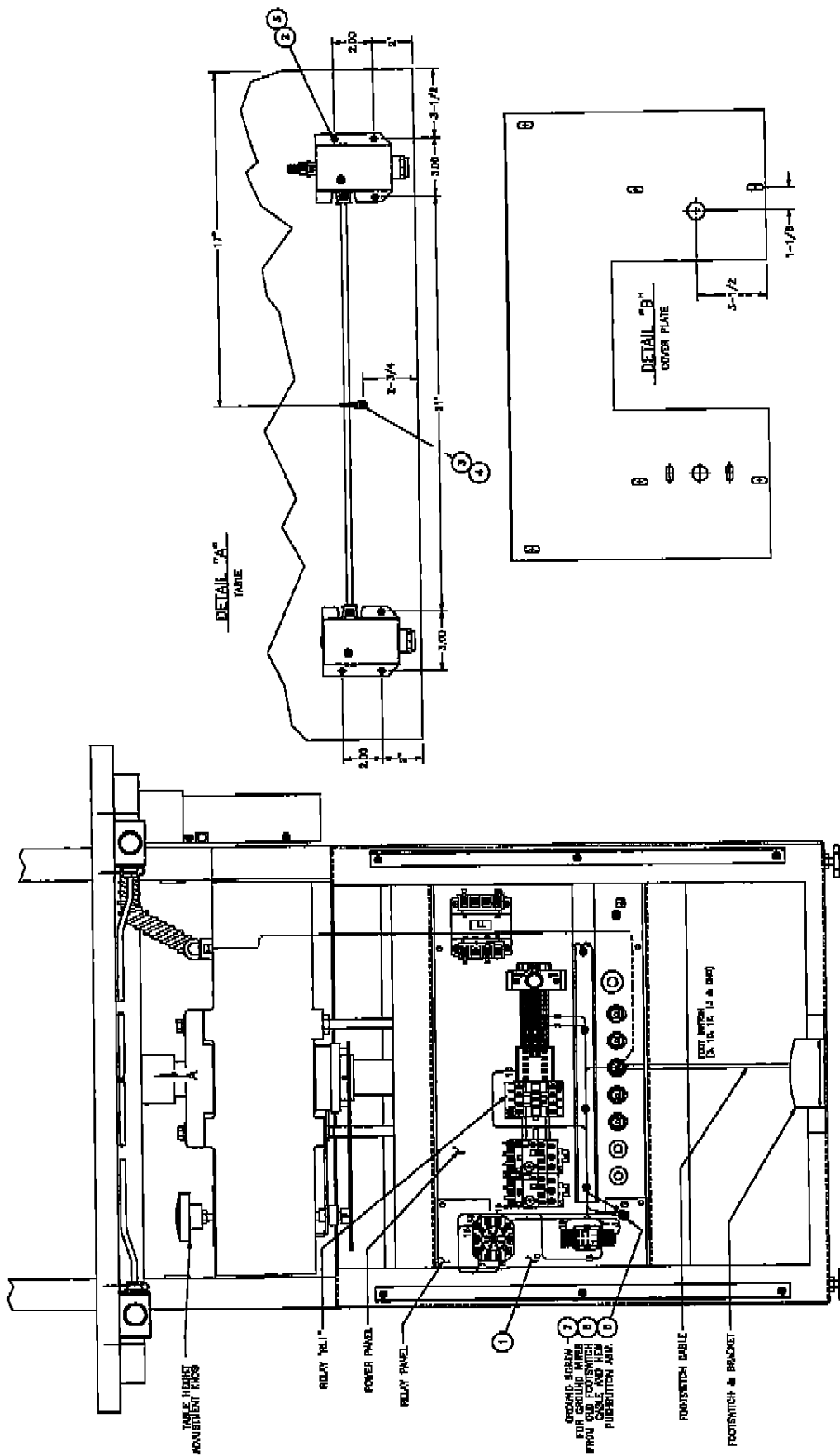

TWO HAND CONTROL OPTION A-4851-48

INSTALLATION INSTRUCTIONS: REMOVE POWER FROM THE MACHINE!

- 1) REMOVE THE FRONT OUTSIDE COVER TO THE MACHINE. (MACHINE IS SHOWN WITH COVERS REMOVED).
- 2) REMOVE THE TWO SCREWS FROM THE LEFT HAND SIDE OF THE POWER PANEL.
INSTALL THE (3) STAND-OFFS (ITEM #3), TWO INTO THE TWO MOUNTING HOLES AND ONE INTO THE EMPTY THREADED HOLE ON THE PANEL.
- 3) INSTALL THE RELAY PANEL ASSEMBLY (ITEM #1) AS SHOWN AND SECURE WITH THE SCREWS AND WASHERS REMOVED IN STEP #2 AND THE #10 SCREW AND WASHER SUPPLIED WITH THIS KIT.
- 4) REMOVE THE FOOT SWITCH AND FOOT SWITCH BRACKET. (DO NOT DISCONNECT THE FOOT SWITCH CABLE FROM THE POWER PANEL).
- 5) CUT THE FOOT SWITCH CABLE FLUSH WITH THE STRAIN RELIEF ON THE BACK OF THE FEET.
- 6) DISPOSE OF THE FOOT SWITCH, FOOT SWITCH BRACKET AND MOUNTING HARDWARE.
- 7) LOOSEN THE STRAIN RELIEF SCREW THAT SECURES THE FOOT SWITCH CABLE ON THE BACK OF THE POWER PANEL.
- 8) PULL THE FOOT SWITCH CABLE THROUGH THE STRAIN RELIEF TO THE FRONT OF THE PANEL.
- 9) STRIP THE FOOT SWITCH CABLE INSULATION BACK 6" ON THE LOOSE END, STRIP THE WIRE INSULATION BACK 3/8". ALL WIRES, CRIMP THE INSULATED FORK TERMINAL (ITEM #5) ONTO THE GREEN WIRE.
- 10) LABEL THE WIRES OF THE FOOT SWITCH CABLE AS FOLLOWS:
WHITE = #1
BLACK = #2
BLUE = #3
RED = #4

- 11) REMOVE THE COVER TO THE WIRE DUCT AND ROUTE THE FOOT SWITCH CABLE IN THE DUCT TOWARDS THE RELAY PANEL.
- 12) ATTACH THE FOOT SWITCH WIRES AS SHOWN.
- 13) FROM THE RELAY PANEL, LOCATE THE LOOSE WIRE #2. INSTALL THE WIRE INTO TERMINAL BLOCK #2 IN THE POWER PANEL (IN THE SAME TERMINAL WITH THE EXISTING WIRE #2).
- 14) ON THE UNDER SIDE OF THE TABLE, MARK AND DRILL (9) .161 DIA. HOLES 1/2" DEEP USING THE GIVEN DIMENSIONS.
- 15) USING THE SUPPLIED #10 X 5/8 SCREWS (ITEM #3) INSTALL THE PUSH BUTTON BOX ASSEMBLY - AS SHOWN.
- 16) INSTALL THE TY-RAP USING THE LAST #10 X 5/8 WOOD SCREW AND SECURE THE CABLE TO THE BOTTOM OF THE TABLE.
- 17) LOOSEN THE SET SCREW ON THE TABLE HEIGHT ADJUSTMENT KNOB AND SET THE KNOB ASIDE. REMOVE THE KNOB ON THE SHAFT AND SET ASIDE. REMOVE THE (6) BUTTON HEAD SCREWS AND SET THEM ASIDE. CAREFULLY REMOVE THE COVER PLATE.
- 18) ON THE COVER PLATE, LOCATE AND DRILL (1) 7/8 DIA. HOLE AS SHOWN IN DETAIL "B".
- 19) REINSTALL THE COVER PLATE AND TABLE HEIGHT ADJUSTMENT KNOB USING THE HARDWARE SET ASIDE IN STEP #17.
- 20) INSTALL THE LOOSE END OF THE CONDUIT FROM THE PUSH BUTTONS INTO THE HOLE IN THE TOP OF THE COVER PLATE.
- 21) BRING THE WIRES FROM THE CONDUIT DOWN TO THE STRAIN RELIEF WHERE THE FOOTSWITCH CABLE WAS REMOVED FROM IN STEP #3. ROUTE THE WIRES THROUGH THE STRAIN RELIEF AND TIGHTEN THE SCREW ON THE BACKSIDE. ROUTE THE WIRES THROUGH THE WIRE DUCT TO THE RELAY PANEL. INSTALLED IN STEP #3.
- 22) ATTACH THE WIRES FROM THE CONDUIT AS SHOWN. (THE GROUND WIRE FROM THE OLD FOOT SWITCH CABLE AND THE GROUND WIRE FROM THE NEW PUSH-BUTTON ASSEMBLY TO BE ATTACHED TOGETHER ON THE GROUND SCREW ON THE RELAY PANEL.
- 23) DOUBLE CHECK ALL WIRING AND REINSTALL THE WIRE DUCT COVER.
- 24) REINSTALL ALL COVERS!
- 25) APPLY POWER TO THE MACHINE.

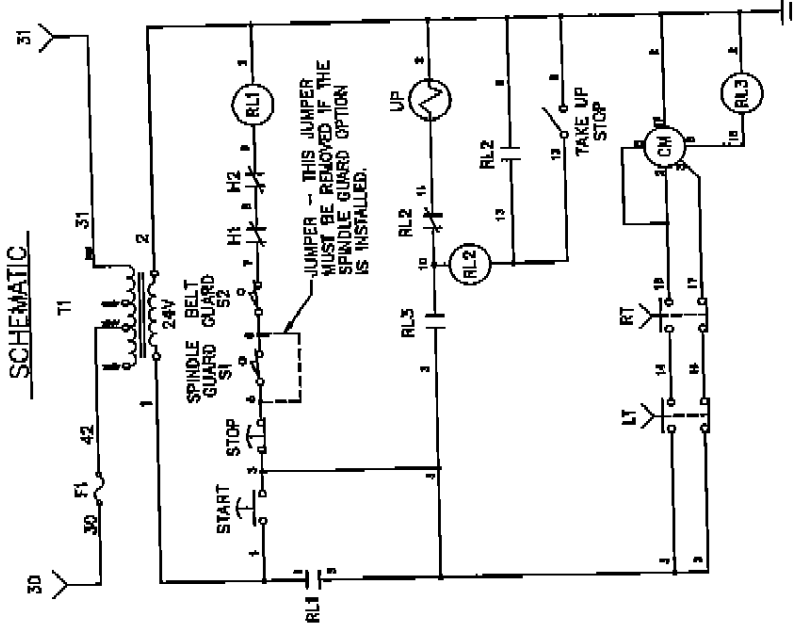

NO.	PART NO.	DESCRIPTION OF ACCESSORIES	QTY
1	EE-2848-1	PANEL ASSEMBLY - RELAY, 2 HAND CONTROL	1
2	EE-2847	BUTTON ASSEMBLY - DRILL, 2 HAND CONTROL	1
3	H-6982-1000	SCREWS - #10 X 5/8" WOOD	9
4	S-1504-2	TY-RAP - #10 MOUNT	1
5	E-1214-57	CONNECTOR, #8 INS. LOCKING FORK	1
6	H-6910-63204	SCREW, #8-32 X 1/2" BUT HD	1
7	H-6910-102404	SCREW - #10-24 X 1/2 BUT HD SOCKET CAP	1
8	H-7330-#10	WASHER, #10 EXT. TOOTHLOCK	1
9	E-1152-65	STAND-OFF - 3/4" LONG	3

BELT GUARD SWITCH REPLACEMENT KIT K-45181 (S/N: 975272 & BELOW ONLY)

FRONT COVER SWITCH DETAIL
EXPLODED VIEW

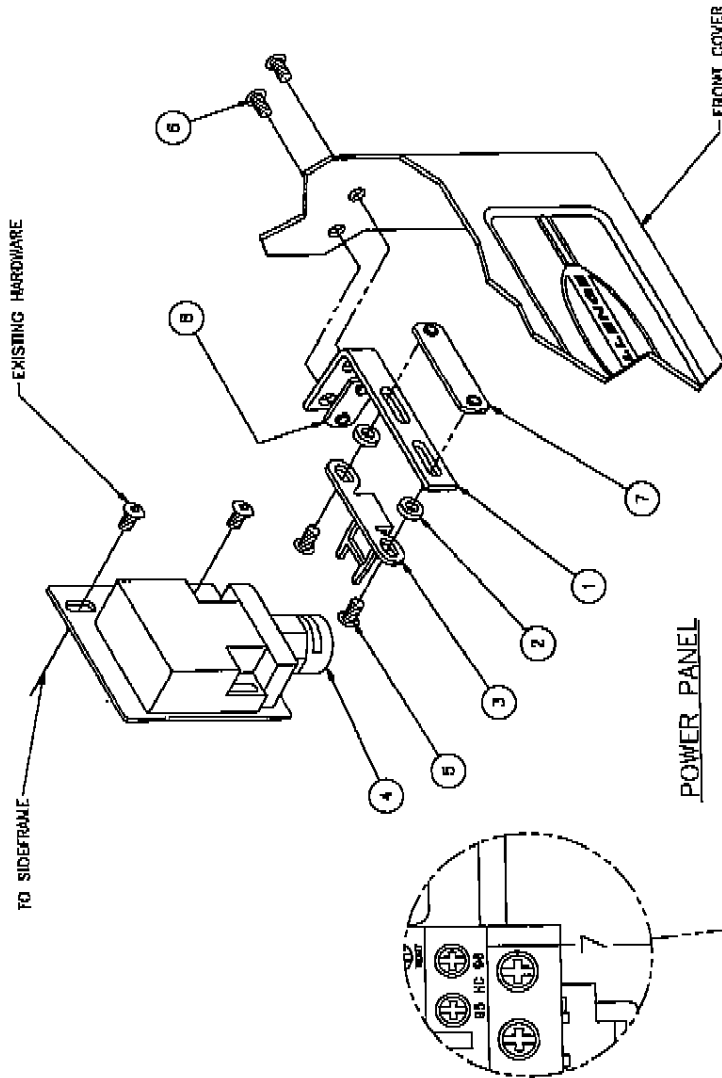

ASSEMBLY INSTRUCTIONS

1. DISCONNECT POWER TO MACHINE.
2. REMOVE EXISTING SWITCH ASSEMBLY AND ACTUATOR ASSEMBLY.
3. REMOVE WIRES FROM POWER PANEL AS SHOWN.
4. ASSEMBLE NEW ACTUATOR ASSEMBLY AS SHOWN AND ATTACH TO FRONT COVER.
5. ATTACH NEW SWITCH ASSEMBLY TO SIDEFRA...
6. ADJUST THE SWITCH ASSEMBLY AND/OR ACTUATOR ASSEMBLY SUCH THAT THE SWITCH IS ACTUATED SMOOTHLY AND COMPLETELY WHEN THE FRONT COVER IS CLOSED.
7. ROUTE THE SWITCH WIRES TO THE POWER PANEL AND ATTACH AS SHOWN. USE THE TYRAPS PROVIDED TO SECURE THE WIRES ALONG THE WAY.

NO.	PART NO.	DESCRIPTION OF ACCESSORIES	QTY
1	45173	BRACKET	1
2	E-1152-62	SPACER	2
3	45180	ACTUATOR	1
4	EE-2749-1	SWITCH ASSEMBLY	1
5	H-8918-102408	SCREW - #10-24 X 3/4 BRIT HD CAP	2
6	H-6818-102404	SCREW - #10-24 X 1/2 BLU FIB CAP	2
7	H-8418-102412	WELDNUT	1
8	H-8418-102408	WELDNUT	1
9	S-1684	TYRAP (NOT SHOWN)	2
10			

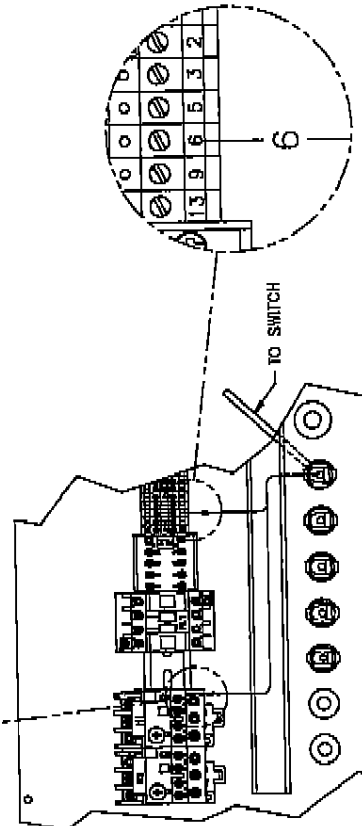

DRILL GUARD SWITCH REPLACEMENT KIT K-45182 (S/N: 975272 & BELOW ONLY)

SWITCH ASSEMBLY
EXPLODED VIEW

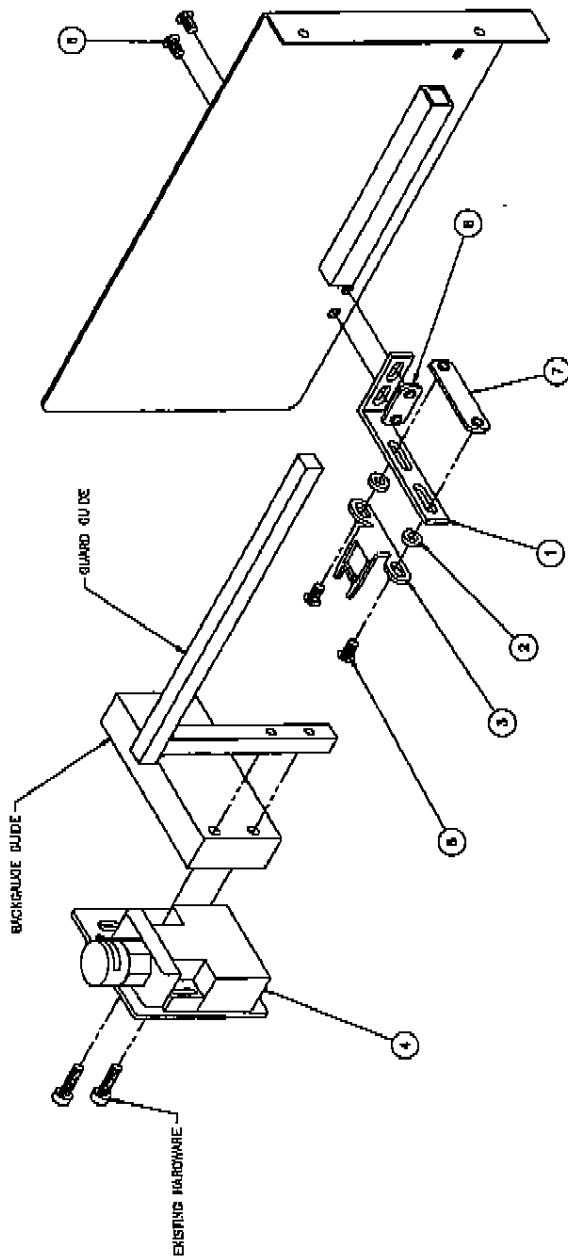

ASSEMBLY INSTRUCTIONS

1. DISCONNECT POWER TO MACHINE.
2. REMOVE EXISTING SWITCH ASSEMBLY AND ACTUATOR ASSEMBLY.
3. REMOVE WIRES FROM POWER PANEL AS SHOWN.
4. ASSEMBLE NEW ACTUATOR ASSEMBLY AS SHOWN AND ATTACH TO INSIDE OF THE DRILL GUARD AS SHOWN.
5. ATTACH NEW SWITCH ASSEMBLY TO BACKGAUGE GUIDE.
6. ADJUST THE SWITCH ASSEMBLY AND/OR ACTUATOR ASSEMBLY SUCH THAT THE SWITCH IS ACTUATED SMOOTHLY AND COMPLETELY WHEN THE FRONT GUARD IS CLOSED.
7. ROUTE THE SWITCH WIRES TO THE POWER PANEL AND ATTACH AS SHOWN. USE THE TYRAPS PROVIDED TO SECURE THE WIRES ALONG THE WAY.

POWER PANEL

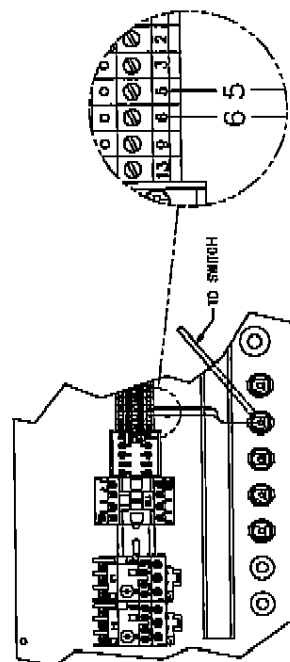

NO.	PART NO.	DESCRIPTION OF ACCESSORIES	QTY
1	45175	BRACKET	1
2	E-1152-52	SPACER	2
3	45180	ACTUATOR	1
4	EE-2750-1	SWITCH ASSEMBLY	1
5	H-6918-102406	SCREW - #10-24 X 3/4 BUT HD CAP	2
6	H-6918-102404	SCREW - #10-24 X 1/2 BUT HD CAP	2
7	H-6416-102412	WELDNUT	1
8	H-6416-102406	WELDNUT	1
9	S-1694	TYRAP (NOT SHOWN)	2
10			

SAFETY SYSTEM TESTS

Machine manufacturer _____ Model _____

Serial Number _____

Frequency of test: **THESE TESTS SHOULD BE PERFORMED AT THE BEGINNING OF EACH WORK DAY.**

Connect power to the machine, turn the main disconnect switch to the "on" position, and press the "on" button. Check both motors to see that they are operating.

Test #1: With the machine running, open the upper front cover. This should stop all motion. Close front cover.

Test #2: With the machine running, remove the front guard. This should stop all motion. Replace guard.

If the motors continue to run during either test, readjustment or repair is needed.

Please enter date and initials for both tests.

Date _____

Test 1 _____

Test 2 _____

Date _____

Test 1 _____

Test 2 _____

Date _____

Test 1 _____

Test 2 _____

Repairs	Initials of Repairer	Date
_____	_____	_____
_____	_____	_____
_____	_____	_____
_____	_____	_____
_____	_____	_____
_____	_____	_____
_____	_____	_____
_____	_____	_____
_____	_____	_____
_____	_____	_____

