

# GRAPHIC WHIZARD<sup>INC.</sup>

2283 Argentia Road, Suite 21; Mississauga, Ontario; Canada L5N 5Z2; Tel: (905) 858-7663 Fax: (905) 858-4419 Toll Free 1-800-265-3376  
Web Site: [www.graphicwhizard.com](http://www.graphicwhizard.com)

## GW 8000

### Reference Manual



Shown with optional second head

**GRAPHIC WHIZARD**  
2283 Argentia Road, Suite #21  
Mississauga, Ontario L5N 5Z2  
Phone # (905) 858-7663 Fax # (905) 858-4419  
Toll Free: 1-800-265-3376  
Web Site: [www.graphicwhizard.com](http://www.graphicwhizard.com)  
Version 99-04

# GW 8000 - Reference Manual

## Table of Contents

	<u>Page</u>
1.0 General Operation	2
2.0 Machine Assembly	3
2.1 Power Supply Instructions	3
2.2 Feed & Exit Trays	4
2.3 Numbering Heads	5
2.4 Optional Conveyor Outfeed Plate	6
2.5 Additional Switches and Controls	6
3.0 Operating Keyboard	7
3.1 Running a Job	8
3.2 Stopping a Job	10
3.3 Changing Programs	10
3.4 Programming a Job	11
3.5 The Batch Function	13
3.6 The Repeat Function	14
3.7 Motor Speed Control	14
4.0 Setting Up a Job	15
4.1 Aligning the Feed Tray Guides	15
4.2 Setting Feed Tire Pressure	15
4.3 Perforating/Slitting	17
4.4 Scoring	19
4.5 Idler Wheel Holders	19
4.6 Main Rollers	19
4.7 Installing Ink Pads	20
4.8 Locating the Numbering Heads	20
4.9 Setting Impression Control	21
4.10 Flatness of Impression	22
4.11 Stripper Assembly	23
5.0 Running a Job	24
5.1 Setting the Starting Number	24
5.2 Setting the Repeat Selector	25
5.3 Fanning	25
6.0 Maintenance	27
6.1 Numbering Heads	27
6.2 Machine Cleaning	27
6.3 Lubrication	28
6.4 Friction Feed	28
7.0 Troubleshooting	29
Friction Feeder	29
Print Quality	29
Registration	30
Numbering Heads	30

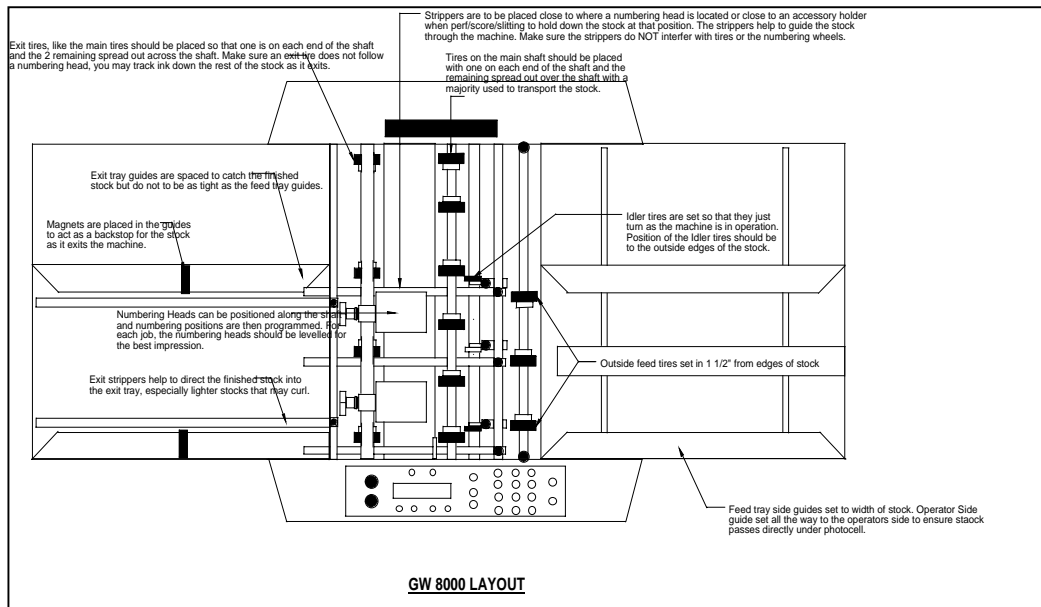

## 1.0 General Operation

The Model GW 8000 can number on single sheets (12# bond to 12 point card or 45 to 250 gsm paper) or multi-part carbonless forms (up to 10 parts) while simultaneously perforating, slitting and/or scoring. With proper set-up, 8000 sheets per hour (8.5" x 11" stock with one hit) can be quickly and identically processed. The Model GW 8000 is microprocessor controlled, making it easy to set up and program. It has the programmability to hold a maximum of 99 jobs with 10 hits and 1 job with 100 hits. These jobs can all be stored and recalled for future use. The unique friction feeder sends through one set at a time, even from the unglued side of a padded set. Perforations are done between the register board and main rollers, producing a straight perforation, slit or score, avoiding tail whip. Perforating wheels are offered in a wide range of teeth configurations and can be quickly changed using the retaining ring pliers supplied. A photocell recognises the lead edge of the sheet and the microprocessor stops the sheet at the specific location(s) where numbers are required. The numbering heads allow for a maximum of four pneumatically driven units. Pneumatics allows for non-stop, tireless operation. Finished stock is then delivered to a exit tray.

## 2.0 Machine Assembly

Remove and unpack all machine parts from the shipping carton.

### 2.1 Power Supply Instructions

Before connecting the power cord to a wall receptacle, make certain the supply voltage is what the machine has been set up for. The voltage is marked on the sticker containing the serial number of the machine. If there is any discrepancies, please call your dealer first before plugging in the machine.

The switch module is located behind the main operator side panel, directly underneath the register board. It also houses the main fuse.

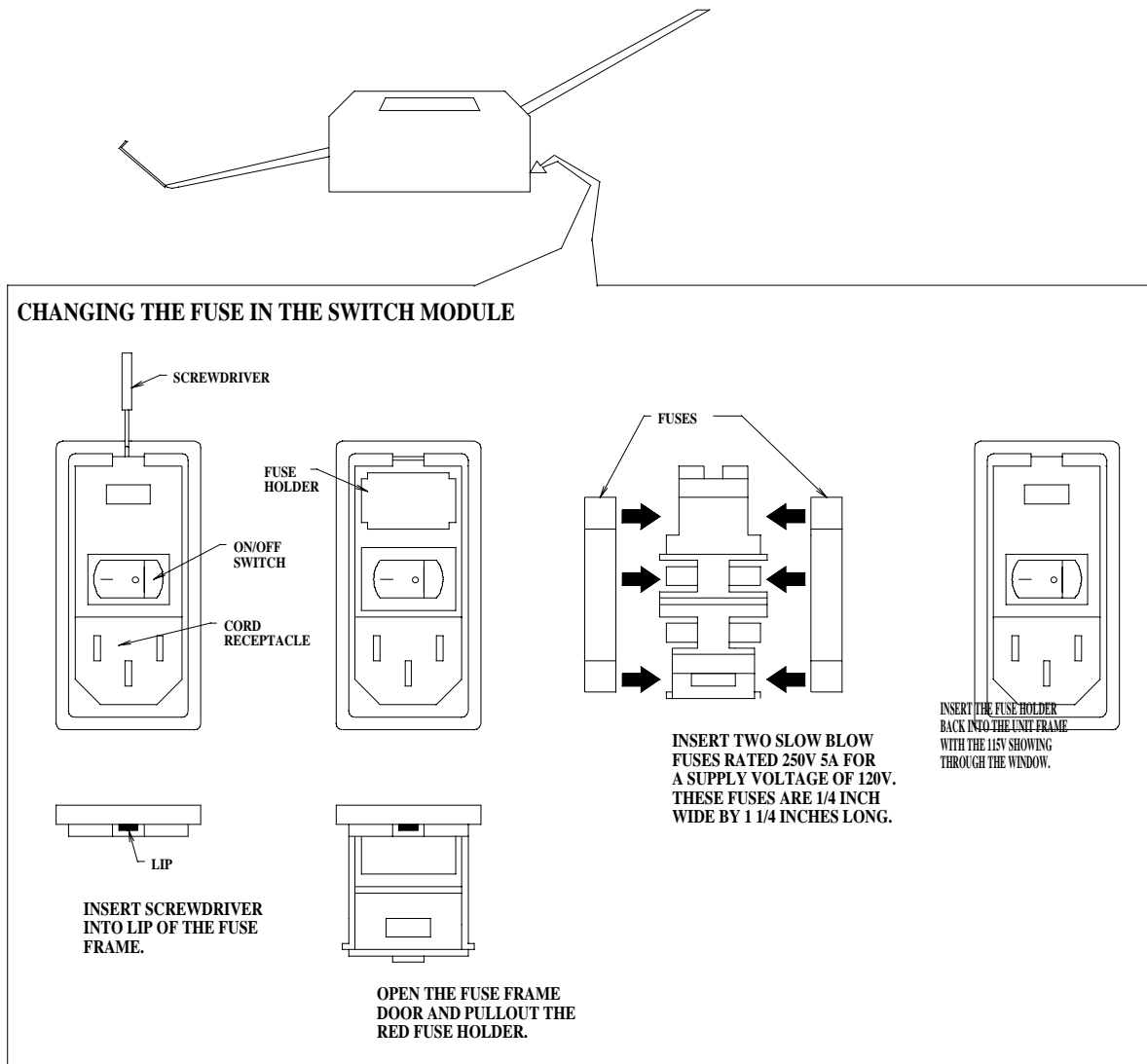

## 2.2 Feed and Exit Trays

The *feed* and *exit tray assemblies* are comprised of four components each: the *tray*, two *tray side guides* and a *centre slot cover* (see Figure 1a).

The *trays* sit in the machine on mounting pins inside the machine's side frames as shown in Figure 1b and 1c. The *trays* can be easily removed and stored elsewhere when not in use. Place the *tray side guides*, bottom flange towards the centre and the *centre slot cover* on the *tray* as shown in Figure 1a and screw on the nylon wing nuts to secure the pieces on the *tray*.

The *operator side tray guide* of both the *feed* and *exit tray* should be pulled all the way over to the

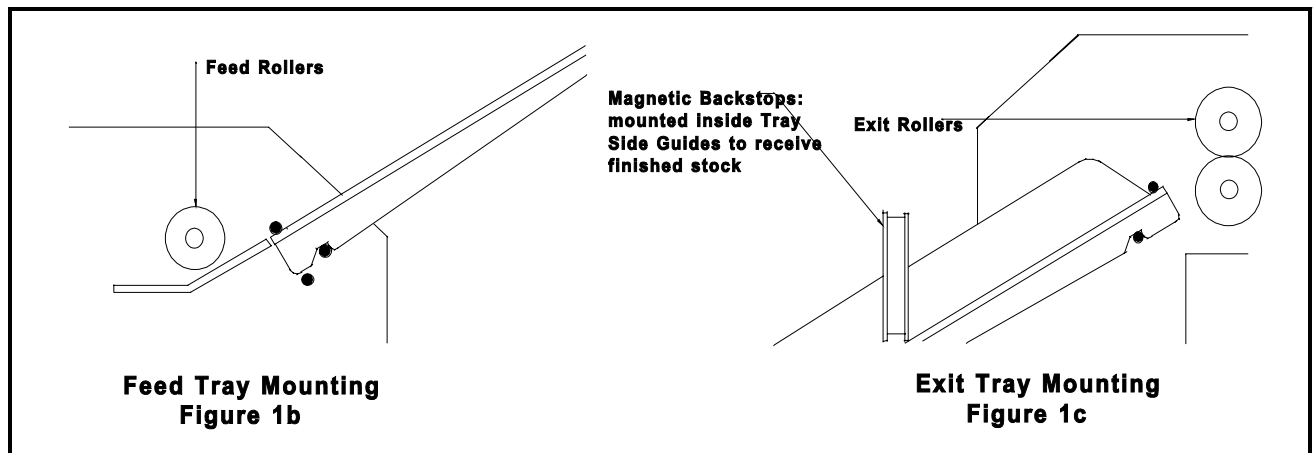
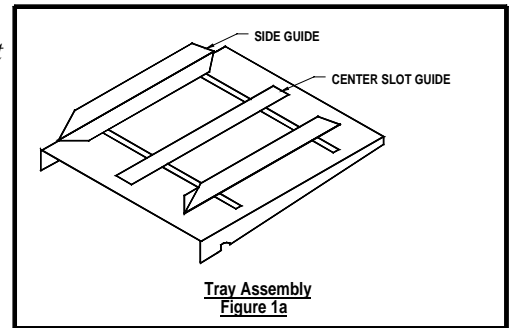

operator side before tightening its two wing nuts.

**Note:** It is critical that the *operator side tray guide* be moved all the way over to the operator side of the machine to ensure that the stock being processed through the machine passes directly underneath the *photocell*. If the stock does not pass directly underneath the *photocell*, the machines will not recognise sheets and the program being run will not be initiated.

Place a pile of the stock to be processed in the *feed tray* and use it to align the *non-operator side tray guide* to the pile. Allow a fraction of an inch so that the pile flows freely up and down the *tray* if released from the top. Set the *exit tray* in a similar manner, although the accuracy of the *non-operator side guide* position is not critical.

As a backstop to finished stock, there are two *magnets* included with the machine (unless equipped with the conveyor outfeed) that are set inside the *side tray guides* on the *exit tray*. Relative position of the *magnets* depends on the stock being processed, but the *magnets* should be set such that the stock does not slide down the *exit tray* too far, possibly causing sheets to get in uncollated order.

## 2.3 Numbering Heads

The *numbering heads* are already secured to the *drive unit* by two screws through the *numbering head mount block* as shown in *Figure 3*. The *drive unit* is then mounted to the *drive unit mount block* using the hand knob provided. While installing the *drive unit*, make sure the screw cap on the back of the *drive unit* fits in the cavity on the *drive unit mount block* so that the rubber plug provides some pressure against the screw cap. To do this, you may have to back out the *left/right pitch screw*. Plug in the cord

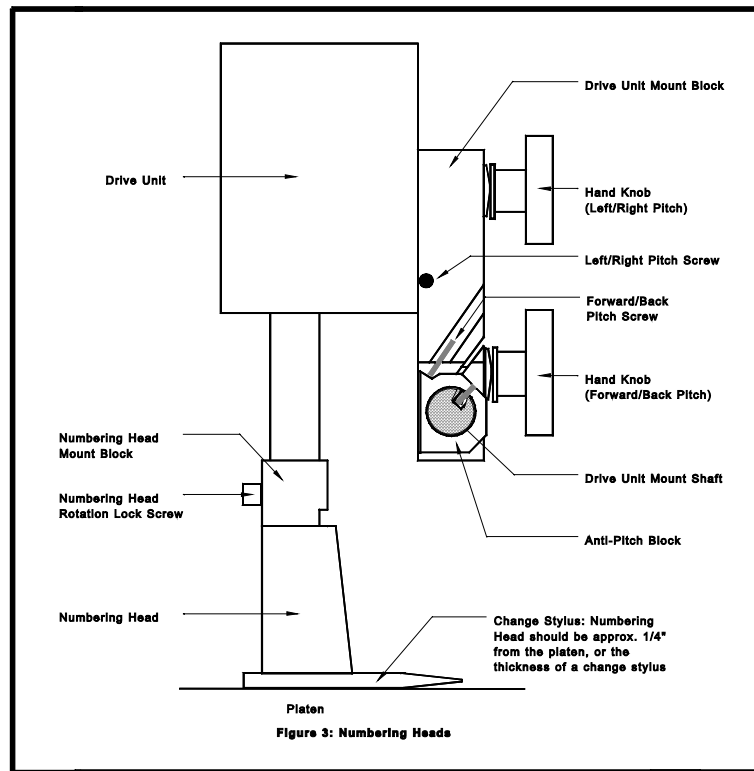

from the *drive unit* into the appropriate receptacle on the *non-operator side cover* (closest head to the closest receptacle). If your machine is equipped with more than one head, by convention, the *numbering head* and *drive unit* closest to the operator control panel will be referred to as head #1(**H1**) and the other will be head #2 (**H2**).

The height of the *numbering head* has been factory set and it is critical to the proper performance of the *drive unit* and *numbering head*. This distance is approximately 3" or the thickness of a *numbering wheel change stylus*. However, the *numbering head* must be levelled to ensure that the *numbering wheels* strikes the sheet square to provide a quality inked impression and a flat crash impression on carbonless sets. This will be discussed later (*Section 4.11*).

The *numbering heads* can operate through 360E. This is done by loosening the *numbering head rotation screw* (using the large hexdriver supplied) located on the front of the *numbering head mount block*. Once the screw is loose, the head is free to rotate. Tighten the screw once the desired position is achieved in order to prevent any movement during machine operation.

The standard *numbering head* is  $\frac{3}{16}$ " (4.5mm) Gothic style, reverse order, 6 digits with 2 drop wheels. The *numbering head* employs a pre-inked pad, which can be purchased in red or black. These inkpads will supply you with approximately 15,000 impressions. Uninked pads may be purchased if a different colour is required (*Note: any ink used must be a non-metal corrosive one, labelled numbering machine ink*).

The *numbering head* comes standard with six *numbering wheels* (a seventh *numbering wheel* is optional), the last two of which are drop wheels (this will be discussed later). The first 5 digits may be activated only. The 6th (or 7th) digit must be changed manually. Also available are letter prefix wheels (A-J;K-R;S-Z) and a  $\mu$  prefix wheel. Modifications are possible with new *numbering head* orders or by special order.

The *numbering heads* also have a repeat function. The *repeat selector* (see *Figure 4*) allows a number to be repeated from one to four times. By leaving the *repeat selector* in the "0" position, the number will not change when the head returns to the print position. Using the "0" position prevents you from having to re-set the starting number when you are programming a new job (this will be discussed later). Position "1" changes the number consecutively with each stroke and positions "2", "3" and "4" repeat the number 2, 3 or 4 times respectively. The repeat functions are achieved by a mechanical ratchet action in the *numbering head*. When trying to use these functions, you may have to cycle the *numbering head* manually in order to match the number of repeats on a page to the number positions on a page.

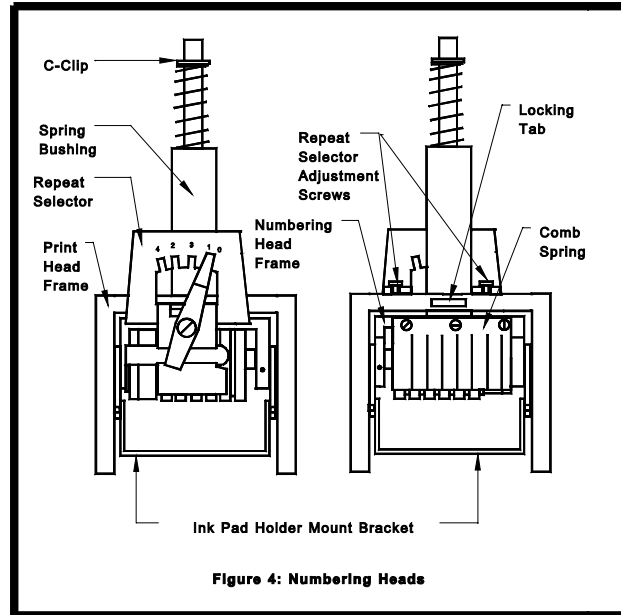

## 2.4 Optional Conveyor Outfeed Plate

The *conveyor outfeed plate* sits in the machine in the same fashion as the *exit tray*. Make sure that the spur gears mesh and do not force the *conveyor outfeed plate* into position. The *pile tray* is mounted on the end of the *conveyor outfeed plate*, with two Phillips screws and acts as a backstop for the finished stock.

## 2.5 Additional Switches and Controls

The main *on/off switch* is located under the *feed tray* beside the *main fuseholder* and *power cord*.

On the left-hand side of the *operating keyboard*, there are two potentiometer knobs that control the crash strength of the *numbering head*, known as *Impression Controls* and can be adjusted to best suit the requirements of the job. For example, you may require stronger crash numbering for carbonless sets than for single sheet bond paper. This adjustment can be done while the machine is stopped or running.

# 3.0 Operating Keyboard

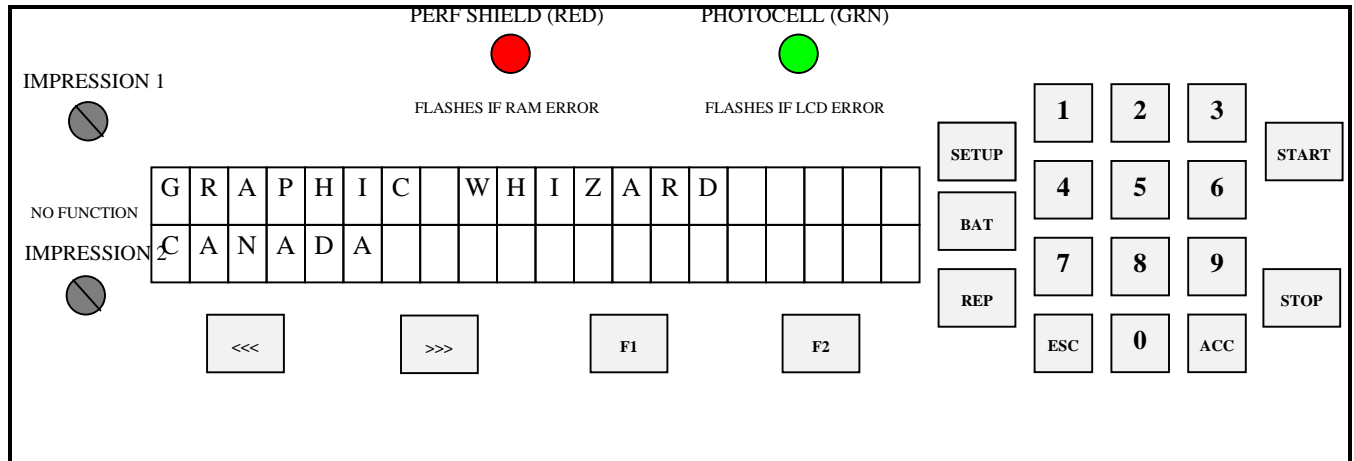

The *operating keyboard* is comprised of a *two line LCD display*, various buttons and two *Impression Controls* which consist of two potentiometer knobs that control the crash strength of the *numbering head*, and can be adjusted to best suit the requirements of the job. For example, you may require stronger crash numbering for carbonless sets than for single sheet bond paper. This adjustment can be done while the machine is stopped or running (see *Figure 5*).

The four buttons under the *LCD display* will perform whatever function is shown directly above them on the bottom line of the *LCD display*. They may not always be active (this is the case for the other buttons as well). Three specific function buttons (**SET UP**, **BAT**, **REP**) are situated beside the display. A numeric keypad, an '**ESC**' (escape), '**ACC**' (accept), '**START**' and '**STOP**' button rounds out the rest of the keyboard. The '**ESC**' button can be used at almost any time (except during actual running) in order to return to the previously viewed menu. The functions of the rest of the buttons will be discussed later in this section.

Once you have plugged the machine in, turn the *on/off switch* to the '*on*' position. The microprocessor does an internal system check and the above will flash on the screen.

### 3.1 Running a Job

The Idle Mode is displayed below. From this menu, you can change the motor speed, modify your paper count and select your program. In this menu you can also enter the Batch size (see 3.5)

#### DISPLAY:

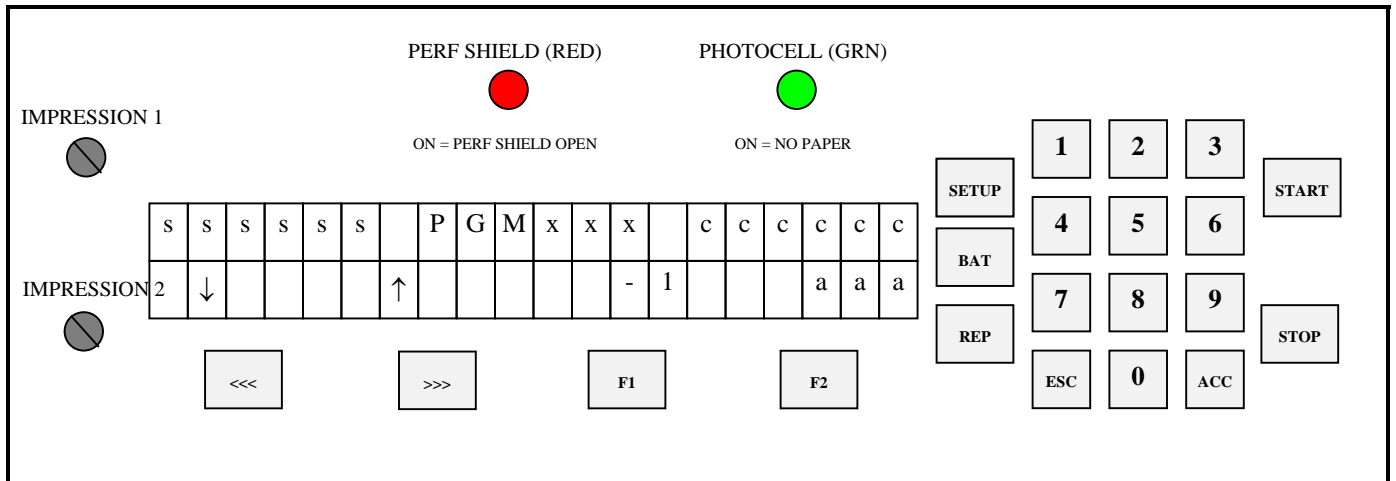

#### DISPLAY FUNCTIONS:

DISPLAY
sssss = motor speed bar graph PGMxxx = solenoid program in RAM cccccc = paper count ↓ = decrement motor speed ↑ = increment motor speed -1 = decrement paper count aaa = CLR -> clear paper count normally; aaa = BAT -> Enter <b>Mode - Set Batch Size</b> when batch mode is enabled

The <<</>>> will adjust the motor speed, **F1** will decrement the paper count, **F2** will clear the paper count but if it is already at **0** it will send you to the Batch mode (Section 3.5). **SETUP** will select a program (Section 3.3) and **START** will begin the job. You will now be in the Run Mode.

When the machine is first turned on, it defaults to Program 01 (PGM001), which is shown on the menu. Pressing the 'START' button will automatically begin Program 01. The *main operating menu* will change as the machine is running.

The Run Mode menu looks like this:

**DISPLAY:**

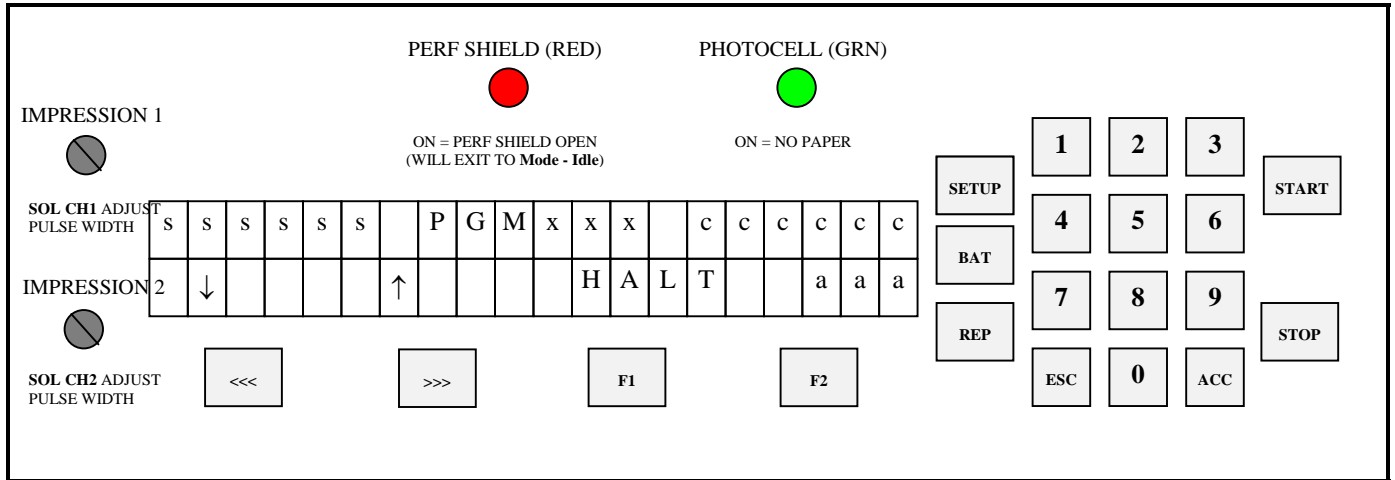

**DISPLAY FUNCTIONS:**

DISPLAY
<p>sssss = motor speed bar graph                      PGMxxx = solenoid program in RAM                      cccccc = paper count                      ↓ = decrement motor speed                      ↑ = increment motor speed                      HALT = motor emergency stop, exit to <b>Mode - Idle</b>                      aaa = CLR -&gt; clear paper count normally; aaa = BAT -&gt; Display current batch size when batch mode is enabled</p>

**KEYPAD FUNCTIONS:**

<<<	>>>	F1	F2	STOP	START
DECREMENT MOTOR SPEED	INCREMENT MOTOR SPEED	MOTOR EMERGENCY STOP Exit to <b>Mode - Idle</b>	IF BATCH SIZE IS ZERO <b>CLEAR PAPER COUNT</b> ELSE: <b>DISPLAY BATCH SIZE</b>	Complete numbering Eject current sheet Stop motor Exit to <b>Mode - Idle</b>	

ACC	ESC	SETUP	BAT	REP	
MOTOR EMERGENCY STOP Exit to <b>Mode - Idle</b>	MOTOR EMERGENCY STOP Exit to <b>Mode - Idle</b>	MOTOR EMERGENCY STOP Exit to <b>Mode - Idle</b>	IF BATCH SIZE IS ZERO <b>MOTOR EMERGENCY STOP</b> Exit to <b>Mode - Idle</b> ELSE: <b>DISPLAY BATCH SIZE</b>	MOTOR EMERGENCY STOP Exit to <b>Mode - Idle</b>	

DIG 0-9
MOTOR EMERGENCY STOP Exit to <b>Mode - Idle</b>

### 3.2 Stopping a Job

Here are methods of stopping the machine.

1. Once the program is running, there are several built in safety emergency stops. Pressing the **STOP** button, **any of the digits 0-9, F1, STOP, ACC, ESC, REP**, and if the Batch size is 0, **BAT** will cause the machine to finish the stock it is currently working on, move the next stock into the starting position and then stop the motor. This automatically sends you into Idle Mode.
2. If you want to stop the machine while stock is still left in it, simply hold on to the stock in the *feed tray*. After about one second, the machine will automatically stop (since it is no longer seeing any new sheets). This is how it also stops when all of the stock in the *feed tray* is gone.

### 3.3 Changing Programs

The GW 12000 allows you several choices in programming:

- PROGRAM 00 = Perf/score, automatically turns the numbering heads off.  
PROGRAM 01 – 99 = Allows for a maximum of 10 hits per head.  
PROGRAM 100 = Allows for a maximum of 100 hits per head.

Whenever you wish to change programs, the *LCD display* must be in Idle Mode (Section 3.1) press the '**SET UP**' button. The following screen will appear:

DISPLAY:

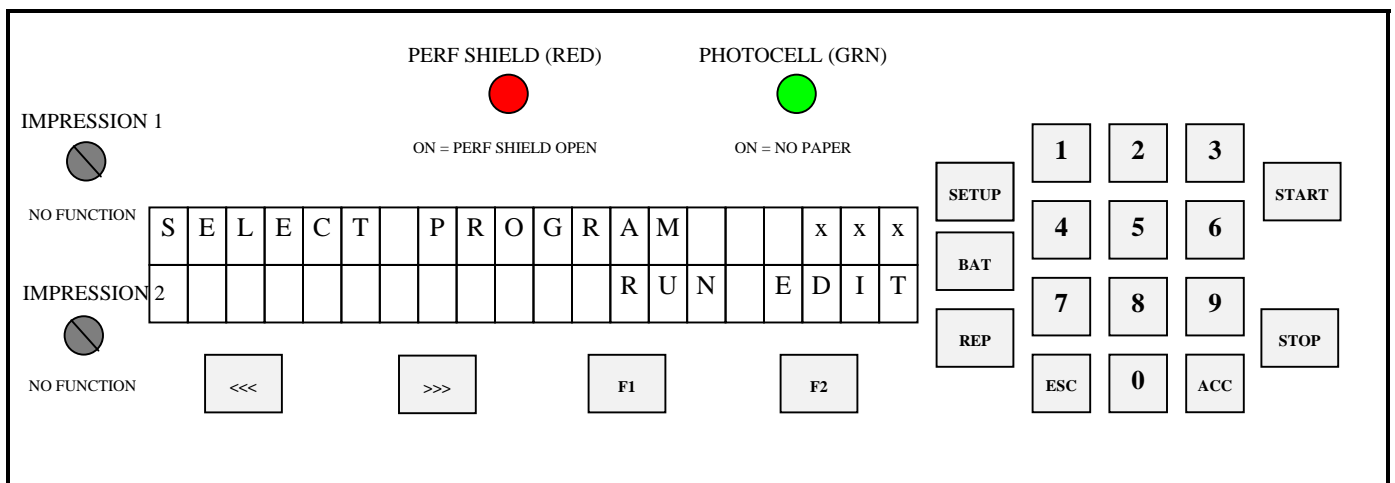

Once you select the program number desired, you may either '**RUN**' the existing program or '**EDIT**' it by pressing the corresponding function key (**F1** to RUN & **F2** to EDIT).

If **RUN** is selected, the machine will to exit to Idle Mode where you press **START**. The **ESC** key will also return to Idle Mode in case you wish to change the counter before beginning a job.

### 3.4 Programming a Job

If you wish to program a job, EDIT an existing program, press **F2**. After selecting **EDIT**, if the program already exists, the machine will ask whether you would like to erase it, start new ('NEW') or modify it ('MOD').

#### DISPLAY:

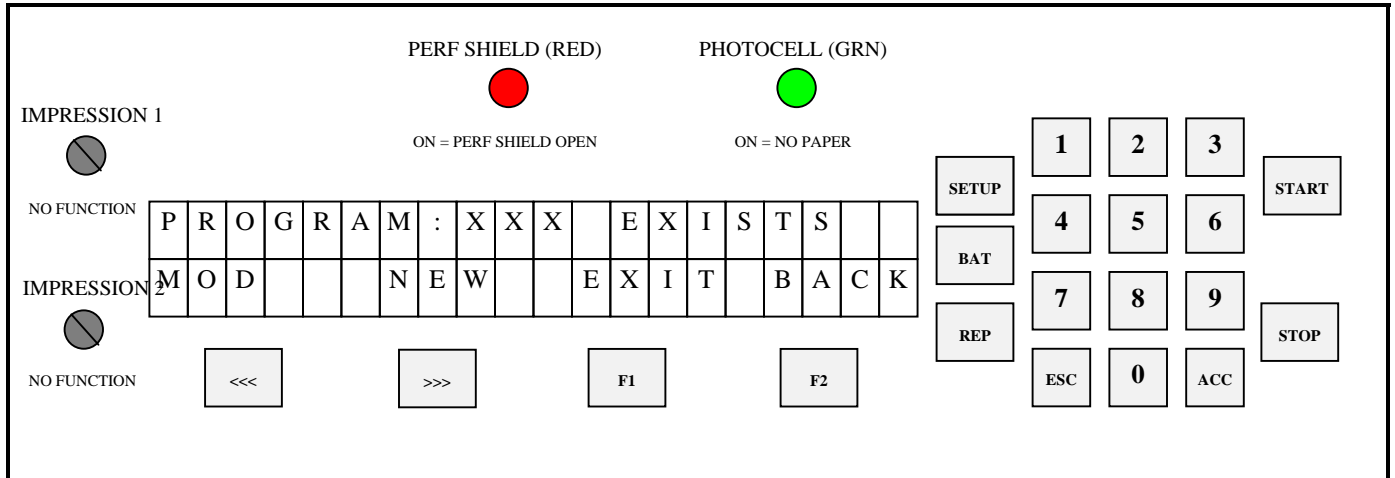

This selection is done with the corresponding function key (<<< and >>> respectively).

When modifying a program, previously programmed hits can be removed from the program while additional hits may be added.

Once you make your selection, the machine will instruct you to 'INSERT PAPER/ PRESS START'. The *LCD display* will then show the following:

#### DISPLAY:

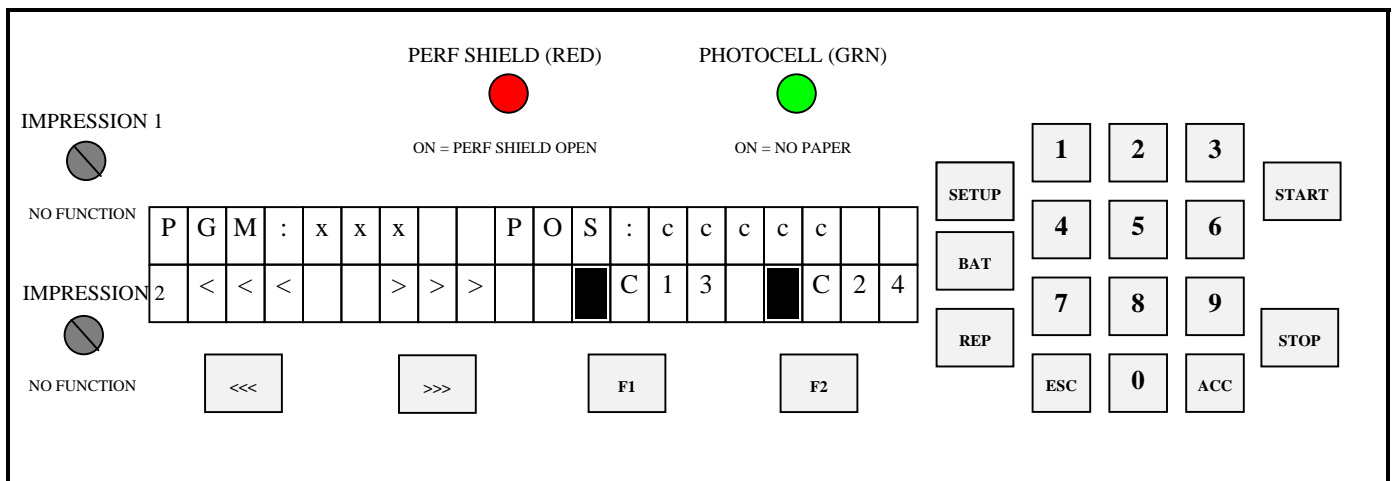

+

#### DISPLAY FUNCTIONS:

DISPLAY	
xxx	= solenoid program number
cccc	= current paper position in motor steps from paper lead edge
<<<	= motor moves in forward direction
>>>	= motor moves in backward direction

= full block character displayed when hit programmed

C1 = solenoid channel 1 head 1

3 = solenoid channel 1 head 2 = SOL3

C2 = solenoid channel 2 head 1

4 = solenoid channel 2 head 2 = SOL4

The sheet you inserted is automatically moved to position '75'. Position '0' is the lead edge of the sheet passing the photocell. Position '75' is the first location that an entire number will print on the paper. (*Note: Each step represents approximately  $\frac{1}{50}$ th of an inch.*)

The first two function keys step the paper either forward or backward (*Note: you cannot back the sheet back further than position '75'*). The other two function keys fire either head #1 or head #2. Once a head fire button has been pressed, the *numbering head* will fire and the *LCD display* will light up with one solid bar around the corresponding head fired (eg. ■C1).

In a four head system, heads 1&3 work together and heads 2&4 respectively. To activate heads 1&3 at any position press "F1" head 1 will fire and ■C1 will appear on the display press "3" on the keypad and head 3 will fire and ■C13 will appear. To activate head 2&4 you must press the number "4" on the keypad and ■C24 will appear on your display.

Configured, we can have in any one program, with a four head machine, a combination of, at any one time; heads 1&2&3&4, 1&3, 2&4, 1, 2. **Heads 3&4 cannot activate on their own.**

If the number is not in the position desired, simply press the function button again to toggle off the hit, otherwise continue moving up or down the sheet (the hit is automatically saved). This procedure can be repeated until the number is in the correct location. The page can be stopped a maximum of 15 times where you may program head #1 or head #2 or both heads to fire.

Once all numbers desired have been programmed, simply press the 'ACC' button and the sheet will be discharged from the machine. The next sheet will be forwarded to step '75' (if there is another sheet already in the *feed tray*) or you will be instructed to 'INSERT PAPER/PRESS START'. The *LCD display* will return to Idle Mode and you are set to run the job. Simply press the 'START' button to begin.

### 3.5 The Batch Function

Pressing the 'BAT' key before running a program will enter the batch menu.

**FUNCTION:**

1. Allows user to set or clear the batch size, max. batch size = 999999
2. Sets a new batch size by pressing <ACC>. The paper count and batch quantity are reset to 0.

**DISPLAY:**

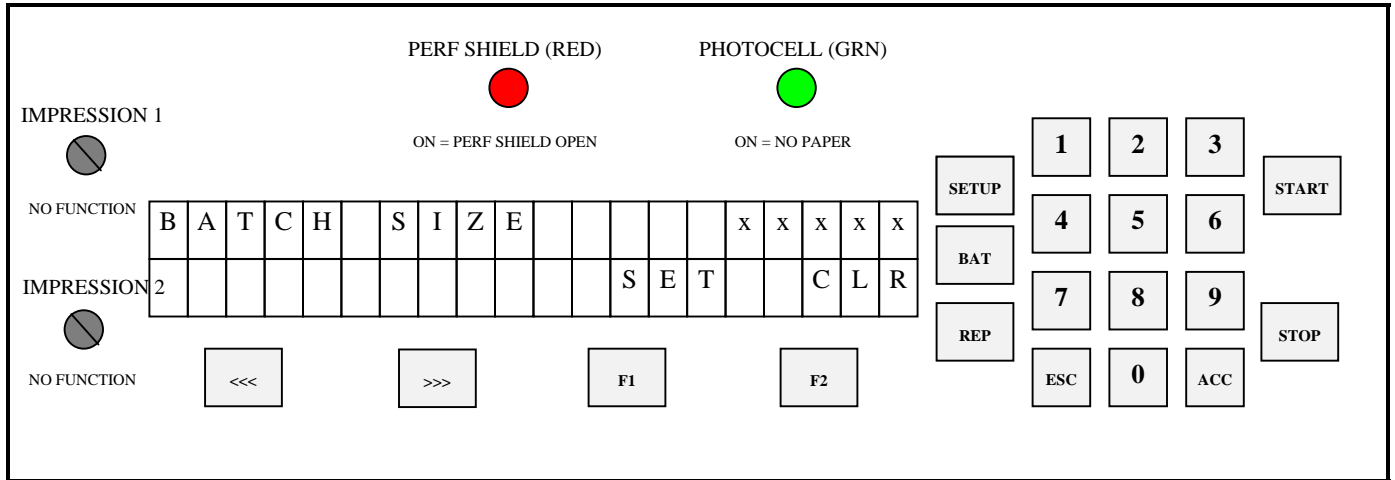

**DISPLAY FUNCTIONS:**

DISPLAY
xxxxx = batch size
SET = sets the batch size
CLR = sets the batch size to zero

At this point you may select the size of the batch desired by entering the desired batch size through the *keypad*. Press the 'ACC' key when the quantity desired has been chosen. Press the 'F2' key (CLR) if you wish to clear a quantity entered to disengage the batch function. Once again, the 'ESC' key will return you back to the *main operating menu* without activating the batch function. Pressing "F1" will reset the paper count and batch quantity.

When running a job with the batch function, the machine will stop after the last sheet has been processed, leaving the sheet partially in the *exit rollers*, allowing you to insert a slip sheet. The *LCD display* will then show the number of batches completed.

**FUNCTION:**

1. Displays the number of batches that have been completed of Batch Size

**DISPLAY:**

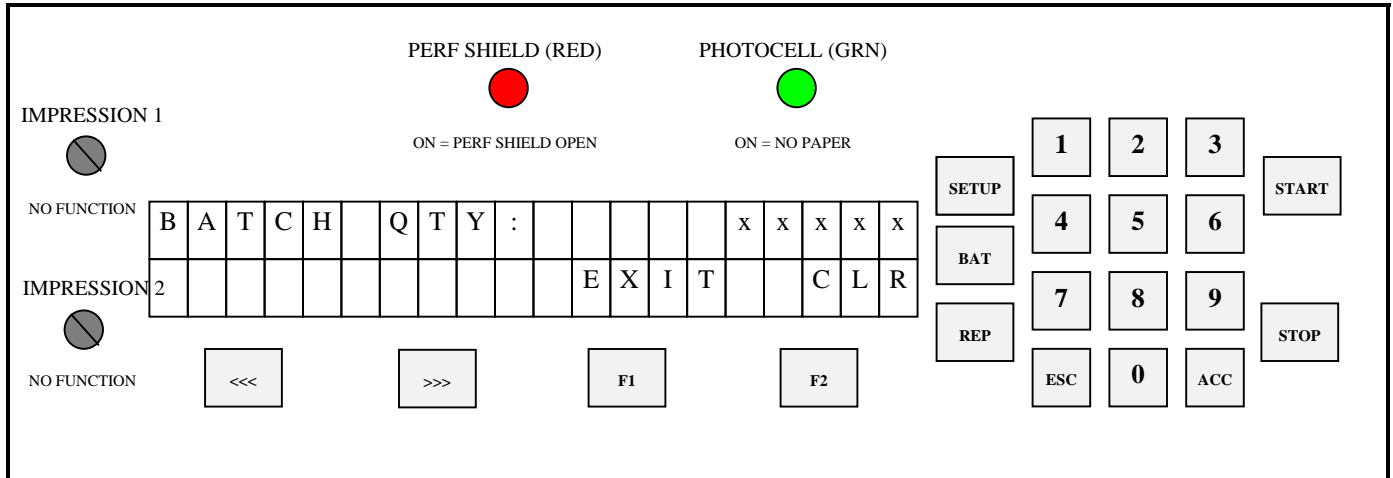

**DISPLAY FUNCTIONS:**

DISPLAY	
xxxxx = batch quantity	
EXIT = exit to <b>Mode - Idle</b>	
CLR = clear batch quantity	

This screen will show you how many batches you have completed. Multiply the 'BATCH QTY' by the 'BATCH SIZE', and you have the total quantity of your run. When the machine stops after each batch has been completed, you may insert a slip sheet in the *exit tray* and simply press the 'START' button to continue with the next set.

**3.6 The Repeat Function**

The repeat function key (REP) is a future feature for the GW 12000. Currently the *repeat selector* on the *numbering head* is used to obtain a repeat ability (as discussed in *Section 2.2*).

**3.7 Motor Speed Control**

The motor speed can be changed while the machine is running or idle. This function is performed by using the first two function keys under the *LCD display* screen (marked << and >>) when you are in the *main operating menu*.

The bottom line of the *LCD display* shows a down arrow to slow down the motor and an up arrow to speed it up. Maximum throughput speed is 8 000 sheets per hour (11 x 82" or A4), with one number per page.

## 4.0 Setting Up a Job

To set up the machine for a specific job, a few items must be adjusted depending on the specific stock being run, the number of heads being used and the number of perforations, slits or scores required. In order to keep it simple, adjustments required will be discussed from the feed end of the machine to the exit.

### 4.1 Aligning the Feed Tray Guides

As previously mentioned, the *operator side tray guide* should be seated all the way to the operator side. This will ensure that the stock passes directly underneath the *photocell*, allowing the program being run to initiate. With a pile of the stock placed in the tray, align the *non-operator side tray guide* with the pile. Allow a fraction of an inch so that the pile flows freely down the tray if released from the top.

Move the *centre slot cover* so that it is in the middle of the two *side tray guides* and tighten the wing nuts.

It is very important that the stock enters, the machine square, to ensure that all perfs are square and straight. To test for square feeding, place a piece of stock in the *feed tray* and align the lead edge with a straight edge within the machine (such as the straight edge of the *feed platen*, or the edge of the first shaft in the machine). Now, check that the *operator side feed tray guide* is parallel to the close edge of the paper for squareness.

### 4.2 Setting Feed Tire Pressure

The friction feed system used in automatic Graphic Whizard machines is unique. It utilizes three top *feed tires* to feed sheets through with a consistent pull along the full lead edge of the sheet, and a continuous width *sheet retarder* (the strip of fine sandpaper on the *feed platen*) to separate sheets and prevent double feeding.

Once the *feed tray* and *side tray guides* have been assembled according to the sheet width required, you may locate the *feed tires* along the *feed shaft*. For proper sheet feeding, the position of the three *feed tires* along the width of the sheet is also important. Loosen the set screws of the *feed tire hubs* using the small hexdriver provided in the accessory kit. Slide the *feed tire hubs* along the *feed shaft*, setting the two outer tires at about 12" in from the outside edges of the stock. The third, middle *feed tire* is simply centred. Keep the three setscrews of the *feed tire hubs* in line on the *feed shaft*. Tighten all setscrews. (see GW 8000 Layout on Page 2)

If a *feed tire* is set too close to the edge of the sheet, its feeding efficiency will be affected by variances in the stock such as sheet curl and inconsistent glue thickness on multiple padded forms. Improper setting of the *feed tires* can cause random skewing problems.

**Warning:**All *feed* and *exit tires*, and *perf/score/slit boss wheels* use setscrews to secure their positions. When tightening setscrews, do not over-tighten them. This may scar the metal shafts and inhibit the free sliding movement of the *feed tire hubs* or *perf/score/slit boss wheels*.

To ensure consistent, trouble-free feeding, the *feed tire* pressures must be set as loose as possible. **The *feed tires* should never contact the *retarder strip*!** Our design allows for no double feeding with substantially reduced feed pressure than the typical friction feed system. The gap between the *feed tires* and the *feed platen* should be just less than

the thickness of the stock being used. Remember that we are retarding the full lead edge of the next sheet or set. When setting the *feed tire* pressures, you should have the sense that the *feed tires* are just touching the paper. It is better to set the *feed tire* pressure to the minimum pressure required to

prevent double feeding. The remedy to correct double feeding is to turn down the both *feed tire pressure adjusting screws* a  $\frac{1}{4}$ th turn until consistent feeding is achieved. If the *feed tire* pressure is too much, you will possibly mark or pull apart forms.

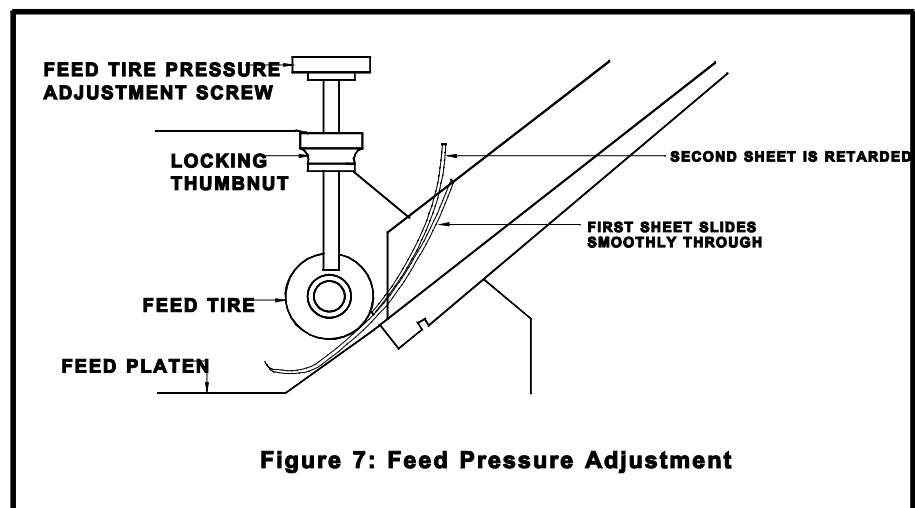

Adjustments for *feed tire* pressure are made with the *feed tire pressure adjusting screws* (see [Figure 7](#)). It is recommended to place two sheets of the stock in the *feed tray* with the *feed tire* pressure set loosely. Hold the two sheets in your hand with one sheet ahead of the other. Place the leading edge of the first sheet under the feed tires. Slowly tighten the *feed tire pressure adjusting screws* while jiggling the pages back and forth. The correct setting is achieved when the second page is no longer able to run under the *feed tires*.

All three *feed tires* should be adjusted to the same pressure setting to minimize skewing. To check that all the *feed tires* are adjusted to the same pressure, tear a strip off the stock being run and pass it under each *feed tire*

separately. You should sense the same amount of drag under each *feed tire*. A tighter *feed tire* pressure on one side of the sheet, will cause faster feeding of that side of the sheet (the sheet will skew or twist towards the *feed tire* with tighter pressure). To prevent this skewing, reduce pressure on the side of the *feed tire shaft* where you encounter more drag with a counter-clockwise,  $\chi$ th of the *feed tire pressure adjusting screw* and increase pressure on the other side by a clockwise,  $\chi$ th of that *feed tire pressure adjusting screw*. These adjustments should cause a change in the overall balance of pressure from the three *feed tires* without affecting the total *feed tire* pressure.

When you have the *feed tire* pressure set properly, you can then tighten down the white nylon thumbnuts to ensure the setting will be maintained.

**Note:** The only time the feed is too loose is if double feeding occurs (which the machine will detect and the message "PAPER TOO LONG" will appear on the LCD display). If the feed is too tight, the *feed tires* will try to pull only the top sheet off a set. If this occurs, loosen the *feed tire* pressure a little on both *feed tire pressure adjusting screws* evenly until this no longer happens.

With the GW 8000, carbonless sets feed best from a non-glued edge! Glue thickens the set and can cause waves on the edge, while the unglued edges tend to be more consistently flat.

**Advisory:** It may require several attempts to get used to this sheet-feed technique, and it is recommended that you practice a few numbering jobs with scrap paper. However, some initial trial and error experimentation will allow you to develop long-term benefits in efficiency.

#### 4.4 Perforating/Slitting

Perforating, slitting and/or scoring can be performed with or without any numbering. As previously mentioned, if no numbering is desired, program '00' has been set aside for this task. The perforator blades are available with 2, 4, 6, 8 and 12 teeth per inch as well as Microperf. The blades can be easily interchanged using the

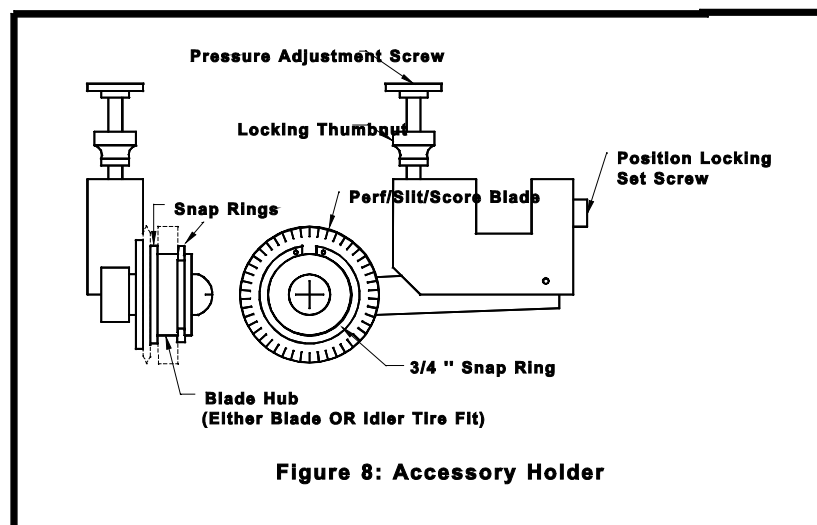

ring pliers supplied with the machine.

Remove the *accessory holder* (see [Figure 8](#)) from the machine. Simply remove the *retaining clip* from the *blade hub* and pop off the blade. Place the new blade on the *blade hub* and put the *retaining clip* back on. Ensure that the *retaining clip* sits completely in the groove in the *blade hub* in order to prevent any movement of the blade.

Using the small hexdriver, move the bottom *boss wheel* to the approximate location of the desired perforation or slit. (Note: Keep all of the setscrews of the boss wheels in line on the shaft.) Move the *accessory holder* to the position desired

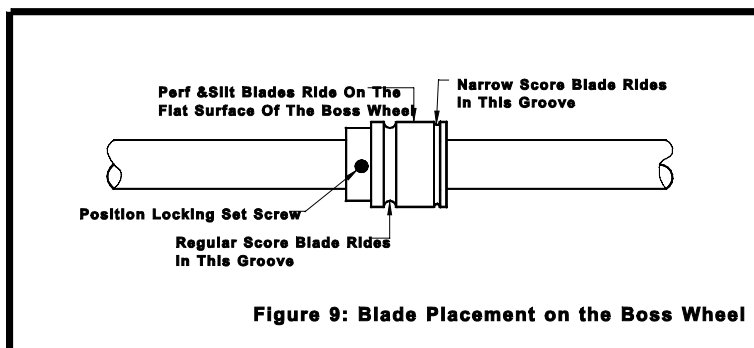

where the perf/slit blade will ride on the flat surface of the *boss wheel* (see [Figure 9](#)) and tighten the *position locking set screw* into the keyway of the square shaft (using the large hexdriver). Since you can control the depth of a perf/slit, it is critical that you locate your perf/slit wheel to the flat of the *boss wheel*. Tighten the *pressure adjustment screw* located on the top of the *accessory holder* and turn the *handwheel* at the same time. When the perf/slit blade turns with the *handwheel*, test a few sheets. Continue to make adjustments until the desired perforation depth is obtained.

To ensure a straight perforation, score or slit, run a few sheets through the machine. Using a straight edge, check if the perforation line is straight. If not, you may not have the *main tires* placed evenly across the sheet with one tire on the non-operator side. Next, flip the first inch of the lead edge of the sheet over and check to see if the perforation lines up. If it doesn't, double check that there is no excess play in the *tray side guides* and that the *operator side tray guide* of the *feed tray* is over to the operator side as much as possible. You may not be feeding the sheet into the machine square. To ensure that the sheet is running through the machine square, you can feed a sheet into the machine using the *handwheel* and align the lead edge of the sheet with a straight edge in the machine (such as the edge of the *bottom boss shaft*). To adjust the squareness of feed, you can move the front or back of the *operator side tray guide* on the *feed tray* to make sure the sheet travels through the machine square. If you adjust the *operator side tray guide*, you must adjust the *non-operator side tray guide* as well. Run a few more sheets through and check the sheet again. Continue until the perforation lines up. Now, take the lead edge of the sheet and fold it over to the last inch of the sheet. Again, you are checking to see that the perforation lines up. If it does not line up, again check that the perforation itself is straight. If not, check the *main rollers* for equal distribution over the sheet and also check that the *feed tires* have equal pressure

along the sheet. The *feed pressure adjustment screws* dictate the paper travel. The general rule to remember is that a perforation runs away from a tighter tire. If the perforation runs towards the non-operator side, then loosen the operator screw by an  $\chi$ th of a turn and tighten the non-operator side by an  $\chi$ th of a turn. Vice versa for a perforation that skews towards the operator side. Make adjustment to the *exit rollers* in the same way you make adjustments to the *main rollers* if the perf starts straight and then tails off. If the perforation is straight but the perforation does not line up, you may still not be feeding the sheet through square.

Whether perforating or slitting, place one of the *strippers* close to the cut. The new cut in the sheet can often cause the sheet to curl up and can cause a jam otherwise.

#### **4.4 Scoring**

Setting up a score is similar to perforating or slitting although the scoring blade will run in the groove of the bottom *boss wheel*. With a score, it is more critical to control the depth of the blade, because this controls the depth of your score. When lining up the blade and groove of the *boss wheel*, do not tighten the *boss wheel* until you have run the score blade into the groove using the *handwheel*. Once you have the blade and *boss wheel* lined up you can adjust the depth of the score and run some test sheets, adjusting the depth of the score until you are satisfied. Making adjustments for a straight score are done in the same manner as a perf/slit (as discussed in *Section 4.3*).

#### **4.5 Idler Wheel Holders**

On the same-keyed shaft that the *accessory holders* are mounted on, for your perf/score/slit operation, there are two *idler wheel holders*. These holders, if possible should be mounted about 1 to 12" from the outside edges of the stock being run. As the stock leaves the *feed tires*, it will then be perfed/scored or slit. The *idler wheel holders'* purpose is to equalize the force along the stock as it passes through this section, so you do not encounter any skew, which you may encounter if you only had a perf/score/slit wheel contacting the paper before going through the *main rollers*.

#### **4.6 Main Rollers**

The *main rollers* are comprised of a bottom solid roller and 6 adjustable rollers on top. The top rollers are mounted on a spring loaded shaft, to maintain pressure down to the bottom solid roller. The adjustable top rollers must be distributed along the shaft so that there is a roller on each end of the shaft, with the remainder distributed along the shaft. To ensure proper transport, a majority of the rollers should be on the stock, but do not load all rollers to one end of the shaft where you may encounter stock skew.

## 4.7 Installing Ink Pads

Loosen the large, star-shaped, lower knob on the *drive-unit mount block* and swivel the *drive unit* up. This will allow you better access to the *numbering head* itself. Slide the *repeat selector*, on the *numbering head*, over to the "0" position (see *Figure 4* if you are unfamiliar with the components of the numbering head). Pull down the *numbering wheel frame*, the *ink pad mount plate* swings away giving you better access to the *ink pad* and exposes the numbering wheels. Now press in the *locking tab* which sticks out from the top of the *head frame*. When you pull the *numbering wheel frame* down far enough, the *locking tab* will drop into a groove on the *numbering head shaft* and hold the head in this position. If you pull the *numbering wheel frame* too far down, the *repeat selector* may jam the head. Simply pull the *numbering wheel frame* further down and press the *repeat selector* out of the way.

Remove an *inkpad* from its package (provided in the accessory kit) and grasp the two plastic fingers on the back of the *ink pad holder*. Before inserting the *inkpad*, you must first condition the pad. Because the pad is felt, it may have swollen with ink and be thicker than need be. If inserted on the *numbering head*, an *inkpad* with a swollen felt can cause the *number wheels* to get too much ink and create splattering or fat images. To condition the *inkpad*, use a piece of coated stock (because it is less absorbent) and place the *inkpad* on the coated stock, felt side down. Press down hard on the *inkpad* to compress the felt. You can then soak up the excess ink with the pad. Once the pad is conditioned, you gently squeeze the plastic fingers inwards on the back of the *ink pad holder* and slide it into the groove on the *ink pad holder plate*, with the ink-reservoir side of the pad sliding in first. Release the tabs and the holder.

## 4.8 Locating the Numbering Heads

To move the *drive unit* into the lateral position required, loosen the large star-shaped knob near the bottom of the *drive unit mount block* (refer to *Figure 3*). Loosen the setscrew in the *anti-pitch block* using the large hexdriver. This will allow you to slide the *drive unit* across the width of the machine. You may now move the *drive unit* to the location desired. Bring the *anti-pitch block* over to and against the *drive unit*. Now tighten the large star-shaped knob and set screw in the *anti-pitch block* to lock the *drive unit* in place.

The *anti-pitch block* and *drive unit mount block* act together when locating a number position. If the number position is slightly off, you can loosen one of the blocks and move it over the appropriate distance, using the fastened block as a reference point. Also, when going to replace the *inkpad*, you may move the *drive unit* aside, leaving the *anti-pitch block* in position as a reference when you wish to continue the job.

To turn the *numbering head* so that it prints the number in the correct rotation, first loosen the *rotation lock screw* on the *numbering head mount block*, just above the *numbering head*. The *numbering head* will then be free to rotate to the desired orientation.

When satisfied, be sure that the head has been returned to the print position and all knobs have been tightened.

Once you have the *numbering head* in the correct physical position, program the job. It is advised that you run a few test sheets to check the strength and quality of the crash impression.

#### **4.9 Setting Impression Control**

After setting up the machine and then programming a job (*Section 3.4*), test sheets will have to be run to verify you are getting the correct impression, in other words: number sequence; crash strength; level impression; etc.

The *Impression Control Dials*, located on the *control panel* regulate the strength of the crash. Simply turn the dial clockwise if more impression is required for multi-part carbonless work. Check the bottom carbonless copies of the form to see if the impression strength is adequate. If the maximum setting is not adequate, contact your dealer.

**Reminder: Carbonless impressions are created as a development process similar to developing a photograph. The numbering image will continue to darken for a full twenty-four hours but will reach about 80% of its full colour in about twenty minutes. Ink chemistry, offset powder and a number of other factors can affect both the time and the extent of the image. Your fresh impressions will be lighter than you want but trust them to darken. What you want to achieve is an even, level impression with minimal or no embossing of the stock.**

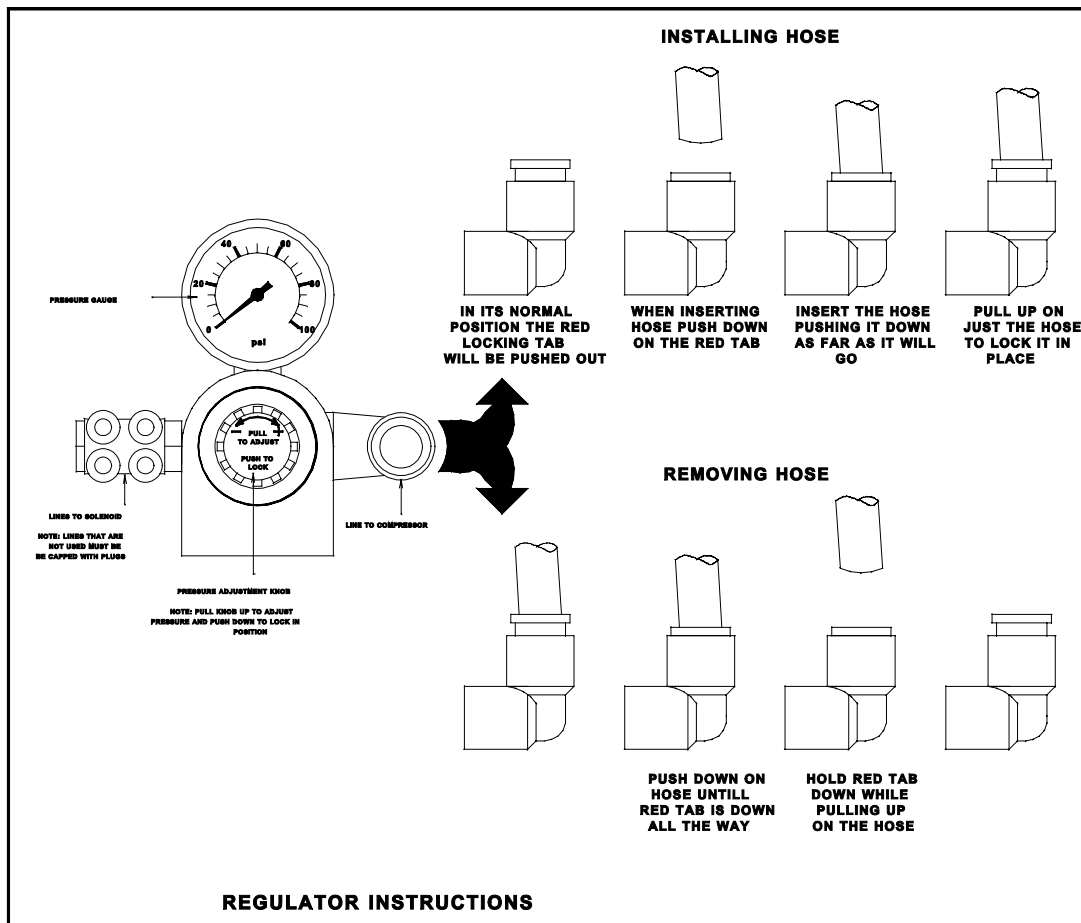

With the GW 8000, the *numbering heads* are pneumatically driven. The air pressure is regulated from the air source (whether shop air or a stand-alone compressor) on the machine at the *regulator/gauge/manifold assembly*. The optimum pressure setting at the *regulator* is 45-60 psi. If numbering a job with many numbers, you may need to increase the *Impression Control* to maintain a consistent impression or increase the air pressure at the *regulator* by 5 psi.

#### 4.10 Flatness of Impression

It is best to check for the flatness of the impression on the bottom crash copy from a carbonless set. The inked impression will not adequately show whether the impression is truly flat while the bottom crash impression shows this quite well. Make some test impressions on carbonless, verify the flatness of the crash impression and follow the proceeding instructions.

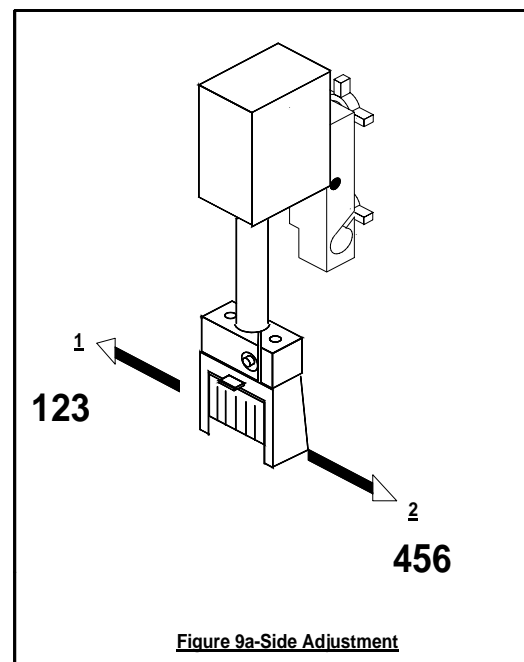
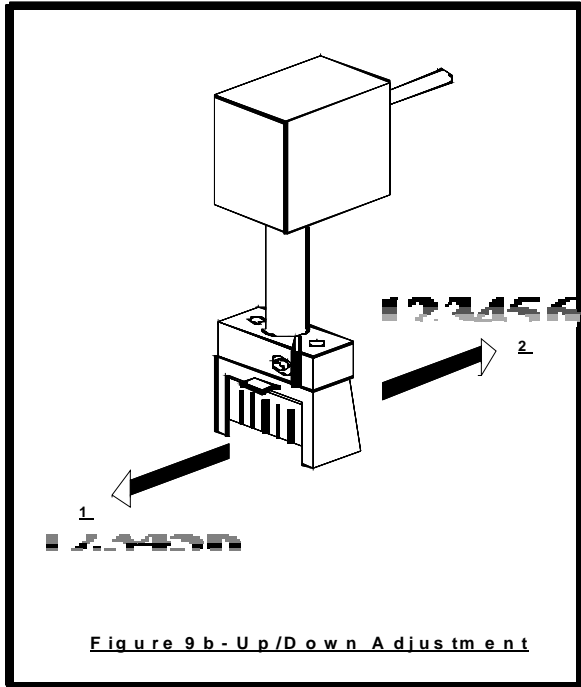

Figure 9a-Side Adjustment

To adjust for an uneven side to side impression (ie. if the impression is too light or too heavy across the machine), determine in which direction the *numbering head* must pivot to flatten the crash (consult *Figure 9a*, which is viewed from the non-operator side of the machine). For adjustment '1' to pitch the *numbering head* away from the non-operator side, loosen the top *hand knob* on the *drive unit mount block* and turn the *left/right pitch screw* counter clockwise. Similarly, turn the *left/right pitch screw* clockwise for adjustment '2'. To adjust for an uneven top to bottom impression, determine in which direction the *numbering head* must pivot to



flatten the crash (consult *Figure 9b*).

Adjustments for forward/backward pitch are made by first loosening the bottom *hand knob* on the *drive unit mount block* and turning the *forward/back pitch screw* in the appropriate direction. After adjusting, number another carbonless set and make necessary adjustments until the *numbering head* creates an equal impression along the whole number.

#### 4.11 Stripper Assemblies

Each machine is supplied with a minimum of 3 *stripper assemblies*. Their purpose is to keep the stock flat as it runs through the machine and to ensure that the stock does not catch on the *numbering head*. The *stripper blocks* are to be mounted on the keyed square shaft, pointing down, the same shaft that the *accessory holders* are mounted on. They should normally be located close to the numbering head but not underneath the *numbering wheels* (this can damage the *numbering wheels*!) or close to where a perf/score/slit is being performed..

If you experience double images when numbering, it is possible that the *stripper* pressure is not enough to keep the stock flat for the crash and the stock is bouncing , allowing a second image to occur. If this occurs, simply bend the *stippers* down to create more pressure on the paper.

## 5.0 RUNNING A JOB

### 5.1 Setting the Starting Number

In order to set the starting number on the *numbering head*, you will have to pivot the *drive unit* back to get clear access to the *numbering wheels*. Pull down the *numbering wheel frame* and push in the *locking tab* to engage and lock the *numbering head* with the *numbering wheels* exposed.

Each individual *numbering wheel* can be rotated to the appropriate starting number using the *change stick* provided in the accessory kit. Remember that the standard head counts backwards so the number that you set to start the job on will be the last number required.

If you do not require all the digits to print (ie. 0097 is desired instead of 000097), the last two *numbering wheels* can be dropped from profile and locked down. To do this, rotate the *numbering wheel* to the "9" position. Turn the wheel slightly past this position while also pushing down on the "9". When the correct position is reached, the "9" will drop below type height. To restore a dropped wheel to its regular print position, simply rotate the wheel in the regular direction and it will "pop" out of its sunken position and back into regular print position.

Once your number has been set, and the inkpad has been installed (see *Section 4.7*), set the *repeat selector* to "0". Now, pull the *numbering wheel frame* downward to release the *locking tab*. Gently release the *numbering wheel frame* and allow it to return to its rest position. [**Caution:** the *numbering wheel frame* is spring loaded. Once you release the *locking tab*, the *numbering wheel frame* will spring back quickly. Please make sure that you keep your fingers clear of the inner workings of the *numbering head*] If you pull the *numbering wheel frame* down too far and it locks, refer to *Section 4.4*. If you do not return the *numbering wheel frame* to its rest position, the *numbering head* will not operate when the machine is running, since it is already at the end of its available stroke-length. Now you can pivot the *drive unit* back to the print position and re-tighten the large knob.

It is advised to set the *repeat selector* to '0' while running a few test sheets so that the starting number does not change. When you are ready to start your numbering job, then change the *repeat selector* to the action desired.

## 5.2 Setting the Repeat Selector

The *numbering heads* can be set to repeat a number continuously ("0"), change with every crash ("1"), or change after a number of crashes (ie. "2, 3, or 4"). This setting will depend on the type of job required. The *repeat selectors* is clearly in view on the front of the *numbering head* and requires no special tools to be changed (see *Figure 4*). Remember, for 2x, 3x and 4x repeat action, you may need to run a couple of test sheets to ensure these actions match your numbering sequence, since the *numbering head* is a mechanical process separate from the number position programming.

If the repeat sequence does not match the numbering sequence on your stock, you may need to manually engage the *numbering head*. Push down on the *numbering wheel frame* as many times as it takes to complete the repeat action, counting where the sequence was on your last test sheet.

**Example:** Repeat action desired is a three time action. After running a test sheet, '9 9 8' is printed. The *numbering head* is in mid-sequence and to correct, push down on the *numbering wheel frame* twice to complete the repeat action. Test another sheet and the sequence printed now is '7 7 7'.

## 5.3 Fanning

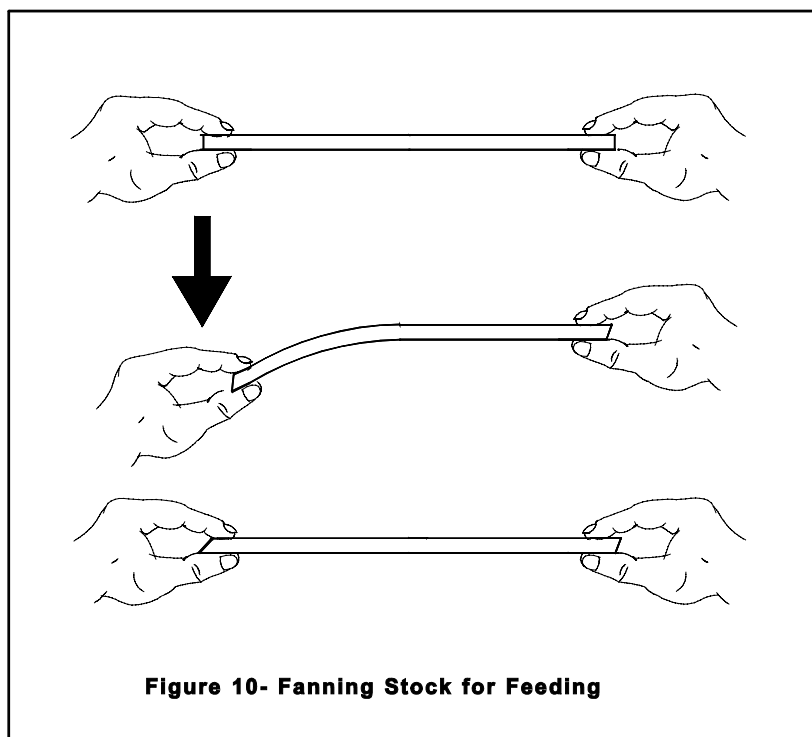

The final feeding concern is the fanning of the stock. This procedure may also take some practice, and in particular when fanning carbonless sets across the un-glued edge. The following steps should be used in order to fan the pile:

- 1) hold the paper as shown in *Figure 10*;
- 2) lower your left hand while holding on to the pile firmly with your right;
- 3) hold the pile tight with your left hand and loosely with the right;
- 4) return the left hand to its original position

5) repeat steps 1 through 4 until adequate fanning is obtained.

Try fanning while holding the stack in a vertical, upright position, with the glued edge resting on a table. This will maintain a flat, straight edge.

When loading a fanned stack into the *feed tires*, hold the back end of the stack up high (at approximately a 30-degree angle, relative to the *feed tray*) so that the lead edge slips under the *feed tires* (see *Figure 11*). Then, gently lower the stack onto the *feed tray*. Before starting the machine, rotate the *handwheel* one half turn and watch that the first sheet of the stack advances correctly, while the second sheet beneath it should be retarded from feeding into the machine.

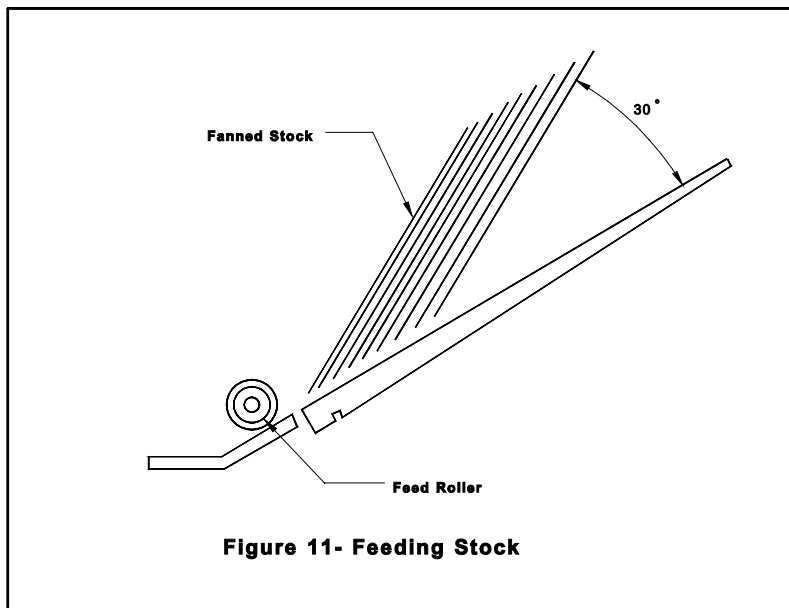

The efficiency of the feeding can be improved by increasing the spacing between the sheets of your fanned stack. Begin with small stacks (10 to 20 sheets) and build up to larger stacks as you become more confident with your fanning.

Once you have mastered the art of fanning, you can progress to back feeding to provide

continuous feeding and uninterrupted operation. To feed while the unit is operating, fan a stack and, while holding it in your right hand, carefully grasp the bottom set of the feeding stack with your left hand. Raise the back edge of this bottom set, thus slightly raising the back of the feeding stack, and slide the new stack under it. Release the new stack into the *feed tray*, letting it slide down under the feeding stack. Lower and release the back edge of the bottom set so that the stacks now sit together. This back-feeding procedure should be done while there is still sufficient stock in the *feed tray* to allow for the time needed to prepare and insert the new stack.

## 6.0 Maintenance

The GW 8000 is designed to be trouble-free through years of use. Only minor maintenance operations are required to keep it running like new.

### 6.1 Numbering Heads

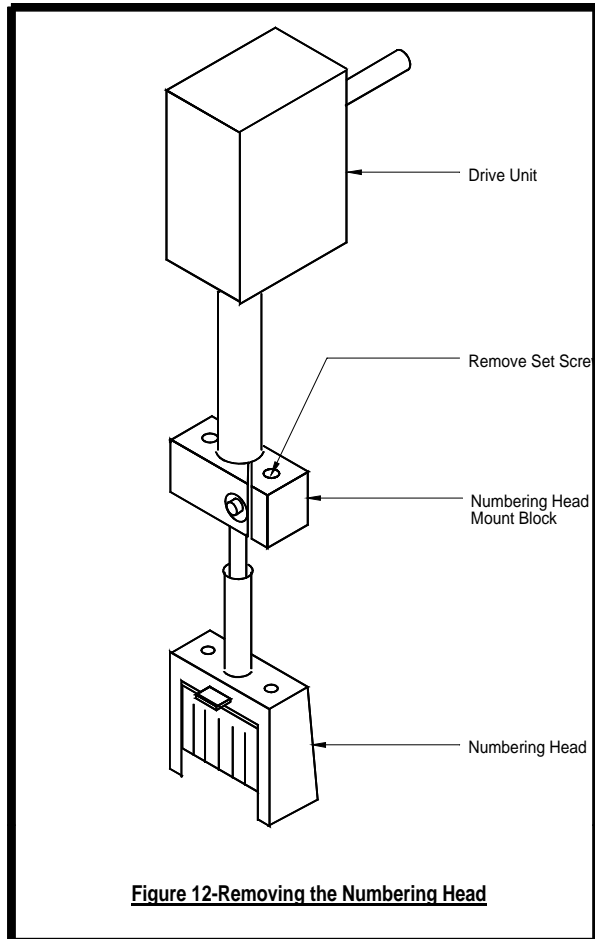

With use, the *numbering heads* will acquire a coat of old ink, paper dust, etc. and therefore periodic cleaning is necessary. The minimum frequency of *numbering head* cleaning is once a month or when changing over colors. Detach the *numbering head* by removing the two setscrews on the *numbering head mount block*, using the larger hexdriver provided (see *Figure 12*). The head may then be cleaned with a petroleum based spray lubricant (such as WD-40 or Sprayaway RD-90) and a small brush (ie. an old toothbrush). Spray and soak the *number wheels* thoroughly. Take care to keep the spray away from the rest of the machine. Brush the wheels and then rotate them in order to clean every digit. Spray the *numbering wheels* a final time to rinse out the ink or dust. After cleaning, allow the head to dry completely (ie. leave it standing overnight) or blow it dry with

compressed air. Wipe the head and reinstall.

**Important: Do not use solvents. Solvents will strip out the lubricants from the head, allow corrosion and impair the correct functioning of the print head.**

### 6.2 Machine Cleaning

After each job, or midway through a very large job, clean the *feed tires*. You can use warm water to clean off paper dust or drying powder, or blanket wash or alcohol if there is ink on the *feed tires*. Any type of rubber roller rejuvenator is also good to clean the *feed tires*, the rejuvenator will also soften the rubber. This will prevent glazing of the rubber. Brand new tires will require extra cleaning for the first job or two until the rubber beds in.

In addition, always watch that paper dust or dirt does not block the two-photocell sensor eyes. The “green” light on the control panel marked “PHOTOCELL” can verify correct photocell operation. If dirty, simply wipe the photocell sensor eyes but **do not use solvents**. Either use a cotton swab or blow clean with compressed air.

Ensure that the trays and guides are clean.

### **6.3 Lubrication**

The Model HS utilizes ten oil-impregnated bronze bushings to support all shafts. An occasional drop of light machine oil will maintain their lubricating qualities. Wipe off any excess oil to avoid spoiling a job.

### **6.4 Friction Feed**

Over time, the rubber components of the *feed tires* may wear or harden. Use a rubber roller rejuvenator occasionally to soften the rubber. Other than the *feed tires*, another important element of the friction feed system is the full lead edge *retarding strip*. The abrasive agent on the *retarding strip* prevents sheets from double feeding. As the abrasive agent wears, you will encounter more double feeds and when you see the green backing of the *retarding strip* you must replace it. To replace the *retarding strip* for the feed, adjust the *feed shaft* to its highest position. Using a scribe or sharp edge, etch into the *feed platen* where the *retarding strip* ends (you will use this scribed mark as a reference point when you apply the new *retarding strip*). Peel off the old *retarding strip* (you may need a knife or razor) and remove any old adhesive with alcohol. Replace with a new self-adhesive *retarding strip*. Make sure that there is some of the *retarding strip* surface under the *feed tires* to ensure proper operation.

## **7.0 TROUBLESHOOTING**

### **SYMPTOM**

### **SOLUTION**

#### **Friction Feeder**

Double-Feeding

Adjust *feed tires* down by an  $\chi$  turn (feed is too loose); if the *retarding strip* is glazed or worn (you can see the green backing), replace *retarding strip* (see Section 6.4)

Creasing, marking,  
or sets pulled apart

Adjust feed tires up by an  $\chi$  turn (feed is too tight)

Kicking, turning

Balance adjustment on *feed shaft* required (one side is too tight); adjust feed tray guides closer together to eliminate side to side play (see Section 4.1 & 4.2 for adjustment instructions).

Not feeding paper

Feed may be too loose in which case, multiple sheets are jammed under the *feed tires*, check adjustment; if *feed tires* are smooth or glazed, clean, rejuvenate or replace; open *feed tray guides* (set too tight to paper width and pinching stock)

#### **Print Quality**

Uneven crash  
impression

Adjust for crash flatness (see Section 4.11)

Faint colour or uneven  
colour impression

Replace ink pad. (see Section 4.7)

Excessive inking

Clean head (see Section 6.1); condition ink pad (see Section 4.7) or replace leaking ink pad.

Too heavy (embossing)  
or too light a crash

Adjust *Impression Control* dial. (see Section 4.10); check *platen pad*, if there is excessive wear, the *platen pad* may require replacing.

Ink spreading, smudging  
or not drying

Numbering machine ink is mineral oil with pigment. The oil is absorbed by the paper leaving the pigment behind as the image. On slick or glossy stocks, the supplied inkpad will not work effectively. A non-corrosive ink must be used as a substitute (such as fountain pen ink). An important factor with alternative inks is that the

*numbering heads* be cleaned immediately after a job has been run.

## Registration

Inconsistent number location (poor number register)

Check that the photocell is clear of any obstacles (*see Section 6.2*); if the number location seems to 'float', the *feed tray guides* may be too loose allowing sheets to skew as they feed (this will be seen more often with number locations closer to the non-operator side, furthest away from where the sheet passes the photocell; if numbers occur all over the place, the photocell may require readjustment (it is too sensitive, mis-registering the lead edge of the sheet)

Perf/score/slit line skewing

With a straight edge, check that the perf/score/slit is straight. If straight, the stock is not feeding square, the *feed tray guides* may need adjusting to ensure the stock enters square into the machine. If the perf/score/slit line is not straight but is bowed or has a tail whip, the rollers on the *main shaft* and/or the *exit shaft* may not be evenly balanced along the shaft, causing uneven pressure on one side of the stock. This causes a skew and the rollers must be evenly spaced across the shaft. A bowed line usually indicates the rollers on the *main shaft* are uneven, and a tail whip usually means the rollers on the *exit shaft* are uneven.

## Numbering Heads

The *numbering heads* creating an impression are a mechanical process separate from the programming of the machine. If encountering problems with the correct operation of the *numbering head*, such as *numbering wheels* not turning, numbers partially printing, *numbering wheels* turning out of sequence, etc. the *repeat selector* or other components may be out of alignment (refer to *Figure 4*). Being a mechanical process, alignment of the individual parts is very important. Remove the *numbering head* from the machine. Pressing down on the *numbering head shaft*, you will see the *numbering head frame* slide down the *print head frame*. While this happens, the *ink pad holder mount bracket* will swing away, exposing the *numbering wheels* (*see Figure D*).

The *numbering wheels* and *repeat action ratchet wheels* are mounted on a keyed shaft inside the *numbering head frame*. The wheels are then held in place, and refrained from spinning by the *retaining pawls*, which are forced to the *numbering wheel flats* by the *comb spring*. The *retaining pawls* must be aligned with the flats of the *numbering wheels*, or what looks like in between the *numbering wheels*. The *comb spring* must also apply a constant pressure against the *retaining pawls*. Consequently this alignment not in effect is that the *numbering wheels* may spin freely, causing partial impression or random numbering sequences.

Like the *retaining pawls*, the *changeover pawls* of the *repeat selector* must also be aligned to the flats of the *numbering wheels*. When an impression is made, the *numbering wheel frame* is propelled down the *print head frame*. The *ink pad holder mount bracket* swings away, the *repeat selector* is pushed back from the *numbering wheels* and the *numbering wheels* are then exposed to make their impression on the stock. After reaching the bottom of its stroke, the *numbering wheel frame* then returns to the top position. As this happens, the *repeat selector's changeover pawls* once again come into contact with the *numbering wheel flats*. Depending upon the action or sequence in place, the *repeat pawl* may only interact with one of the *repeat action ratchet wheels* before the *changeover pawls* interact with the *numbering wheel flats*. In most instances, the longest *changeover pawl* comes into contact with the flat of the unit wheel flat to change it over. After a "0" has been printed, there will be more *changeover pawls* changing more *numbering wheels*. When this happens, you may find the next impression, with a "9" as the last digit, printing lightly. This can be overcome by increasing the *Impression Control* to provide a stronger pulse to turn over more wheels. If you are encountering problems where numbers are not turning over, numbers are printed out of sequence, etc., then the problem may be that the *changeover pawls* of the *repeat selector* are not aligned with the flats of the *numbering wheels*.

The *repeat selector* is mounted on the *print head frame* by the two *repeat selector adjustment screws*. The *repeat selector* must be mounted to the *print head frame* squarely. If not, the *changeover pawls* will not engage the flats of the *numbering wheels* square, in this case some of the *changeover pawls* can not change their *numbering wheels*. Visually, check that the *changeover pawls* are riding in-between the *numbering wheels*, centred on their flats. If not, the whole *repeat selector* may be moved to the proper position by loosening the *repeat selector adjustment screws*. Lastly, the *changeover pawls* must be parallel to each other.

