

SquareFold

Model 104

Operator Manual

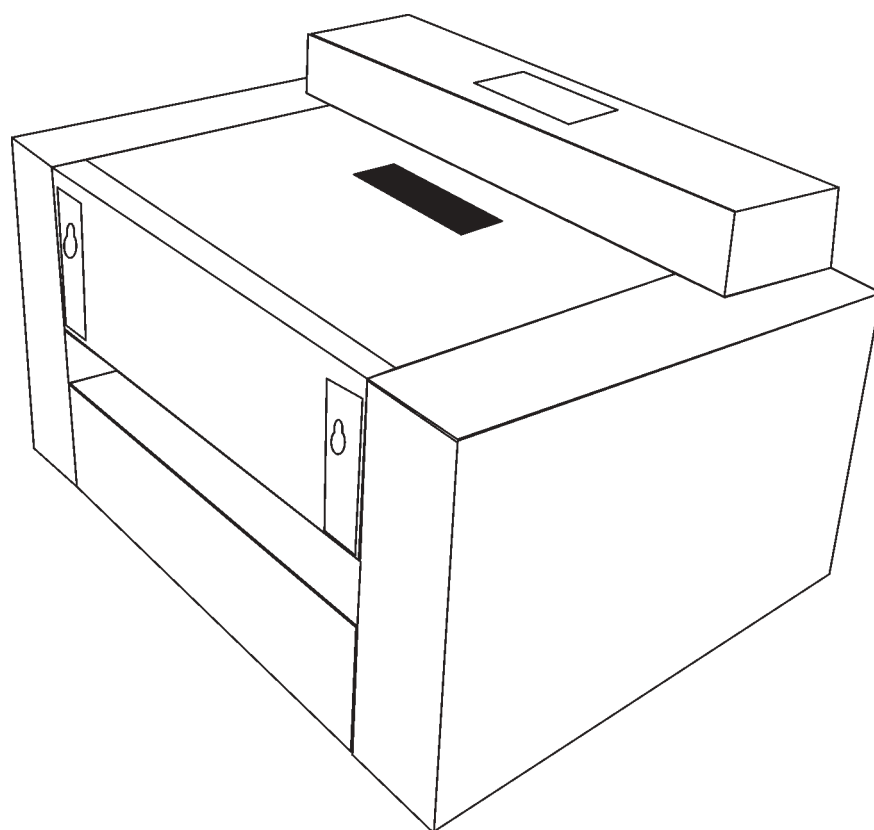

November 2002

Part no. 17308

Table of contents

1. Introduction

1.1	Operation safety	1-1
-----	------------------	-----

2. Getting to know the SquareFold Model 104

2.1	Main components	2-1
2.2	The control panel	2-3

3. Making Square folds

3.1	Making square folds	3-1
3.2	Bypass mode	3-1
3.3	Stacker full sensor	3-1
3.4	Operating the SquareFold	3-2

4. Maintenance

4.1	Cleaning the feed belts	4-1
-----	-------------------------	-----

5. Troubleshooting

4.1	Clearing jams	4-1
4.2	Troubleshooting	4-2

6. Specification

6.1	Specification	6-1
-----	---------------	-----

1. Introduction

1.1 Operational safety

Attention to the following notes ensures the continued safe operation of your equipment.

Always connect the equipment to a properly grounded power source receptacle. In doubt, have the receptacle checked by a qualified electrician.

WARNING: Improper connection of the equipment grounding conductor can result in electrical shock.

Always follow all warnings marked on, or supplied with, the equipment.

Always locate the equipment on a solid support surface with adequate strength for the weight of the machine.

Always exercise care in moving or relocating the equipment.

Always keep magnets and all devices with strong magnetic fields away from the machine.

Never use a ground adapter plug to connect the equipment to a power source receptacle that lacks a ground connection terminal.

Never attempt any maintenance function that is not specifically described in this documentation.

Never remove the covers or guards that are fastened with screws.

Never install the unit near a radiator or any other heat source.

Never override or “cheat” electrical or mechanical interlock devices.

Never operate the equipment if you notice unusual noises or odors. Disconnect the power cord from the power source receptacle and call your customer service engineer to correct the problem.

2. Getting to know the SquareFold

This chapter contains basic information about the SquareFold and its components.

2.1 Main Components

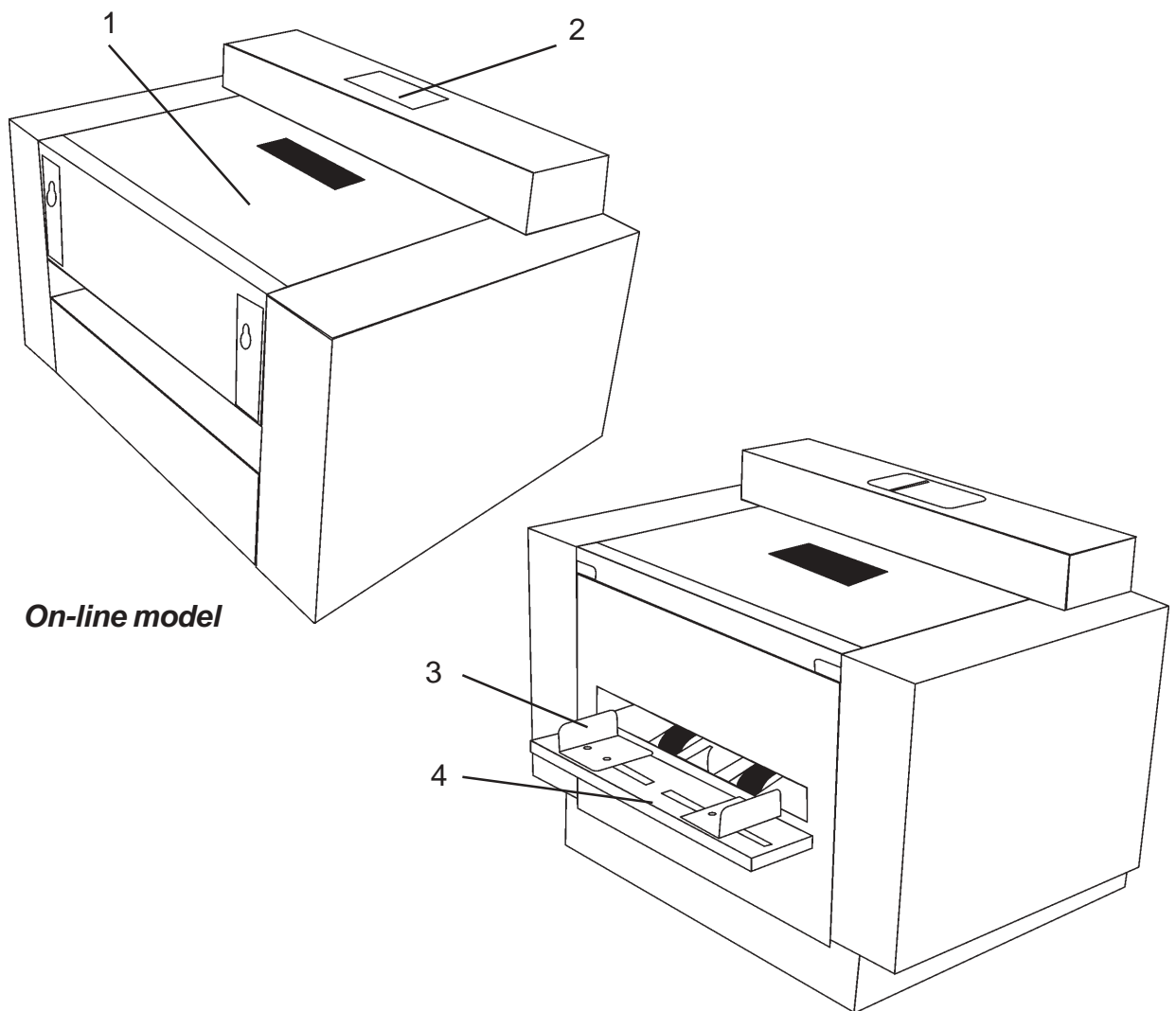

On-line model

Off-line model

1. Top cover
2. Control panel
3. Side Guides
4. Manual feed tray (Off-line Model)

2.1 Main Components cont.

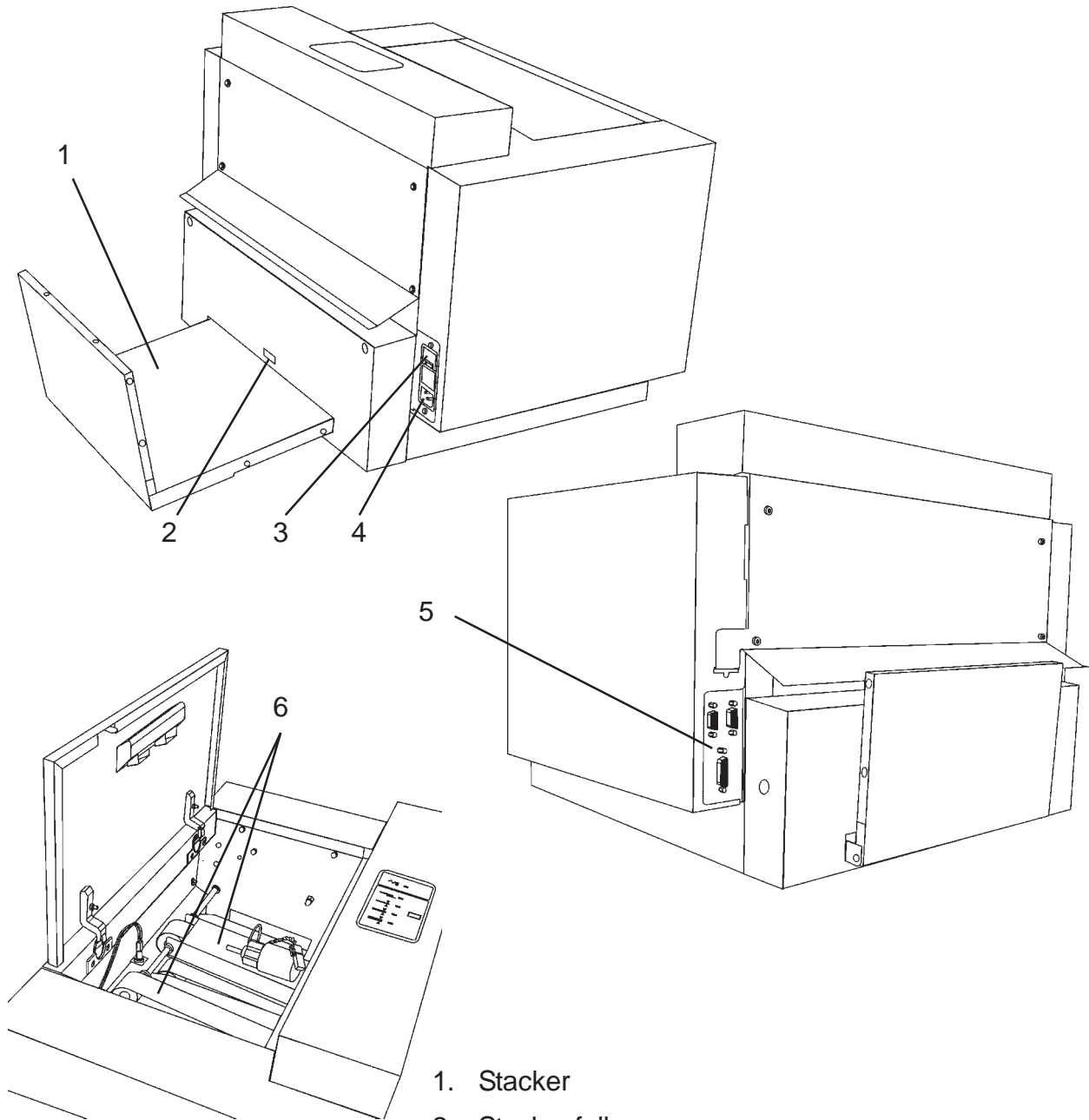

1. Stacker
2. Stacker full sensor
3. Main Power switch
4. Power receptacle
5. Communication connectors
6. Feed belts

2.2 Control Panel

The control panel of the SquareFold has one button to select the different modes. The control panel also has a number of indicators to display the operation mode and to display if a jam occurs.

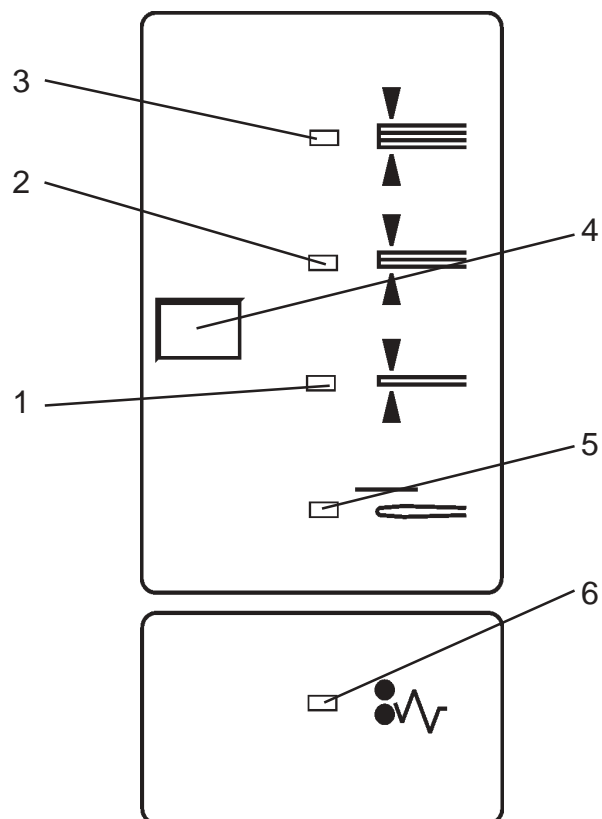

1. Mode 1: 6 to 10 sheets *
2. Mode 2: 11 to 15 sheets *
3. Mode 3: 16 sheets or more *
4. Mode select button
5. Bypass mode: 0 to 5 sheets
6. Jam indicator

Note:

* 80 gsm or 20 lb bond

3. Making square folds

Description

The SquareFold takes your normal booklets and makes them look more like perfect bound (glue bound) books. The output lays flat for easy packing and you are also able to print on the back (spine) of the book for easy retrieval in bookshelves. The SquareFold runs up to 1800 sets / hour depending on which mode that is selected.

3.1 Square fold booklets

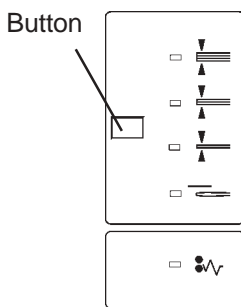

In order to produce optimum book quality the SquareFold unit operates in 3 different modes depending on the thickness of the book. Select mode by pressing the mode select button.

Mode selection guide lines

- Mode 1 for 6–10 sheets (80 gsm or 20 lb bond stock)
- Mode 2 for 11–15 sheets (80 gsm or 20 lb bond stock)
- Mode 3 for 16 or more (80 gsm or 20 lb bond stock)

3.2 Bypass mode

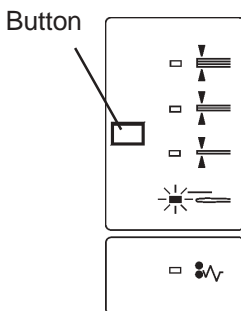

Forming the spine square is not advisable for booklets containing 5 sheets or less.

Select bypass mode when making booklets with less than 6 sheets, or when no forming of the spine is desired.

3.3 Stacker full Sensor

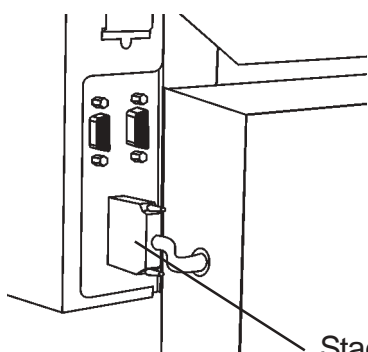

The SquareFold is equipped with a stacker full sensor. In mode 1 and 2, stacker full signal appears 30 booklets after the stacker full sensor has been blocked. In mode 3 and Bypass, stacker full signal appears 20 booklets after the stacker full sensor has been blocked. Whenever the books are removed the count starts from zero again. If the stacker full function is not desired, disconnect the stacker full plug from its receptacle.

3.4 Operating the SquareFold

1. Switch on the Main Power Switch.
2. Place a finished booklet on the stacker. Adjust the stacker by lifting up rear end and move it in/outwards to fit the booklet.
3. Select mode according to section 3.1/3.2. The SquareFold is now set up to receive booklets delivered from the Trimmer or fed by hand.

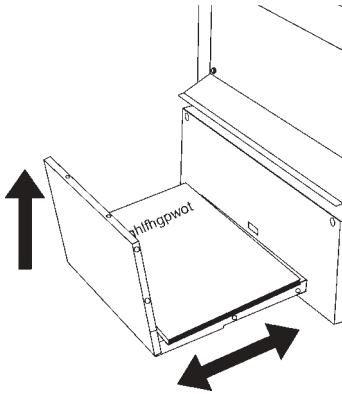

Hand feeding

4. Adjust the manual feed tray side guide to the width of the booklet.
5. Place the booklet on the manual feed tray and gently push it in (spine first). The feed belts energize automatically and pulls the booklet into the SquareFold. When the book exits the SquareFold, the next booklet can be fed into the SquareFold.

4. Maintenance

4.1 Cleaning the Feed Belts

Clean the feed belts using a mild soap detergent every 10 000 sets or earlier if needed.



5. Troubleshooting

5.1 Clearing Jam

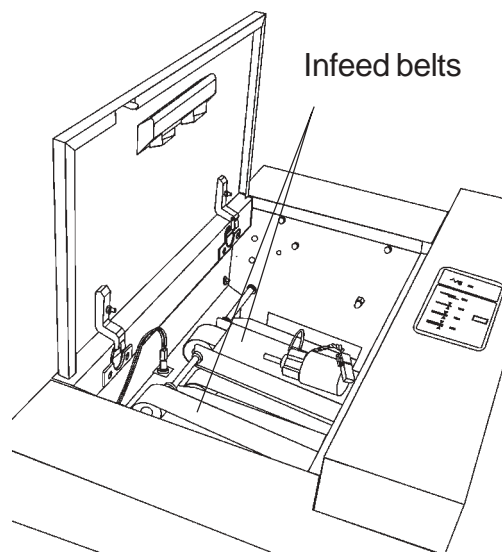
1. Open top cover, lift up both infeed belts and take out the jammed booklets.
2. Place feed belts in there normal position and close the top cover.

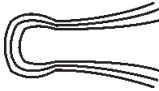

5.2 Troubleshooting

PROBLEM	POSSIBLE CAUSES	ACTION
The jam indication LED is flashing.	Jam inside SquareFold module. Stacker is full.	Open the top cover and take out the jammed set. See section 5.1. Clear the stacker from booklets.
There is print residue on the cover of the SquareFold booklets.	There is print residue on the belts.	Clean the feed belt according to section 4.1.
There is print residue on the spine.	There is print residue inside the SquareFold.	Run sets with white covers (not printed) until residue disappears.
	The booklet is not enough pressed.	Correct the mode. Change to higher mode 2 or 3.
	The booklet is pressed to much.	Correct the mode. Change to lower mode 2 or 1.
	When the booklet is pressed too much the fold can become corrugated. Especially on booklets containing few sheets.	Correct the mode. Change to mode 2, 1 or bypass.

6. Technical Specification

6.1 Technical Specification

Model 104 SquareFold	
Speed (mode 1, 2 and Bypass)	Max 1800 sph
Speed (mode 3)	Max 1300 sph
Capacity	Up to 24 sheets of 80gsm (96 page book) (20 lb bond)
Booklet size	Min Max
	100 x 120 mm (4" x 4 ¹ / ₂ ") 240 x 325 mm (9 ¹ / ₂ " x 12 ³ / ₄ ")
Jam detection	Yes
Stacker full detection	Yes
Dimension (HxWxD)	329 x 405 x 560 mm (13" x 16" x 22")
Weight	30 kg (66 lb)
Voltage	105/115/125/220/230/240V 50-60 Hz

Machine design and specification subject to change without notice

