

Serial Numbers 055188 & Up

# OPERATOR'S MANUAL



## ***HANDY-DRILL*** ***PAPER DRILLING MACHINE***

*Sold and Serviced by*

**The Challenge Machinery Company**  
6125 Norton Center Drive  
Norton Shores, MI. 49441

[www.challengemachinery.com](http://www.challengemachinery.com)

**F.101-O**  
June 2005

# 1.0 Introduction

---

THIS MANUAL is designed to help you get the most from your Challenge equipment. Keep this manual in a safe, convenient place for quick reference by operators and service personnel.

## **CAUTION**

**SAFETY ALERT!** This symbol means **CAUTION: Personal safety instructions!** Pay special attention to the instructions in bold type. Personal injury may result if the precautions are not read and followed.

**READ THIS MANUAL BEFORE OPERATING!** Follow precautions and instructions. If after reading the manual, questions remain, please contact your Authorized Challenge Dealer.

Take a few minutes right now to **RECORD YOUR MACHINE SERIAL NUMBER** in the space provided on the front cover of this manual. Also be sure to fill out the warranty card accompanying your machine and return it **DIRECTLY TO CHALLENGE**.

If you bought a used machine, it is important to have the following information on record at Challenge. Copy this page, fill in the information and send it care of The Challenge Service Department, 6125 Norton Center Drive, Norton Shores MI. 49441.

CHALLENGE MODEL Handy-Drill	SERIAL NUMBER	
ATTN	COMPANY	
ADDRESS		
CITY	STATE/PROVINCE	ZIP
PHONE	DATE INSTALLED	
DEALER NAME & CITY		

### \* WARRANTY INFORMATION \*

It is very important that you read and understand the conditions outlined in the *Warranty Information Sheet* attached to the outside of the shipping container of your machine.

The *Warranty Information Sheet* must be filled out completely and returned to THE CHALLENGE MACHINERY COMPANY in order for the warranty to be issued for this machine.

---

**TABLE OF CONTENTS**

1.0 Introduction .....	2
2.0 Safety .....	4
2.1 Precautions .....	4
2.2 Power Lockout Procedure .....	4
2.3 Warning Label Definitions .....	5
3.0 Packing List .....	7
4.0 Specifications .....	8
Minimum Distance Btw. Holes .....	8
5.0 Installation & Setup .....	9
5.1 Inspecting Shipment .....	9
5.2 Uncrating .....	9
5.3 Cleaning .....	9
5.4 Assemble Loose Items .....	9
5.5 Power Hook-Up .....	9
6.0 Operation .....	10
6.1 Set Hole Spacing .....	10
6.2 Set Drilling Depth .....	10
6.3 Drilling .....	11
6.4 Rotate the Drilling Block .....	11
6.5 Empty the Paper Chips .....	11
6.6 Drilling with 2 Inch Long Bits .....	11
7.0 Troubleshooting .....	12
8.0 Drilling Tips .....	13
9.0 Footprint .....	14
10.0 Safety Systems Test .....	16

## 2.0 Safety

---

### 2.1 Precautions

- This machine is designed for one-person operation. Never operate the machine with more than one person.
- Always wear safety glasses while operating this machine.
- Safe use of this machine is the responsibility of the operator. Use good judgment and common sense when working with and around this machine.
- Read and understand all instructions thoroughly before using the machine. If questions remain, contact the dealer from which you purchased this machine. Failure to understand the operating instructions may result in personal injury.
- Only trained and authorized people should operate this machine.
- **DO NOT ALTER SAFETY GUARDS OR DEVICES.** They are for your protection. Severe personal injury may result.
- **Disconnect power** before cleaning or performing maintenance. See Section 2.2 Power Lockout Procedure.
- Observe all caution labels on this machine.
- Be sure the drill is plugged into a properly grounded outlet.
- Be sure there is sufficient power to operate the drill properly.
- Observe all caution plates mounted on the drill.
- Keep foreign objects off table and away from the spindle and bit.
- **BE EXTREMELY CAREFUL** when handling and changing drill bits. Drill bits are sharp. Severe lacerations could result from careless handling procedures.
- If the drill sounds or operates unusually, have it checked by a qualified service person.
- **CUT/CRUSH HAZARD**, keep hand and fingers from under the clamp and spindle while drilling paper. **DO NOT REACH UNDER THE DRILL AREA WHILE OPERATING!**

### 2.2 Power Lockout Procedure

For maximum safety while making adjustments or repairs to your machine, be sure to disconnect power to the machine. Disconnect the power plug from its socket.

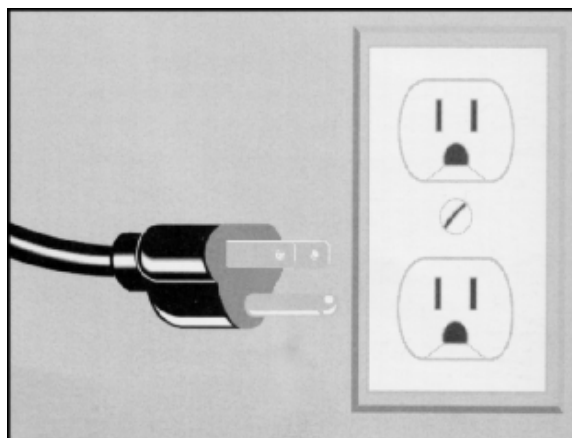

Figure 1 - Main Power Disconnect

## 2.3 Warning Label Definitions

The following warning labels are found at various locations on your machine. Read and understand the meaning of each symbol. If a label is lost from the machine, it should be replaced.



### HAZARDOUS AREA

Disconnect power before cleaning, servicing, or making adjustments not requiring power. Do not alter safety guards or devices; they are for your protection. Replace all guards. Do not operate with any guards removed.

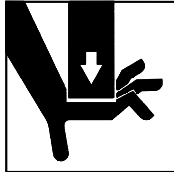

### CUT/CRUSH HAZARD

Keep hands from underneath the knife and clamp.



### SINGLE OPERATOR

Do not operate with more than one person.

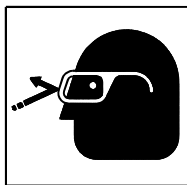

### EYE PROTECTION

Always wear safety glasses while operating drill.

# !OJO!



**CAUTION** This Este simbolo de alerta de seguridad significa ¡ OJO ! - INSTRUCCIONES DE SEGURIDAD PERSONAL. Lea las instrucciones porque se refieren a su seguridad personal. Fall de obedecer las instrucciones que siguen podria resultar en lesiones corporales.

- Esta maquina, junto con sus mecanismos de seguridad, esta disenada para ser manejada por
- **UNA SOLA PERSONA** a la vez. Jamas debe ser manejada por mas de una persona al mismo tiempo.
- La seguridad es la responsabilidad del operario que usa esta maquina.
- **LEA DETENIDAMENTE** el manual de instrucciones y las **PRECAUCIONES DE SEGURIDAD** antes de poner a funcionar la cortadora. Pidale a su supervisor una copia.
- El manejo de la guillotina debe estar exclusivamente a cargo de personal entrenado y autorizado para ello.
- **NO MODIFIQUE LOS MECANISMOS DE SEGURIDAD**, estan ahi para su proteccion no deben ni modificarse ni quitarse.
- **DESCONECTE LA CORRIENTE ELECTRICA** antes de proceder a hacerle servicio de limpieza, engrasar, o de hacer ajustes que no requieren corriente. Trabe el interruptor en la posicion **OFF** (apagado); vea "Procedimiento para cortar la corriente electrica" al pie de esta pagina.
- Eche llave a la guillotina y quite la llave cuando la maquina no esta en operacion; vea "Corriente electrica".
- Asegurese de que la guillotina este debidamente a tierra. Vea "Conexion de la fuerza electrica".
- Verifique el voltaje y asegurese de que este sea suficiente para el debido funcionamiento de la guillotina.
- Preste atencion a todas las placas con advertencias instaladas en esta guillotina.
- No permita que objetos estranos esten en la mesa o cerca de la cuchilla cortadora.
- **TENGA SUMO CUIDADO** al tocar y cambiar la cuchilla. Heridas severas y hasta desmembramiento pueden resultar del manejo sin cuidado o negligente.
- El suelo alrededor de la guillotina debe mantenerse despejado y libre de recortes, desperdicios, aceite y grasa.
- Al haber la necesidad de reemplazar partes hidraulicas, afloje todas las conexiones poco a poco para dejar escapar la presion. Jamas debe aflojarse conexiones mientras la maquina este andando.
- Si la guillotina empezara a sonar o trabajar diferentemente a lo acostumbrado, desconectela y consulte la seccion "Troubleshooting" (Reparador) de este manual. Si no es posible corregir el problema, llame a su servicio autorizado para que le examinen la maquina.
- **PELIGRO DE MACHUQUE** - Mantenga manos y dedos fuera de la agarradera mientras sujeta el papel. Use el calibrador trasero y su rueda de mano para empujar el papel cortado. **NO PONGA SUS MANOS BAJOLA CUCHILLA O AREA DE LA AGARRADERA.**
- **NO OPERE SIN LAS GUARDAS PROTECTORAS!**

## ¡ OJO ! PRECAUCION - Como proceder para desconectar la corriente electrica.

Para maxima seguridad durante ajustes y reparaciones de su maquina, verifique bien que el interruptor principal de control de corriente al cual la maquina esta conectada, este desconectado. El interruptor deba ser puesto en la posicion "OFF" (desconectado) y se debe poner un candado en la anilla. La llave del candado debe ser guardada por la persona que estara efectuando los trabajos de servicio o de reparacion en la guillotina.

Desconecte la corriente electrica antes de proceder a hacer cualquier ajuste o reparacion o de efectuar el engrase en cualquier maquina.

## 3.0 Packing List

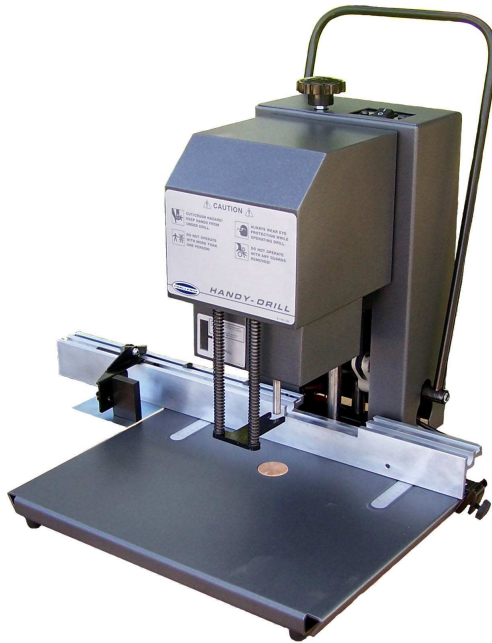

Part No.	Description	Qty.
Handy-Drill	Single Spindle Tabletop Paper Drilling Machine	1
64026	Backgauge Assembly	1
4681	Drill Block	1
F.101-O	Operator's Manual	1
4688	Lubrication Stick (for lubricating drill bits)	1
4687	Drill Drift (for removing drill bits)	1
W-190	1/8 Hex Wrench	1
W-170	9/16 X 1/2 Wrench	1
W-130	3/16 Hex Wrench	1
W-192	3/32 Hex Wrench- Short	1

## Optional Items

Part No.	Description	Qty.
A-4682	Wood Drill Blocks (12 per container)	1
57100	Handy-Sharp Drill Bit Sharpener	1
64052	Spindle for 2" Drill Bits	1
A-4950-1	Handy Chip Remover	1
Replacement Bits	See your Dealer for Original Challenge Bits	

# 4.0 Specifications

---

Description	Inch Units	Metric Units
Drill Head Operation, Hand Lever		
Drill Diameters	13 sizes from 1/8" to 1/2"	3-13mm
Lift Capacity	2-1/2" for drills 1/4" or larger	64mm
Minimum Distance Btw. Holes	3/8" center to center	10mm
Maximum Distance Drill to Side Guide	9-7/8"	25.5cm
Maximum Margin Hole Center to Sheet Edge	2-1/2"	6.4cm
Side Guide Trip	Manual	
<b>Dimensions</b>		
Net Weight	70 lbs	32 kg
Shipping Weight	90 lbs	41 kg
Table Space	18" x 19"	46 x 48cm
Height Overall	22-3/8"	56.8cm
<b>Electrical</b>		
115 Volts, 2.7 Amps, 60Hz, 1 phase, AC. Use 3 Amp Slo-Blo fuse.		

Challenge reserves the right to make changes to any product or specification without notice and without incurring responsibility to existing units.

## 5.0 Installation & Setup

### 5.1 Inspecting Shipment

This machine has been carefully packed to prevent damage during shipment. However, claims for damage or loss are the responsibility of the recipient. Inspect all shipments as soon as they are received. If there is any noticeable damage, note it on the freight bill. Visual and/or hidden damage must be reported to the claims department of the carrier within 15 days. Contact your dealer if you need any assistance. Check the contents of the box against the packing list on page 7. Make sure there are no missing items.

### 5.2 Uncrating

The Handy-Drill weighs approximately 70 lbs (32 kg). DO NOT risk personal injury or damage by attempting to move machinery with makeshift equipment or inadequate help. This machine is shipped enclosed in a corrugated carton. Open the top of the carton and carefully lift machine out and set on to work surface.

### 5.3 Cleaning

After unpacking, wipe down all machine panels and surfaces with a clean cloth as necessary.

### 5.4 Assemble Loose Items

1. Insert the wood drilling block into the hole in the tabletop.
2. Insert the hollow drill bit into the spindle. Push the bit firmly into the spindle. The drill bit is sharp; do not push on the end of the drill bit. Injury may result.
3. The machine was shipped with the drilling depth set above the drilling block. Adjust the drilling depth according to Section 6.2 Set Drilling Depth.

### 5.5 Power Hook-Up

**⚠ CAUTION** **SHOCK HAZARD!** Possible shock could cause personal injury or death. Connect plug to any standard 120 Volt outlet.

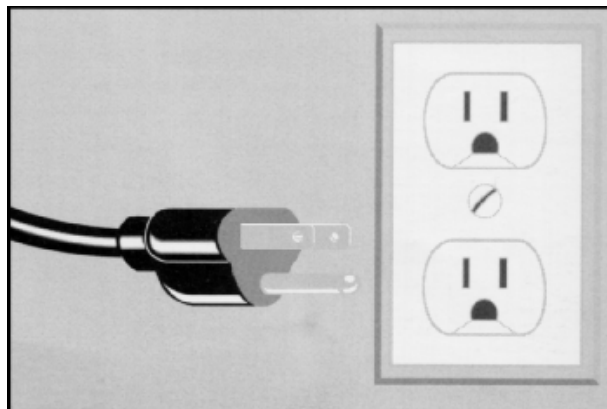

Figure 2 – Main Power Disconnect

# 6.0 Operation

---

**⚠ CAUTION** IMPORTANT: DO NOT ATTEMPT TO OPERATE THE DRILL UNTIL YOU HAVE THOROUGHLY READ AND UNDERSTAND ALL OF THE FOLLOWING INSTRUCTIONS. CALL YOUR AUTHORIZED CHALLENGE DEALER IF YOU STILL HAVE ANY QUESTIONS.

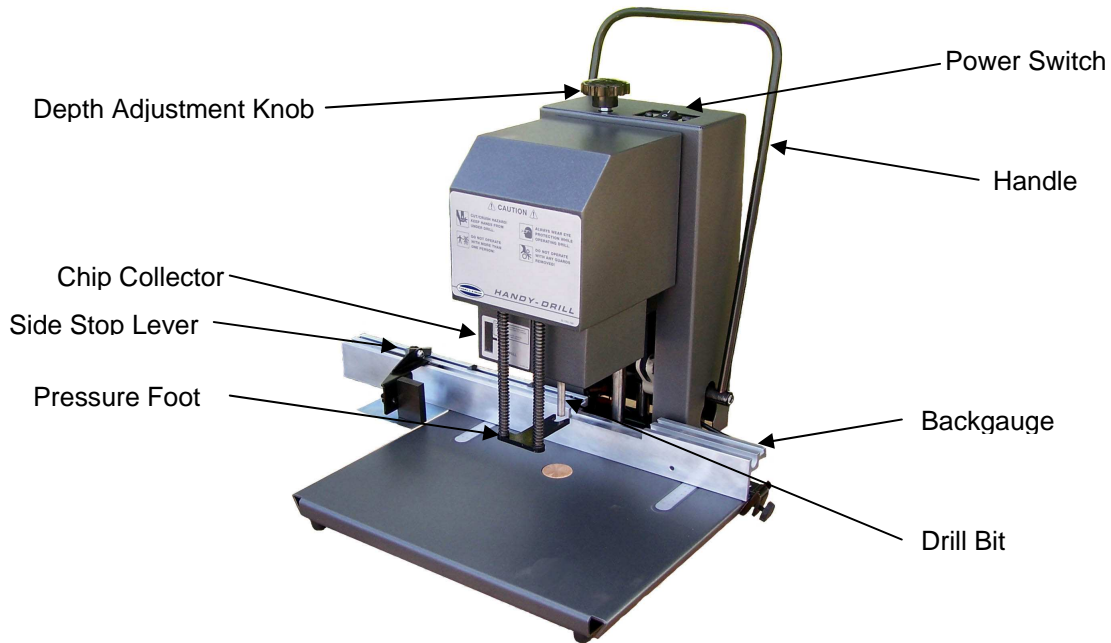

Figure – Machine Controls

## 6.1 Set Hole Spacing

The Handy-Drill backgauge has been set to drill standard three-ring holes, plus one extra stop for four-hole drilling. The stops are held in place with setscrews that run through the top of the stop. Use the 3/32" hex wrench provided in the toolkit in order to loosen the setscrews. Slide the stop to the required dimension as read from the scale on top of the backgauge. Tighten the setscrew until the stop is held firmly in place.

## 6.2 Set Drilling Depth

Turning the adjustment knob on top of the machine sets the depth to which the machine will drill. To drill deeper, turn the knob counter-clockwise. To drill shallower, turn the knob clockwise. The drill depth should be set such that the bottom sheet is cut through without going excessively cutting into the drilling block. Use scrap pieces of paper to set the drill depth.

## 6.3 Drilling

After the machine has been properly installed and adjusted, it is ready for drilling. Set the side stop to the first position and jog stock against the backgauge and side guide. Switch on the machine by pressing the rocker switch to "I". Pull the handle to start the motor and drill. Pull the handle until the stock is drilled through. Raise the handle to its starting position. The motor will automatically shut off.

Lift the side stop lever and slide the side stop to the next position. Continue drilling as described above.

## 6.4 Rotate the Drilling Block

As the drilling block wears, the bottom few sheets may not be cut through. Rotating the drilling block to a new position will correct this. The drilling depth may also need adjustment. After the drilling block has been worn in all the available area on one surface, it may be turned over to use the other surface.

## 6.5 Empty the Paper Chips

The paper chip collectors should be emptied periodically. Check the level of paper chips in the collectors by looking through the sight gauge on the left collector. Switch off the machine before emptying the collectors. To remove the collectors, pull them apart from each other. Reinstall the collectors after emptying. Two safety switches prevent the motor from operating with the chip collectors removed. Switch on the machine when ready for use.

## 6.6 Drilling with 2 Inch Long Bits

Not all diameters are available in 2-1/2 inch drill lengths. More diameters are available in 2-inch long drills. The Handy-Drill can drill with 2-inch drills by setting the machine up more permanently for 2-inch drilling.

Follow these instructions to setup the machine to drill a 2-inch depth on a more permanent basis:

1. Switch off and disconnect power to the machine.
2. Remove the two chip collectors.
3. Remove the hollow drill.
4. Use the 1/8" hex wrench to remove the two setscrews from the spindle. **Caution! Loosening the second setscrew will allow the spindle to fall to the tabletop.** Hold the spindle while removing the setscrews.
5. Remove the spindle from the machine.
6. Screw the setscrews into the optional spindle **64052**.
7. Slide the spindle all of the way onto the motor shaft until it is stopped by the shoulder on the shaft.
8. Tight the setscrews onto the flat surface on the shaft.
9. Reinstall the chip collectors.
10. A 2" long drill bit may now be used.

# 7.0 Troubleshooting

---

<b>Problem</b>	<b>Area to Check</b>	<b>Solution</b>
1. Motor won't start	Check power cord Check circuit breaker Check power switch Check chip collector safety switches	Plug in power cord Reset circuit breaker Switch on main power Readjust or replace defective switches. Install chip collectors.
2. Drill head won't return	Check for bind in lever assembly  Check lift spring – may be broken or stuck	Free bind, clean and oil  Pry up head, clean and oil shaft (Replace spring if necessary)
3. Drill head will not come down	Check for bind in guide shafts	Free bind, clean and oil shafts
4. Difficult to push bit through stock	Dull drill bit	Sharpen or replace with new
5. Bottom sheets not being drilled	Worn drilling block or depth misadjusted	Turn drilling block and/or adjust drilling depth knob

---

## 8.0 Drilling Tips

---

**Important!** To prevent the drill from overheating, always avoid drilling too slowly. The drill should be brought down as rapidly as possible allowing the drills to easily cut through the paper.

**Plastic Bindings** - Drilling holes for plastic bindings, instead of punching them, is practical and saves a great deal of time, particularly on long run jobs.

**Keep Drills Sharp** - A dull drill is the major cause of drill breakage and production tie-ups. Usually after three hours of drilling, depending on the type of paper being processed, the drill should be sharpened. A dull drill results in poor quality work.

**Keep Drills Clean** - A dirty and rusty drill will not permit the free upward passage of the drill chips. Pressure built up by a clogged drill will split or break the drill. To keep it free from dirt or rust, clean the drill of all chips after each use and apply light oil to the inside and outside. Drills should be cleaned out immediately after each use. This is particularly true if a coated or varnished stock has been drilled. On these jobs the coating on the chips frequently fuse the chips into one solid mass when the drill cools, causing breakage the next time the drill is used.

**Lubricate Drills** - Lubrication assists in the passage of the chips and helps avoid overheating of the drills. Use readily available stick lubricants for this purpose. Hold the end of the stick against the side of the rotating drill. Be sure to touch the cutting edge with the lubricant also. Wipe off excess oil before drilling. **CARE MUST ALWAYS BE TAKEN WHEN HANDLING DRILLS.**

**Keep Spindle Clean** - Clean out the drill spindle frequently. This will prevent any buildup in the spindle of the drill.

**Set the Drills Correctly** - Do not cut too deeply into the cutting block. The drill should just touch the block and cleanly cut through the bottom sheet. During drilling, do not set the drill deeper into the block but change the position of the block frequently. Drilling deeper into the block dulls the drills quickly. Use a piece of chipboard underneath your stock. This will make handling the stock easier and will ensure that the last sheet is cut cleanly through.

**Check for Drill Wobble** - If the spindle is badly worn or bent through maladjustment, have it replaced immediately. A wobbly or loosely held drill will break.

**Check Your Drill Sharpener** - The cutting edge of the sharpening bit should be inspected frequently to make certain that it is sharp and free of nicks. Never let a drill drop onto the sharpening bit. It will chip the sharpening edge. Use gentle pressure when sharpening - let the sharpening bit do the work. Check the sharpness of the drill after sharpening. The cutting edge should be razor sharp.

Just a little time and effort taken with each use of your paper-drilling machine should result in trouble free operation over many years.

**Parts Customers:** The Challenge Machinery Company provides parts with the express understanding that they are to replace parts found missing or no longer serviceable on equipment designed and/or manufactured by Challenge. The Challenge Machinery Company assumes no liability for any modification or alteration to any Challenge products, and The Challenge Machinery Company does not authorize any such modification or alteration to any Challenge products. Any modification or alteration of any Challenge product will void any remaining warranty.

# 9.0 Footprint

---

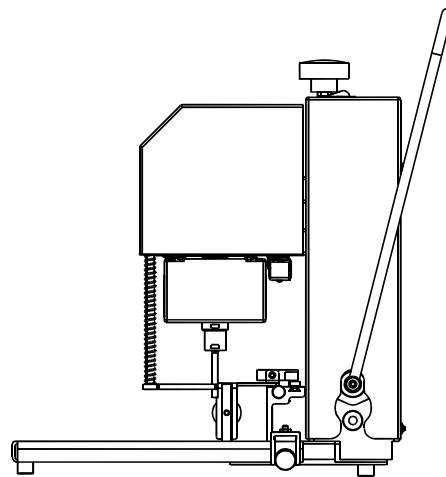
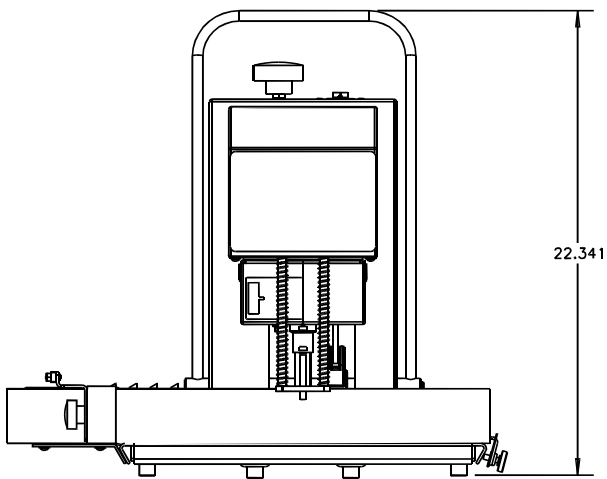
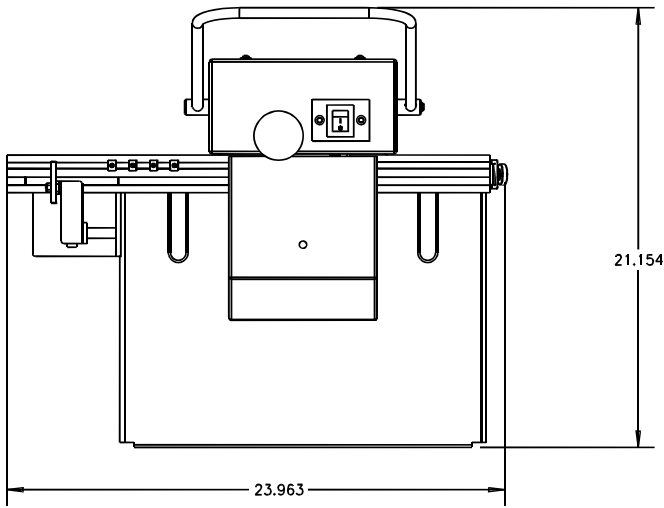

# NOTES

# 10.0 Safety Systems Test

---

Machine manufacturer CHALLENGE

Model HANDY-DRILL

Serial Number \_\_\_\_\_

Frequency of test: **THESE TESTS SHOULD BE PERFORMED AT THE BEGINNING OF EACH WORK DAY.**

1. Switch on the machine.
2. Remove one of the chip collectors.
3. Pull the head down using the pull-down lever. The motor should NOT switch on. If the motor switches on, switch off the machine, disconnect main power, and call for service.
4. Reinstall the chip collector and remove the other one.
5. Pull the head down using the pull-down lever. The motor should NOT switch on. If the motor switches on, switch off the machine, disconnect main power, and call for service.
6. Reinstall the chip collectors.

Please enter date and initials for the test.

Date \_\_\_\_\_  
\_\_\_\_\_

Date \_\_\_\_\_  
\_\_\_\_\_

Date \_\_\_\_\_  
\_\_\_\_\_

Date \_\_\_\_\_  
\_\_\_\_\_

Date \_\_\_\_\_  
\_\_\_\_\_

Repairs	Initials of Repairer	Date
_____	_____	_____
_____	_____	_____
_____	_____	_____
_____	_____	_____
_____	_____	_____
_____	_____	_____
_____	_____	_____
_____	_____	_____
_____	_____	_____
_____	_____	_____
_____	_____	_____
_____	_____	_____
_____	_____	_____
_____	_____	_____
_____	_____	_____